

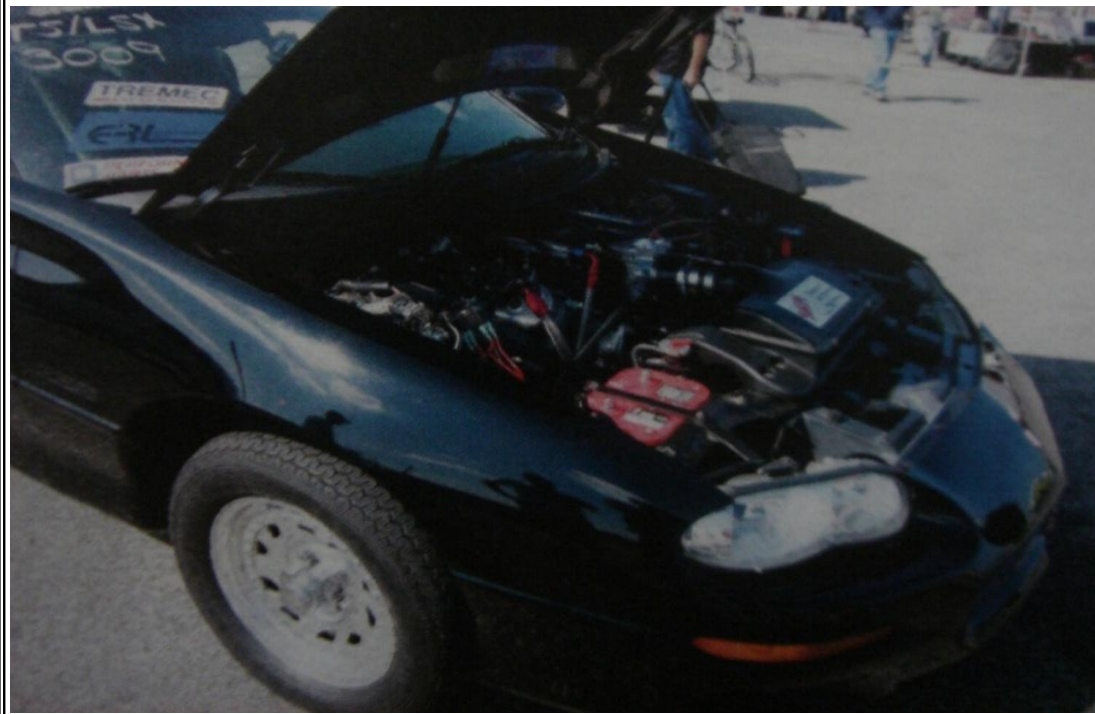

Republic of the Philippines
DEPARTMENT OF EDUCATION



K to 12 Basic Education Curriculum Technology and Livelihood Education Learning Module



AUTOMOTIVE SERVICING

EXPLORATORY COURSE

Grade 7 and Grade 8

TABLE OF CONTENTS

	Page
What Is This Module About?	3
How Do You Use This Module	4
LESSON 1 – Use Hand tools	5-51
LESSON 2 – Perform Mensuration and Calculations	52-78
LESSON 3 – Interpret Plans and Drawings	79-139
LESSON 4 – Perform Shop Maintenance	140-176
LESSON 5 – Practice Occupational Health and Safety Procedures	177-231
Answer Keys	232-243
Acknowledgment	244



What Is This Module About?

Welcome to the course of **Automotive!**

This Module is an exploratory and introductory course which leads you to **Automotive Servicing** National Certificate Level I (NC I)¹. It covers **5** common competencies that a Grade 7/Grade 8 Technology and Livelihood Education (TLE) student like you ought to possess, namely:

- 1). Use Hand Tools
- 2). Perform Mensuration and Calculations
- 3). Interpret Plans and Drawings
- 4). Perform Shop Maintenance
- 5). Practice Occupational Health and Safety Procedure

These **5** common competencies are covered separately in 5 Lessons. As shown below, each Lesson is directed to the attainment of one or more learning outcomes:

Lesson 1 – Use Hand Tools

- LO 1 - Plan and prepare for tasks to be undertaken.
- LO 2 - Prepare and use hand tools.
- LO 3 - Prepare report of malfunctioning tools.
- LO 4 - Maintain hand tools.

Lesson 2 – Perform Mensuration and Calculations

- LO 1-Select measuring instrument and carry out measurement and calculations.
- LO 2 - Maintain measuring instruments.

Lesson 3 – Interpret Plans and Drawings

- LO 1 - Analyze signs, symbols and data.
- LO 2 - Interpret technical drawings and plans.

Lesson 4 – Perform Shop Maintenance

- LO 1 - Inspect and clean tools and shop equipment.
- LO 2 - Store and Arrange tools and shop equipment.
- LO 3 - Dispose waste/ used lubricants.

Lesson 5 – Practice Occupational Health and Safety Procedures

- LO 1 - Identify hazards and risks.
- LO 2 - Evaluate hazards and risks.
- LO 3 - Maintain occupational health and safety awareness.

Your success in this exploratory course on **Automotive** is shown in your ability to perform the performance standards found in each lesson.

¹NATIONAL CERTIFICATE (NC) is a certification issued to individuals who achieved all the required units of competency for a national qualification as defined under the Training Regulations. NCs are aligned to specific levels within the PTQF. (TESDA Board Resolution No. 2004-13, Training Regulations Framework)

NATIONAL CERTIFICATE LEVEL refers to the four (4) qualification levels defined in the Philippine TVET Qualifications Framework (PTQF) Where the worker in:

a. NC I performs a routine and predictable tasks; has little judgment; and, works under supervision;

b. NC II performs prescribe range of functions involving known routines and procedures; has limited choice and complexity of functions, and has little accountability;



How Do You Use This Module?

This Module has five Lessons. Each Lesson has the following parts:

- Learning Outcomes
- Performance Standards
- Materials/Resources
- Definition of Terms
- What Do You Already Know?
- What Do You Need to Know?
- How Much Have You Learned?
- How Do You Apply What You Have Learned?
- How Well Did You Perform?
- References

To get the most from this Module, you need to do the following:

1. Begin by reading and understanding the Learning Outcome/s and Performance Standards. These will tell you what you should know and be able to do at the end of this Module.
2. Find out what you already know by taking the Pretest then check your answer against the Answer Key. If you get 99 to 100% of the items correctly, you may proceed to the next Lesson. This means that you need not go through the Lesson because you already know what it is about. If you fail to get 99 to 100% correctly, go through the Lesson again and review especially those items which you failed to get.
3. Do the required Learning Activities. They begin with one or more Information Sheets. An Information Sheet contains important notes or basic information that you need to know.
After reading the Information Sheet, test yourself on how much you have learned by means of the Self-check. Refer to the Answer Key for correction. Do not hesitate to go back to the Information Sheet when you do not get all test items correctly. This will ensure your mastery of basic information.
4. Demonstrate what you learned by doing what the Activity / Operation / Job Sheet directs you to do.
5. You must be able to apply what you have learned in another activity or in a real life situation.
6. Accomplish the Scoring Rubrics for you to know how well you performed.

Each Lesson also provides you with references and definition of key terms for your guide. They can be of great help. Use them fully.



If you have questions, ask your teacher for assistance.

LESSON 1

Use Hand Tools



LEARNING OUTCOMES:

At the end of this Lesson, you are expected to do the following:

- LO 1 prepare hand tools;
- LO 2 use appropriate hand tools and test equipment;
- LO 3 prepare record of malfunctioning tools; and
- LO 4 maintain hand tools.



Definition of Terms

Adjusting - an activity or task done to arrange parts in relation to position or regulate a clearance in relation to accuracy

Air cleaner - a paper or cellulose element that filters the air before entering the engine

Assembling - an activity or task of putting together of parts or mechanism in correct and complete position

Bolt - a round rod metal with external threads. The external thread can be screwed in an internally threaded stock or nut. It usually has square or hexagonal head where a wrench can be inserted to loosen and tighten

Checking - a process of verifying and confirming the condition of parts by observation or inspection

Fault - a condition of flaw or imperfection

Hand tools - a portable devices that are guided and operated by hands

Hose - a flexible and heat resistant rubber that serves as a passage of coolant in the cooling system

Inspection - examining or looking closely as a course of action

Loosen - release from tightness or free from restraint

Major task - a work which is reasonably great in scope

Malfunction - a condition where a part or system does not function normally

Measuring - an activity or task of getting the amount, size or quantity of a certain thing or stock/parts

Nuts - a usually square or hexagonal shape block of metal with internal threaded hole where an externally threaded bolt can be screwed

Overhauling - a process of examining and repairing of condition if necessary

Principle - a fundamental truth or law as the basis of reasoning or action

Repairing - restoring a faulty condition after damage or wear

Safety - freedom from danger or risk

Standard procedure - an established, prescribed way of doing a task or series of action

Technique - a method of skillful manipulation of activity for efficient and time saving task

Testing - a process of determining the working condition of a system or mechanism

Tighten - to give additional twisting force to make it tighter

Tune-up - an orderly process of inspection, diagnosis, testing, and adjustment that is periodically necessary to maintain peak engine performance

Underchassis- the underparts of a vehicle. It is composed of different systems such as the power trains, steering, suspension, wheels, and tires. It aids the vehicle in performing its duties

LEARNING OUTCOME 1

Plan and prepare for tasks to be undertaken

PERFORMANCE STANDARDS

- Tasks to be undertaken are properly identified.
- Appropriate hand tools are identified.
- Hand tools are selected according to the task requirement.



Materials/Resources

1. Table
2. Pencils
3. Rugs
4. Screw driver
5. Fire extinguisher
6. Steel rule
7. Drill bit



What Do You Already Know?

Let us determine how much you already know about planning and preparing for task to be undertaken. Take this test.

Pretest LO 1

Directions: Answer the question by writing the letter of the best answer on a separate sheet of paper.

1. A successful task can be achieved through _____ planning and preparation.
A. careful and proper
B. courageous
C. constant
D. seldom
2. Good preparation will boost your _____.
A. confidence
B. skill
C. intelligence
D. weakness
3. One of the factors to consider when planning and preparing for the task in order to avoid accident is _____.
A. materials
B. safety
C. place
D. waste disposal
4. When the task calls for the removal of parts, use _____.
A. cleaning tools
B. marking tools
C. loosening and tightening tools
D. measuring tools
5. Measuring is a task that needs _____.
A. cleaning tools
B. measuring tools
C. cutting tools
D. tightening and loosening tools



What Do You Need To Know?

Read Information Sheet 1.1 very well; then, find out how much you can remember and how much you have learned by doing Self-check.

Information Sheet 1.1

Plan and prepare for the tasks to be undertaken

Planning is part and parcel of achieving a successful task. Your ability to plan will enable you to attain your purpose. Many successful automotive entrepreneurs have realized their success through proper and careful planning. Likewise, aside from planning, you should also give importance to preparation. Good preparation will boost your confidence because it means that you are ready to do the task because you have sufficient knowledge about it. The following are some factors to be considered when you plan and prepare for the tasks:

1. **PLACE.** See to it that the place for doing the task is conducive to work, well-ventilated, clean, and has good lighting. A space provided for freedom to move is important. A place chosen will give you idea on what task is to be done.



2. **MATERIALS.** Be sure that aside from tools and equipment, necessary materials and fixtures to be used such as bench work and manual of specifications must be available and ready for use.

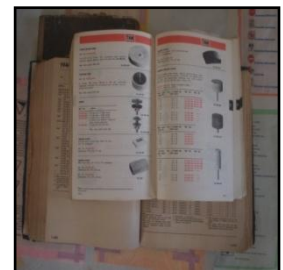

3. **WASTE DISPOSAL.** Used parts or compound substance such as oil, grease and used chemical bottles must be disposed in proper storage bin or container. Non-disposal of used chemical substance invites hazard to environment and poses danger to health.



4. **TOOLS/EQUIPMENT.** Tools and equipment must match with the task to be done. You should be careful enough to choose tools and equipment that are worthy of use. They must be in good condition so that it can be easily utilized without damaging the parts.



5. **SAFETY.** Always prioritize safety. Remember that accident is not an excusable incident. It can be avoided. Always remember the motto “Safety first”.



6. **SERVICE PROCEDURE/TASK.** Identify what task to perform before identifying materials and tools to use. The service procedure/task to employ will tell you the corresponding tools and materials needed. Appropriate tools to use with the task will enhance your ability to provide a competitive and efficient service.



Removing

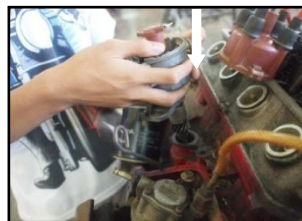

Installing

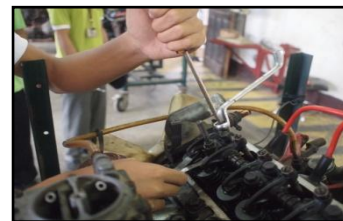

Adjusting



Cleaning



Measuring



Repairing

The following service procedure/tasks will help you identify and select tools required when performing a job.





SERVICE PROCEDURE/ TASKS	TOOLS NEEDED
<ul style="list-style-type: none"> • Adjusting • Checking • Inspecting • Measuring 	Cutting tools Loosening and tightening tools Measuring tools
<ul style="list-style-type: none"> • Assembling • Installing 	Loosening and tightening tools Marking tools Measuring tools
<ul style="list-style-type: none"> • Cleaning 	Cleaning tools
<ul style="list-style-type: none"> • Disassembling • Removing 	Cleaning tools Loosening and tightening tools Marking tools
<ul style="list-style-type: none"> • Reconditioning • Repairing 	Cleaning tools Loosening and tightening tools Marking tools Measuring tools
<ul style="list-style-type: none"> • Testing 	Loosening and tightening tools Measuring tools



How Much Have You Learned?

Self-Check 1.1

Directions. Match the pictures in Column A with the corresponding tasks in column B and the tools to be used in Column C. Write your best answer on the space provided.

Column A	Column B	Column C
1.  B. ____ C. ____	a. measuring	▲ loosening and tightening tools
2.  B. ____ C. ____	b. assembling	▶ measuring tools
3.  B. ____ C. ____	c. cutting	▼ cleaning tools
4.  B. ____ C. ____	d. removing	◀ cutting tools
5.  B. ____ C. ____	e. cleaning	◆ holding tools

Refer to the Answer Key. What is your score?



How Do You Apply What You Have Learned?

Directions: Given are the following factors to consider when planning and preparing for the task to be undertaken. Make a plan on how tasks are prepared by placing the following factors in the chart.

A. Factors to consider:

1. Place – lighting, ventilation, space of work
2. Materials – fixtures, bench work, manual of specifications
3. Waste disposal – trash bin
4. Tools and equipment – cabinet, tools shelf
5. Safety – Emergency kit, fire extinguishers, safety signs and symbols

SERVICE SHOP

B. Demonstrate one of the service procedures/tasks

Service Procedure/Tasks	
1.	_____
2.	_____
3.	_____
4.	_____
5.	_____
6.	_____
7.	_____

LEARNING OUTCOME 2

Prepare and use hand tools

PERFORMANCE STANDARDS

- Appropriate hand tools are checked for proper operation and safety.
- Unsafe or faulty tools are identified.
- All tools are marked for repair according to standard company procedures.



Materials

- Brush
- Scraper
- Wiping cloth
- Chisel
- Hacksaw
- Electric drills
- Hole saw
- Machinist
- Pliers
- Side cutting pliers
- Tin snip
- Hammers
- Ball peen
- Brass/Plastic
- Starting
- Drift punch
- Pliers – Combination
- Crimping
- Splicer
- Cutting
- Long nose
- Vise-grip
- Bench vise
- Wrenches – Allen
- Box
- Combination pliers
- Side cutting pliers
- Open
- Socket
- Spark plug
- Torque wrench
- Screwdrivers
- Allen
- Flat
- Offset
- Phillips
- Stubby
- Center punch
- Scriber
- Caliper
- Metal tape measure
- Steel rule
- Torque wrench
- Utility rug
- Multi tester
- Vanier caliper



What Do You Already Know?

**Determine how much you already know about preparing and using hand tools.
Take this test.**

Pretest LO 2

Direction: Answer each question by writing the letter of the best answer.

1. When you want to make things done with less effort and efficiency, use _____.
A. bench work
B. space
C. lights
D. tools
2. Possessing basic knowledge will help you _____ tools for the tasks.
A. guess
B. presume
C. identify and select
D. replace
3. Choosing the right tool is easy but requires a lot of _____.
A. assumption
B. practice
C. deduction
D. presumption
4. Using incorrect tools for the job will result in _____.
A. efficiency
B. good performance
C. injury
D. good values
5. Basic level of competency involves _____.
A. checking and inspection
B. overhauling
C. disassembling
D. major job



What Do You Need To Know?

Read Information Sheet 2.1 very well. Then find out how much you can remember and how much you learned by doing Self-check.

Information Sheet 2.1

Prepare hand tools

When doing any kind of work, tools are needed to have things done. When fixing furniture, repairing home appliances, or doing simple repair, tools help you make work easy, with less effort but with efficient result. Without the needed tools, much time is consumed and more effort is required to accomplish your task.

In order for you to accomplish a task efficiently, you must possess basic knowledge on how to identify and select tools that are usable, of good quality and free from faults. The task required calls for the right kind of tools to prepare. Simple jobs usually need simple tools to use. Heavy jobs need the use of heavy tools. Through constant practice, and simple observation, you become skillful in selecting the right tool for the job.

In automotive application, it is important that the needed tools are not defective and must be perfect for the job to finish on time. The use of faulty tools might result in injury and damage to you and the parts you are working on.

Preparing hand tools to use is easy but requires a lot of practice. Depending on the level of work to be done, whether it is basic level which involves inspection and checking, cleaning and simple fixing of parts; the common level for replacing of basic parts such as air cleaner, fuel filter, hoses; and the core level when performing major tasks such as tune-up, overhauling and underchassis work.

The extent of work will give you information to identify and select the size, shape and type of tools needed to accomplish the task.

The following tools for the specific task have corresponding name of specific tools in performing the task.

TOOLS FOR A SPECIFIC PROCEDURE/TASK	NAME OF SPECIFIC TOOLS
• Cleaning tools	Brushes (fiber and wire), Scraper, Wiping cloth
• Cutting Tools	Chisel, File, Hacksaw, Electric drills, Hole saw, Machinist pliers, Side cutting pliers, Tin snip
• Driving tools	Hammers - Ball peen, Brass/Plastic, Starting and Drift punch

<ul style="list-style-type: none"> • Bending /Holding/ Twisting/ Crimping Tools/Gadget 	Pliers – Combination, Crimping and Splicer, Cutting, Long nose, Vise-grip, Bench vise
<ul style="list-style-type: none"> • Loosening and tightening tools 	Wrenches - Allen, Box, Combination, Open, Socket, Spark plug, Torque wrench Screwdrivers – Allen, Flat, Offset, Phillips, Stubby,
<ul style="list-style-type: none"> • Marking tools 	Center punch, Scriber
<ul style="list-style-type: none"> • Measuring tools 	Caliper, Metal tape measure, Steel rule, Torque wrench

Operation of hand tools

To gain more knowledge about the tools, you must know its basic functions so that you will be able to identify its use.

I. CLEANING TOOLS

1. **Scraper** is a flat thin sheet of metal with wooden or plastic handle. It is used to scrape hard to remove dirt or stubborn grime or plastic sticker.
2. **Steel/Wire brush** are thin strips of metal inserted in a wooden or plastic stock. It is used to remove rust, hard to remove dirt and grime with sweeping action.
3. **Utility rag** is a fibrous cloth used in cleaning and wiping dirt and dust.



II. BENDING/HOLDING/TWISTING/CRIMPING TOOLS

1. **Pliers** are generally used as all-around tools. They have the capability for bending, crimping, cutting, holding, stripping and twisting. They are available in various shapes and sizes. Generally, pliers used for electrical job are insulated, whereas those for mechanical work are not insulated but sometimes equipped with rubber for gripping. Pliers are not used as substitute for wrenches.

Side cutting pliers are tools having a broad, flat, and rough jaw. They have a pair of nipper-like blades used for cutting and bending wires. **Combination pliers** are equipped with adjustable opening by means of a slip joint. It is used for gripping object because of its inner notch and also used for cutting and bending small wires. **Long-nose pliers** have a needle-nose ends used for holding or picking small object. They have a razor-like blade on its jaw for stripping, cutting and bending wires. **Stripping and crimping pliers** have two-half round edges used to strip electrical wire and a crimping nose to fold and lock wire connector. **Vise grip or locking jaw pliers** are specially-designed pliers used for holding work pieces together. They have a variety of uses such

as inserting a fastener, holding bolts while tightening or loosening the nut and removing rounded head bolts and nuts. **Machinist pliers** have adjustable and cutting jaws with tooth-edged nose used for holding, bending and cutting wires.

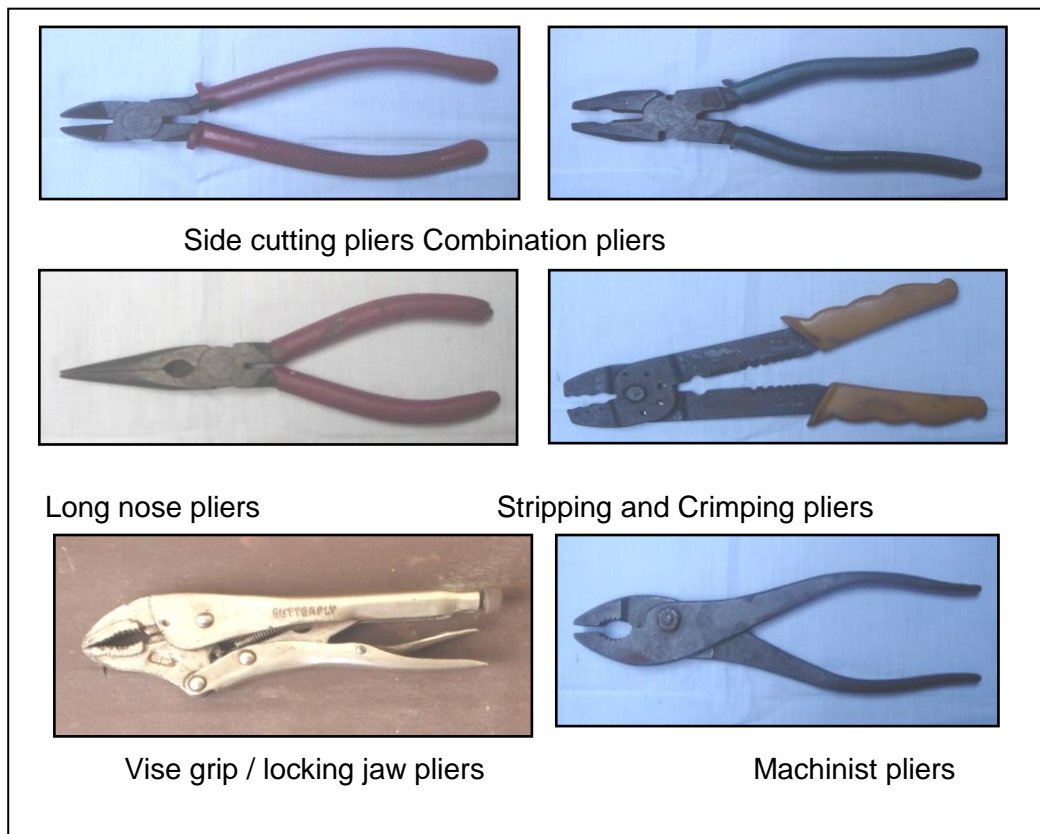

2. **Bench vise** is a device for holding and bending pieces of metal. It consists of one fixed and one movable jaw operated by a clamping action of the screw.



III. CUTTING TOOLS

1. **Chisel** is a hand tool essentially used for cutting bolts, nuts and rivets. It comes in different types and sizes. A **flat** cold chisel is used for general cutting. Special chisels like a **diamond point** are used for cutting sharp-bottomed groove and a round-end chisel for cutting oil grooves.

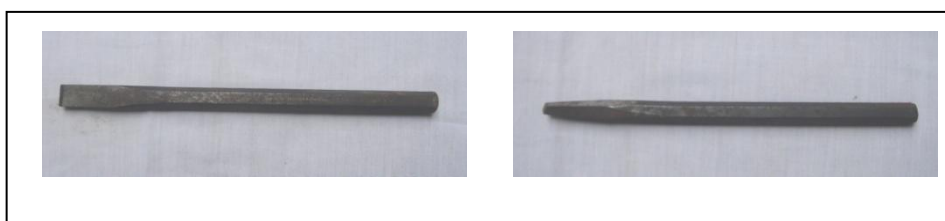

2. **Electric Drill** is a tool for boring holes. It is made of either carbon steel which requires frequent sharpening or high speed steel which requires less sharpening. Electric drill is designed for slow and high speed drilling. It can be **hand operated** for slow drilling or **electrically operated** portable or heavy duty machine for high speed drilling with replaceable drill attachment at the end. Drills come in various diameter sizes. Electric drill can also be used as a portable grinding machine by attaching a handy grinder on its end.



3. **File** is a hard steel tool used for smoothing metal. It comes in various shapes such as flat, round, half-round, and triangular. It also comes in different fine-to-coarse cutting edges. A **single-cut** file has a single series of cutting edges parallel to each other whereas a **double-cut** file has two sets of cutting edges that cross at an angle.



4. **Hacksaw** is an excellent tool for cutting bolts, tubing and light to fairly thick metal. It has a light frame handle with blade connected to both ends of the frame. Depending on the type of work to be cut, a hacksaw blade tooth per inch (TPI) determines the extent of metal to be cut. It comes in 14, 18, 24, 32 teeth per inch. The lower the number, the lesser the number of TPI and the greater its cutting ability. A special hacksaw such as **hole saw** is used when boring thin and large diameter sheet of metal. It is electrically operated by an electric drill

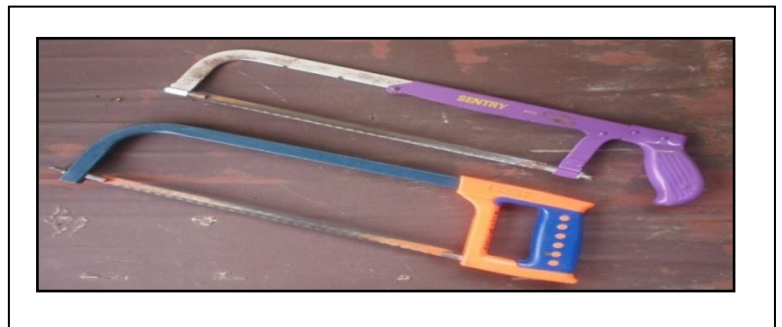

5. **Tin Snip** is a scissor-shaped tool used for cutting thin sheets of metal.



IV. DRIVING TOOLS

1. **Hammers** are generally used for driving or striking work. It comes in various sizes, weights, and kinds. **Ball peen** hammer is basically used by machinists as in automotive applications. It has a weighty ball-shaped metal at the end of the handle with flat surface on one side for striking a chisel or appropriate work and a rounded shaped for riveting or penning. The **brass or plastic-tipped** hammers are used for striking soft and delicate part such as aluminum or plastic to avoid danger of breaking or marring the surface.



2. **Puncher** is a tool made of steel. It is used to cut or drive out a bolt or lock needle pin out of a hole. **Starting punch** is a punch with tapered portion used for initially starting a pin or rivet removal. After initially starting the pin, the **drift punch** or **pin punch** is used to complete the job of removing the pin. A **hole punch** is used in cutting a paper gasket in making holes.

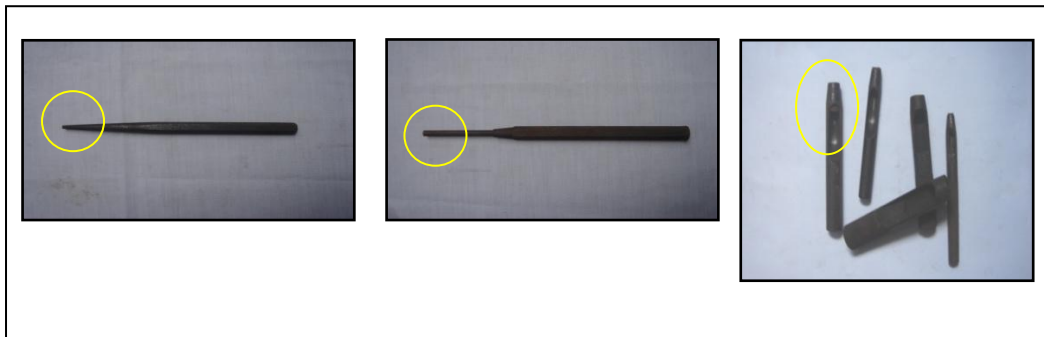

V. LOOSENING AND TIGHTENING TOOLS

1. **Wrenches** are tools for loosening and tightening of bolts and nuts. It comes in different forms and number in Metric or in English sizes.

1.1 Allen wrench is used in a type of screw bolt with a hexagonal hole on the head.

1.2 Box end wrench is an enclosed end tool used for moderate application for loosening and tightening bolts and nuts.

1.3 Combination wrench is a tool with an open-end on one side and box-end on the opposite side. It has the same size on both ends and used in loosening and tightening bolts and nuts.

1.4 Oil filter wrench is a circular-shaped steel with internal tooth and handle. It is inserted to the oil filter body, tightened as it is turned for removal.

1.5 Open end wrench is a tool with open end used for light application in loosening and tightening bolts and nuts.

1.6 Socket wrench is a tubular-like tool with an enclosed end used for heavy application for loosening and tightening bolts and nuts.

1.7 Spark plug wrench is a socket-like wrench intended for removing and installing spark plugs.

1.8 Tire wrench is a cross-like or sometimes L-shaped piece of round bar used to remove the wheels of the vehicle.

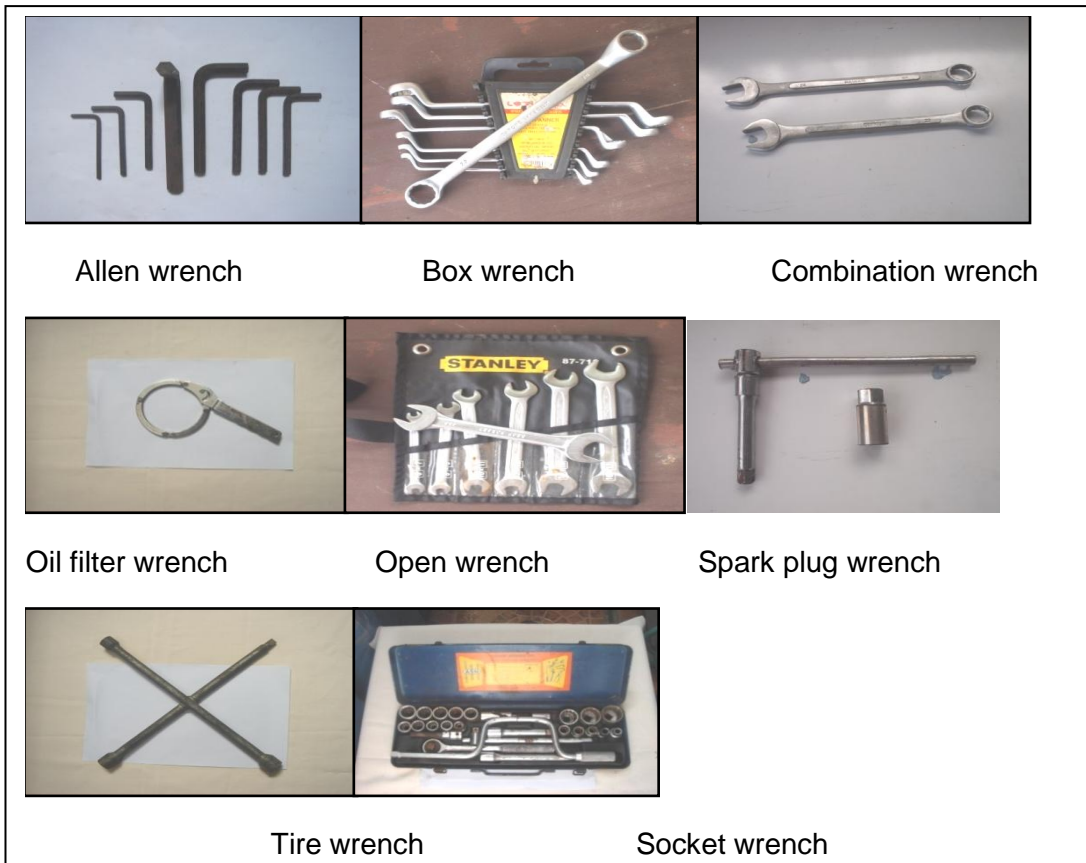

2. **Screwdriver** is a piece of long metal rod made of hardened steel and tempered at the tip. It is used to loosen and tighten screws. It usually comes in different sizes and forms of tips. An **Allen screwdriver** has hexagonal sides at the tip and used for hexagonal slot head of the screws. A **flat screw driver** has flat tip at the end and used in a single groove screws. A **Philips screw driver** has cross-like tip at the end and used in a cross groove head of the screws. Depending on the kind of application used, a screwdriver can be of special types such as **stubby screwdriver** that has a short shank and handle. It is used for tight space where a typical screwdriver cannot be used. An **offset screwdriver** has a shank bent in opposite direction several distance just before the end of the tip. It is used to loosen and tightened screws in difficult areas

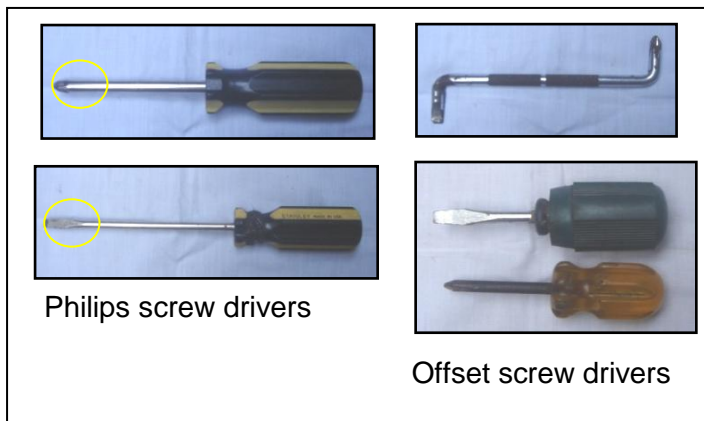

VI. MARKING TOOLS

1. **Center punch** is a tool made of hardened steel with conical tip point on its end. It is about 3 to 4 in. long in length and used for marking the material before drilling. It is also used for marking two parts so that after removing, it can be easily replaced by aligning the marks together.

2. **Scriber** is a thin steel rod with pointed tip on its end. It is used for marking fine lines on metal for layout work.
3. **Pencil** is a thin strip of graphite enclosed in a wooden case and used for making drawings and marking lines.



Center punch



Scriber



Pencil

VII. MEASURING TOOLS

1. **Torque wrench** is a special service tool for measuring the twisting force applied when tightening bolts and nuts.
2. **Steel rule** is a measuring strip of steel available in various lengths in metric and English system. It is available in 12, 24, 36 and 48 inches size. It is used in linear measurement of short length or height.
3. **Caliper** is a tool used in measuring the diameter of a circular work. The Inside caliper is used in measuring the inside diameter whereas the outside caliper is used in measuring the outside diameter of an object. The caliper is adjustable. The Vernier caliper is a good example that is capable to measure both the inside and outside diameter of an object with accuracy. It can also measure the thickness and thinness in thousandths of an inch.
4. **Metal tape measure** is a push and pull, long strip of thin sheet of metal with corresponding increments in millimeter and inches graduation. It is used for measuring stock and can be bought in different sizes of length.
5. **Feeler gauge** is a thin strip of metal with different thickness used to measure or set gap and clearance between parts of mechanism.



Torque wrench



Steel rule

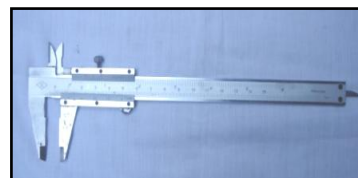

Vernier Caliper



Steel tape measure



Feeler gauge

Common faults of hand tools

A hand tool is the best friend of every serviceman. With it, work becomes easy and efficient. But, if tools are not given careful attention they will easily give up without maximizing its usefulness. If this condition continues, it will result in a faulty condition. This faulty condition results from ineffective use which eventually might create the risk of danger and accident.

Common faults of hand tools are usually blamed on **manufacturer's defect**. However, it doesn't mean that whenever hand tools become faulty or defective, the manufacturer always carries the responsibility.

Metal fatigue is one of the usual causes of faulty hand tools specially those that are made from steel. Like human body that sometimes needs rest, metal fatigue is developed from **overuse of tools**. It can also result from **too much imposition of force** on tools which is less than its capacity to endure. It will render the tools unserviceable.

Because of **wrong habits or attitudes, human error** also contributes to faulty hand tools. **Wrong use of tools** for the job will create bad effect on the tools. A screwdriver which is intended for loosening and tightening screws becomes defective and reduces its usefulness when used like cold chisel.

Natural tear and wear causes tools to widen or reduce its size. A slack is noticeable when a box wrench for removing the bolt becomes loose when the internal sides of the wrench is bigger than the external sides of the bolt's head. If used in this condition, both the bolt and the wrench will develop fault.

Tools not kept, not maintained, and unused will become rusty. Tools with jaws become difficult to operate. It will take time cleaning and removing the corrosion before it becomes functional.

To become more aware of the condition of hand tools, it is good to know some of its specific faults.

1. **Cleaning tools.** Wire and fiber brush must be tightly fit and securely intact on its recess. *Frayed brushes* indicate overuse. Bristles can easily be removed and may splatter. They can pose danger to the eyes and skin. Likewise, *dirty rags* can create dust and affect the respiratory system.

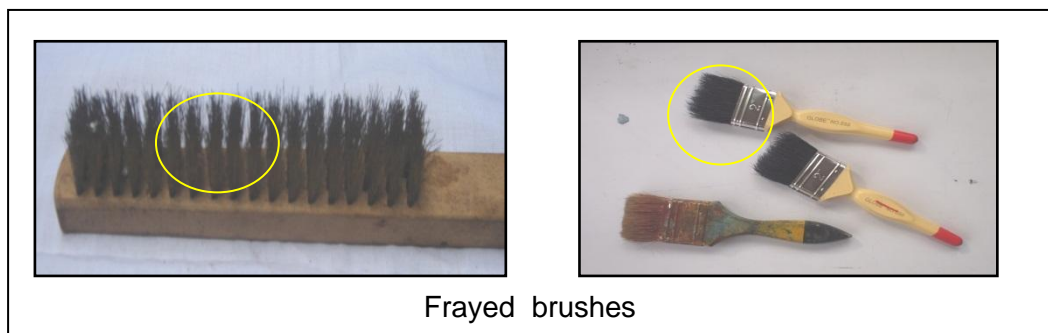

Frayed brushes

2. **Bending/ Cutting/ Holding/Twisting tools.** *Overused, dulled teeth* cutting edge of tools such as hacksaw, tin snip and cutter pliers will reduce time and work performance. *Loose hacksaw blade to frame* must be repaired or replaced at once. *Dulled teeth and loose pivot lever* of holding tools such as machinist and combination pliers lessen the grip and reduces its holding power. As a consequence, it will result in *slippage*. Pliers' teeth and its cutting edge must be reconditioned or must be replaced. *Mushroom-headed cold chisel* can cause danger when driven with a hammer. The driving force of a hammer may change direction due to the mushroom-like contusion

on the head of the chisel. If this happens, body part is hammered rather than the object itself. Thus, injury is certain.

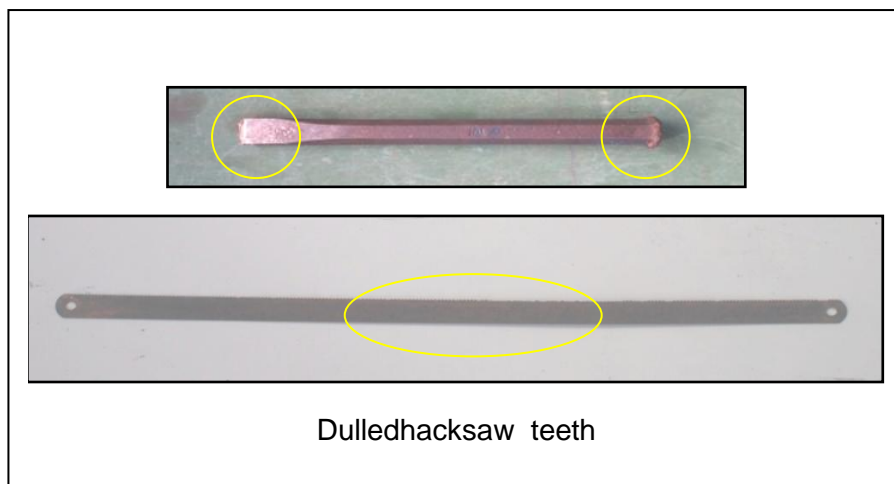

3. **Driving tools.** A swollen striking edge and loose hammer head handle can create a very devastating injury and fatal blow when the head flies out of its handle and hits a delicate part of the body.

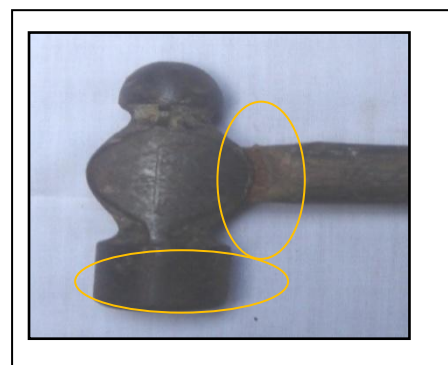

4. **Loosening and tightening tools.**

A slacked wrench or screwdriver is a product of *overused or wrong sized tool* when forcefully used. *Incorrect position of tools or the person doing the job* will create an unbalanced force. When force is applied, the possibility of accident may happen. There is also a tendency of slippage when the surrounding sides of the wrench don't fit squarely with the sides of the bolt or nut being removed or tightened. Therefore, this kind of fault must be addressed right away and the wrench or screwdriver be replaced at once.

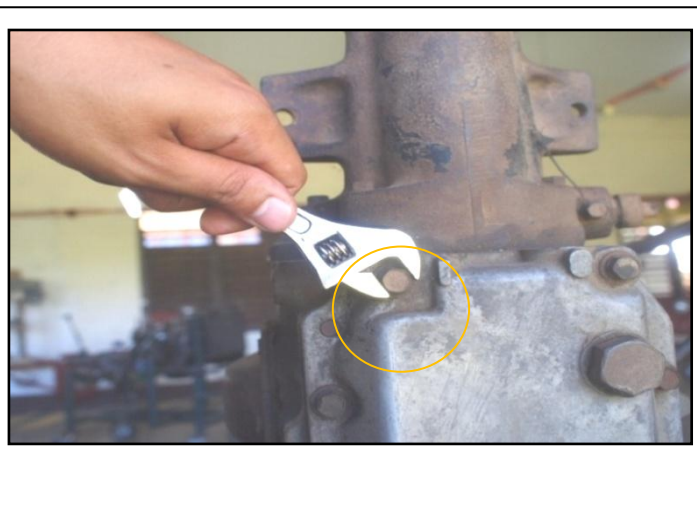

5. **Marking tools.** A bent and dulled tip of marking tool will not give accurate marking. A dulled tip creates blurred lines; therefore, interpretation of lines and dimensions are not precise.

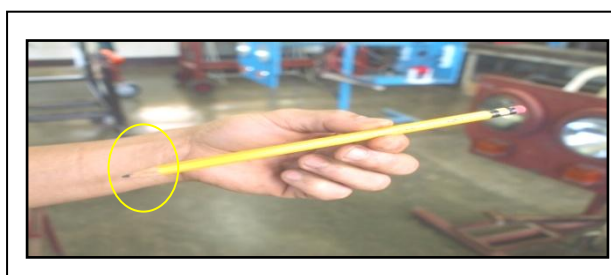

This must be corrected at once. Sharpen tools with the use of an appropriate sharpening gadget.

6. **Measuring Tools.** A measuring tool must be always kept clean. *Dirty, bent, and creased measuring tools* like measuring tape, steel rule, and caliper will give inaccurate reading if the gradation lines are not readable.

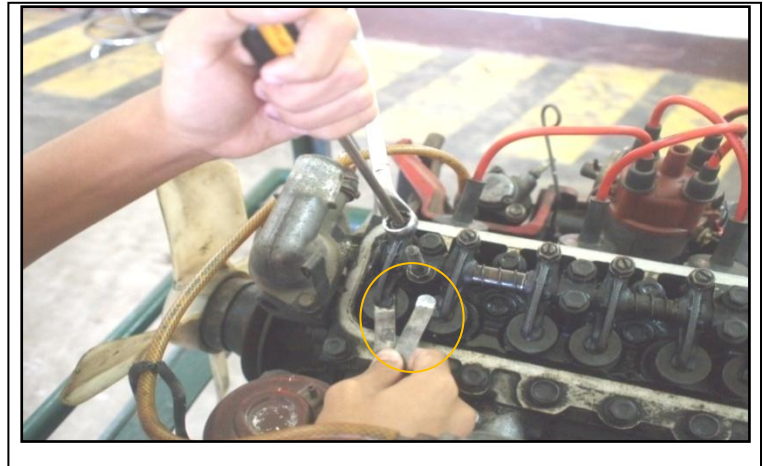

Safety requirements of hand tools

Hand tools come in different sizes, shapes, weights, brands, and designs. These characteristics of hand tools are very important because they give us technical data about their production. These technical data will enable us to know the capacity of tools if subjected to the degree of use. The standard requirements of tools for use and safety are very important on the part of the buyer as well as the user. Without them, they have no bearing at all if not assured with safety features. Tools are engineered and designed to numerous sequence of events when used within the normal working range. To use a tool appropriately, know its safety requirements, to be guided accordingly when you purchase one.

Tools produced in the industry must pass the **Work Equipment Law**. In this law, procedures on the extent, fitness, correctness, and usability of tools and equipment are provided in accordance with specified task. This ensures safety standards before tools are released in the market.

The following are some of the information you need to know about the safety requirements of hand tools:

1. **Technical data.** This will give information about the manufacturer's specifications of the tools produced. The size, weight, production code number, and the brand are usually marked on the body of the item.

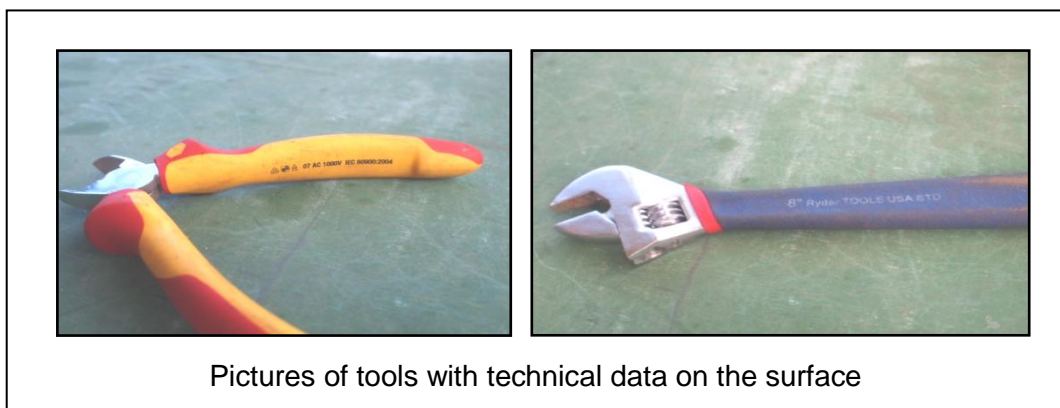

2. **User's manual.** It tells where, when and how the tools are to be used. It also gives information on the limitation of tools if subjected to constant use. In this manual, users are given warning on the possible injury one may get if used incorrectly. It also gives detailed information on how tools are maintained and stored. If tools need to be assembled, the manual gives a step-by-step instructions on how to do the task.

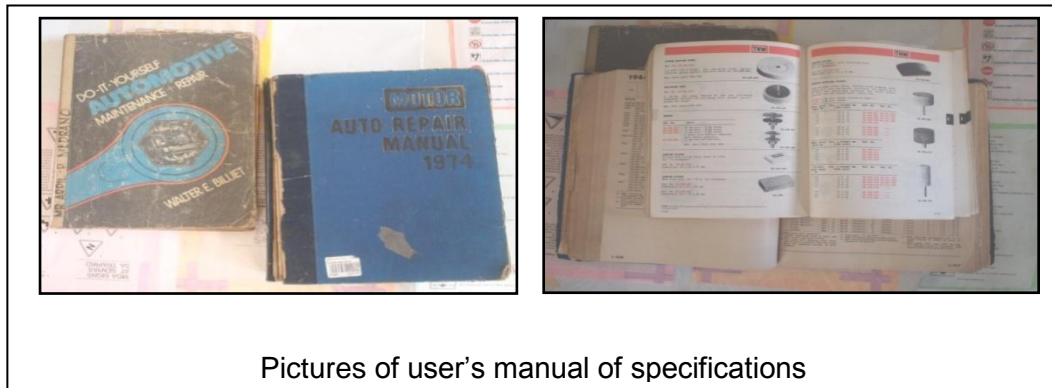

3. **Physical requirements.** Physical requirements of tools have bearing on how they are manufactured. Their good quality must be:
- Tensile strength.* Tools *must be light but durable* so that excessive force in using them is not necessary. In this manner, strain on hands and shoulders are reduced. A tool must be *strong and reliable* to stand the stress of constant use. Tooth edge of hacksaw and chisel *must be tempered and so with a screw driver.*
 - Powerful.* Tools *must not be heavy on the hand side* rather than on the end portion of the driving force, as in a hammer. They must be *considerably long* to give a powerful twisting force as in a wrench and screw or a heavy blow when using hammer. This reduces muscular effort and efficiency of work is achieved.
 - User- friendly.* Tools *must be easy and comfortable to use.* They *must be hand-fit and oval or cylindrically shaped.* A square-shaped handle creates discomfort on palms because of the edge area.

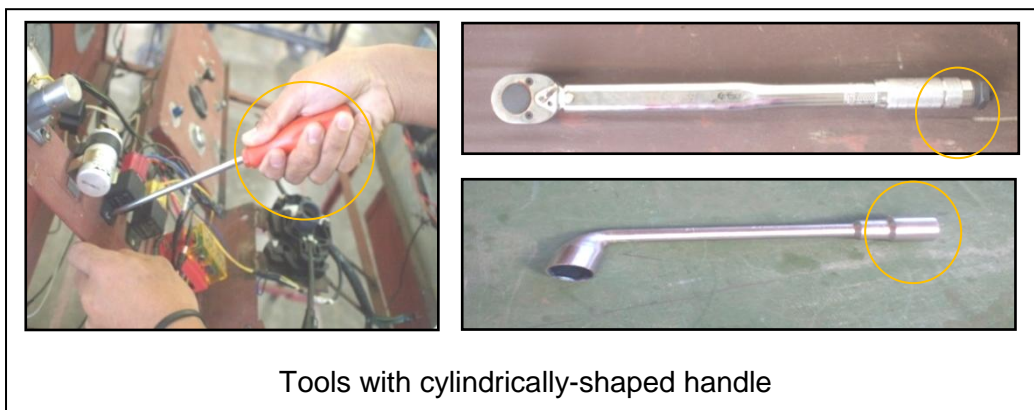

- d. *Safe Tools* must have *gripping surface* on their handles to assure holding power and avoid slip that may lead to injury. *Stopper* must also be on *pointed and sharp-bladed/edged* tools. Driving tools must be provided with *appropriate length of grip*.



- e. *Functionally Accurate*. Tools are especially made to measure like torque wrench. Vernier caliper and feeler gauge *must be technically and functionally accurate*. They *must give correct reading* of division and sub-division of their fractional value or scale. Inaccurate reading gives wrong data or information and may result in severe damage to parts.

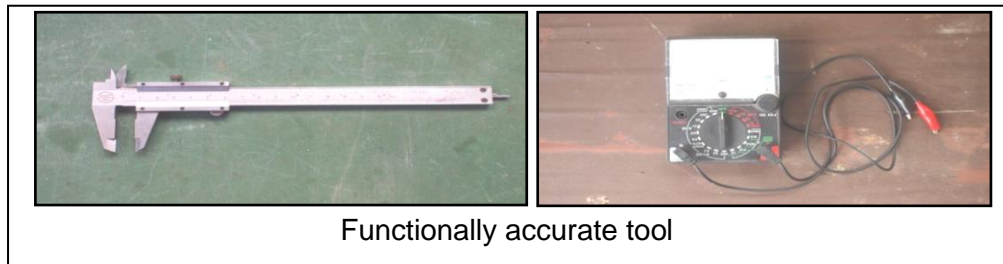



How Much Have You Learned?

Self-check 2.1

Direction: Match Column A with Column B. Write the letter of the best answer.

Column A	Column B
1. Hacksaw	a. used in marking lines in sheet metal
2. Ball peen hammer	b. used in linear measurement of short length or height
3. Long nose pliers	c. generally used for driving or striking work.
4. Metal tape measure	d. used to complete the job of removing the pin
5. Open wrench	e. used for holding or picking small object
6. Drift punch	f. used for cutting pipes, tubing and fairly thick metal
7. Scriber	g. used for light application of loosening and tightening bolts and nuts
8. Feeler gauge	h. used to measure or set gap and clearance between parts of mechanism
9. Steel rule	i. used to loosen and tighten screws
10. Screw drivers	j. used for measuring stock of different sizes of length

Refer to the Answer Key. What is your score?



How Do You Apply What You Have Learned?

Show that you have learned something by doing this activity.

I. **Directions:** Group yourselves. Get your set of tools in your group tool box. Identify the faults of the tools by attaching the “fault slip of paper” Leave a tool without any fault unmarked or clean. Exchange with another group for evaluation.



1. _____

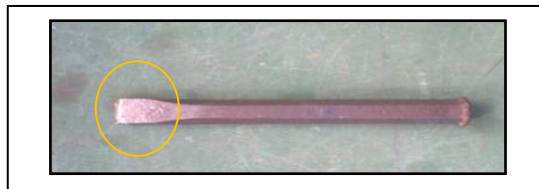

2. _____

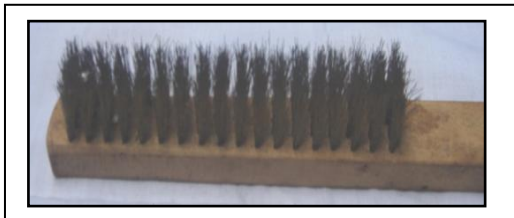

3. _____

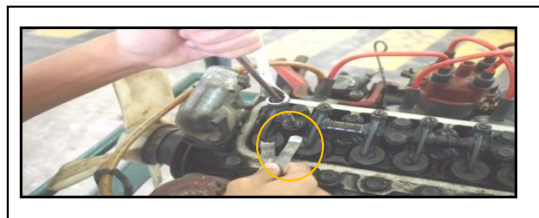

4. _____

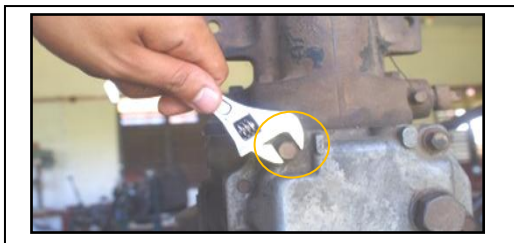

5. _____

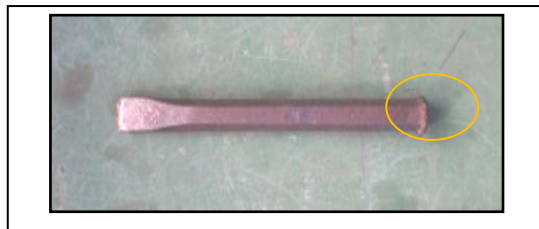

6. _____

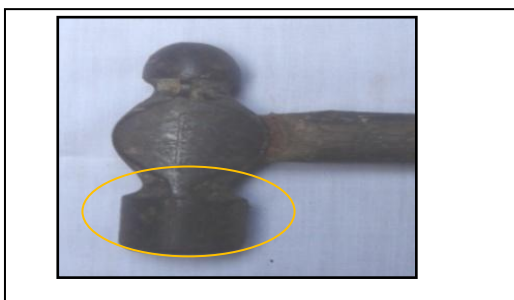

7. _____

8. _____

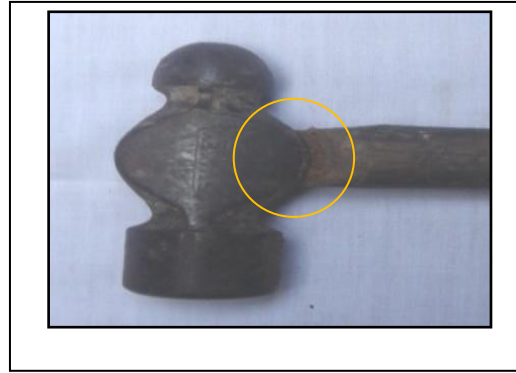
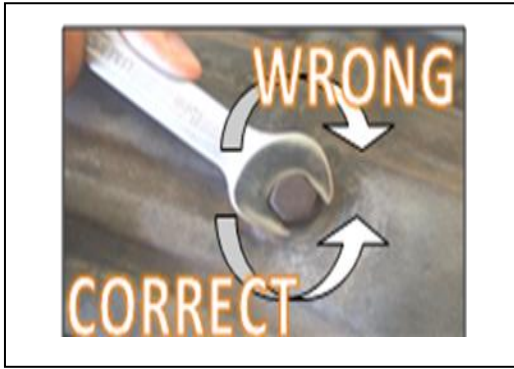

9. _____

10. _____

II. Directions: Reflect on the following questions. Write your answers in your Activity Notebook

1. Which of the following safety requirements of hand tools do you find the easiest? Which one do you find the most difficult? State your reason.

1.1 I Like best....

1.2 I Do not like....

1.3 I suggest some requirements....

Direction. Fill-up the corresponding service procedure with the right tools for the job.

1. Classify the tools by using the Classification Organizer.

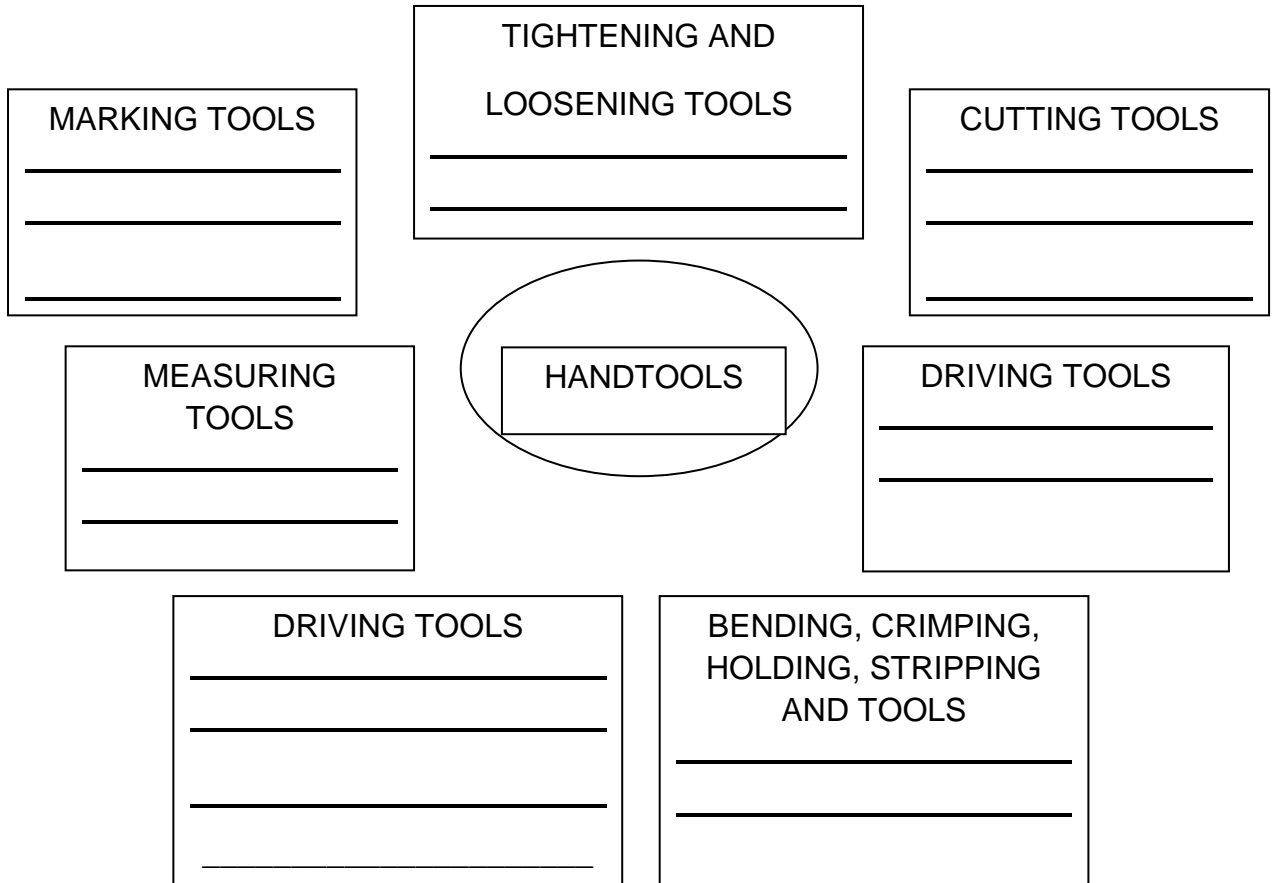

Activity Sheet 2.3

Directions: Make a cut out of the different faulty tools and classify them according to the condition of each one.

Tools	Bent	Creased	Dirty	Dulled	Frayed	Loosed	Slacked	Swelled
1.								
2.								
3.								
4.								
5.								



How Well Did You Perform?

Find out by accomplishing the following job. Remember it is your learning at stake!

Job Sheet 2.1

Title of Job : Cutting a steel bar with a hacksaw.

Materials Required: Mild carbon steel round bar

Tools and Equipment Needed: Bench work, bench vise, hacksaw

Procedure:

1. Select a hacksaw blade suited for the job.



2. Place the hacksaw blade on the frame. Be sure that teeth of the blade is away from the handle.



3. Tighten the hacksaw blade. Be sure that no amount of slack is felt to prevent it from breaking.



A loose hacksaw blade will easily break and a too tight blade will result in frame

4. Set the steel round bar in a vise and clamp.

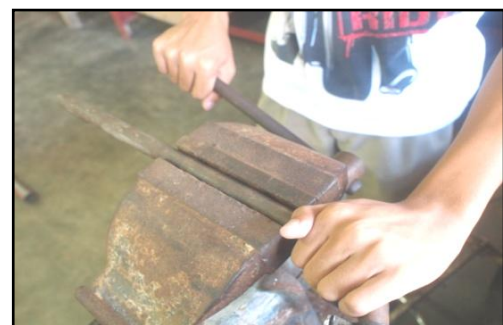

5. Measure the cutting point and mark the surface with a pencil or any appropriate marker.

6. Grasp the hacksaw handle securely with your right hand and the left hand on the front end of the frame.



7. Position your body in front of the vise with your left foot toward the bench and your right foot steady to provide needed balance.



8. With the front end of the hacksaw blade placed on the steel bar, start to cut the bar by applying slight pressure on forward stroke. Release the pressure on the backward stroke.



9. Repeat the process by adding additional pressure on the succeeding stroke.



Be sure to have at least 40-50 strokes per minute.

Be sure that full length stroke is applied.



10. Lessen the pressure when the steel bar is nearly cut to avoid blade from breaking.

11. Clean the hacksaw by wiping it with dry cloth, wipe with a drop of oil. Return the hacksaw in its proper storage.

LEARNING OUTCOME 3

Prepare report of malfunctioning tools

PERFORMANCE STANDARDS

- Malfunctioning tools in unplanned or unusual event are reported.



Materials

1. Inventory sheet
2. Drill bit
3. Grinding wheel
4. Broken wrench
5. Hack saw
6. Record book



What Do You Already Know?

Let us determine how much you already know about preparing a report of malfunctioning tools. Take this test.

Pretest LO 3

Directions: Answer the question by writing the letter of the best answer.

- Tools must be used to their maximum_____.
A. effectiveness
B. enablement
C. elasticity
D. endurance
- A tool that has _____ been defective creates headache and irritation.
A. frequently
B. once a year
C. once a month
D. seldom
- Faulty tools must be recorded, _____ and reported at once.
A. condemned
B. thrown
C. marked
D. used
- Tools must be set apart according to its _____.
A. design
B. shape
C. serviceability
D. style
- A faulty tool once used _____ work efficiency.
A. drives
B. precedes
C. increases
D. reduces



What Do You Need To Know?

Read Information Sheet 3.1 very well then find out how much you can remember and how much you learned by doing the Self-check 3.1.

Information Sheet 3.1

Preparing report for malfunctions of hand tools in unplanned or unusual events

Tools are made for use. Its life cycle must be used to its maximum effectiveness. It is designed to give its purpose so that work becomes easy and efficient. A tool that is 100 percent usable brings joy to the one using it but a faulty tool is unsafe to use. It is not recommended for use because of its risk to workplace activities. A faulty tool creates headache and irritation. That is why; faulty tools must be recorded, marked, and reported at once.

Defective tools can be repaired according to company procedure. This is essential in restoring back their technical specifications. A good example is the drill bit's angular cutting edge. If standard procedure is not followed in sharpening its edge, it will not cut effectively compared to the original specifications. Partially defective tools can be reconditioned for another form of use. Heavily damaged tools not fit for human use are condemned and disposed. Tools must be set apart according to their serviceability. It is important that defective or faulty tools must be marked. Markings will mean that they are not to be used and are intended for repair or reconditioning.

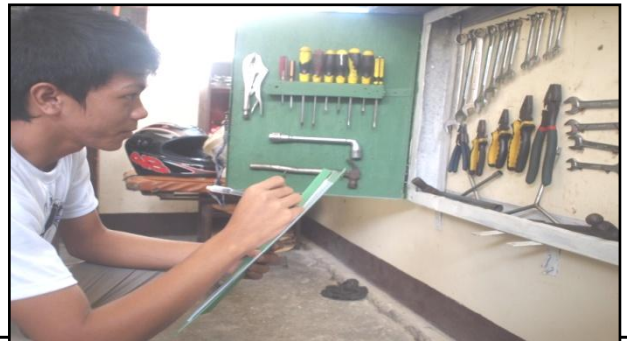

Below are some effects of a defective tool that can result in the following consequences:

1. *Reduces work efficiency.* It decreases work effectiveness and additional time allotment is needed to finish the work. Therefore, delay of work is sure.

2. *Lessens the concentration of the user.* Frequent breakdown or change of tools because of its faulty condition affects the mental focus of the user. It creates anxiety and apprehension thus delaying the work instead of finishing it on time.

3. *Decreases credibility.* Competitiveness is the language of service. Once the customer perceives that a worker or a serviceman uses faulty tools without giving notice of it, it lessens their trust and confidence.

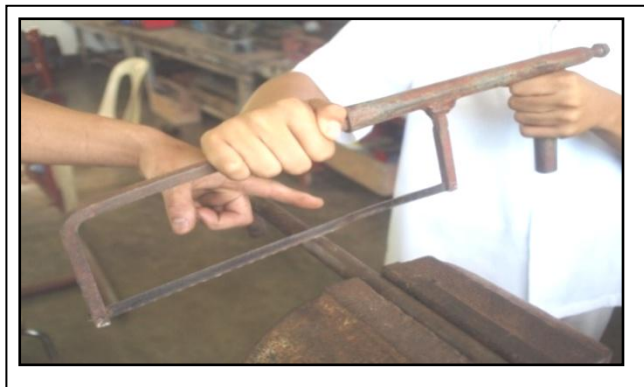

In order to avoid these situations, proper inventory of tools must be conducted, recorded and updated. Reporting the condition of good, faulty and damaged tools will give an account of their present condition. It will give a basis for disposal, if damage is severe or beyond recovery; for recycling, if the fault can be corrected and repaired and reused to another form of service. A broken hacksaw can be recycled to another form like converting it to a sharp blade for stripping electrical wire. Maintenance of tools entails cleaning and doing simple repair in order to prolong their use.

To give you an idea of what an inventory, requisition and account of tools are, a basic sample of forms are given.

Form 1- IT Form

SAMPLE INVENTORY OF TOOLS

Item No.	Source of Fund	Description	Quantity	Remarks
001	National	Open wrench, mm. drop forged, Sakura, Japan	1 set, 12 pcs	
002	-do-	Box wrench, in. drop forged, Sakura, Japan	1 set, 12 pcs.	
003	-do-	Screwdriver, flat, hardened steel, Stanley, U.S.A.	1 set, 6 pcs.	
004	-do	Screwdriver, Phillips , hardened steel, Stanley, U.S.A.	1 set, 6 pcs.	
005	SEF	Hammer, ball peen 16 oz., high grade steel, Proto, U.S.A.	6 pcs.	

This is to certify that inventory of tools have been made on April 25, 2011.

Prepared and Submitted by:

Property/Supply Officer

Conferred:

Department Head

CERTIFIED TRUE AND CORRECT:

Principal

SAMPLE ACCOUNT OF TOOL CONDITION

Item No.	Source of Fund	Description	Remarks / Condition		
			Good	Defective	Condemnable
001	National	Open wrench, mm. drop forged, Sakura, Japan			
002	-do-	Box wrench, in. drop forged, Sakura, Japan			
003	-do-	Screwdriver, flat, hardened steel, Stanley, U.S.A.			
004	-do	Screwdriver, Phillips , hardened steel, Stanley, U.S.A.			
005	SEF	Hammer, ball peen 16 oz., high grade steel, Proto U.S.A.			

This is to certify that inventory of tools have been made on April 25, 2011.

Prepared and Submitted by:

Property/Supply Officer

Conferred:

Department Head

CERTIFIED TRUE AND CORRECT:

Principal



How Much Have You Learned?

Self-Check 3.1

Directions: On your activity notebook, answer the following self-reflection and discuss it in the class.

MINUTE PAPER

Today, I have learned that:

1. _____
2. _____
3. _____

But, I'm a little bit confused with:

1. _____
2. _____
3. _____

I still want to learn more on:

1. _____
2. _____
3. _____



How Do You Apply What You Have Learned?

Show that you learned something by doing this activity.

Activity Sheet 3.1

Directions: Visit an automotive shop in your community. Introduce yourself as an Automotive Servicing student. Request for a copy of their inventory of tools. Discuss it with your classmates.

LEARNING OUTCOME 4

Maintain hand tools

PERFORMANCE STANDARDS

- Routine maintenance of tools are undertaken according to standard operational procedure, principles and techniques.
- Tools are stored safely in appropriate locations in accordance with manufacturer's specifications or standard operating procedure.



Materials

1. Goggles
2. Adjustable wrench
3. Vise grip
4. Drill bit
5. Grinding wheel
6. Fire extinguisher



What Do You Already Know?

Let us determine how much you already know about maintaining hand tools. Take this test.

Pretest LO 4

Directions: Put a check (✓) mark in the appropriate column that best describes your present level of knowledge of each enlisted competency.

Knowledge	I do not know it	I am learning to know it	I want to learn more	I know it very well
1. Know the routine maintenance of Tools				
2. Know how to maintain tools				
3. Know how to store tools				
4. Know the standard operating procedures in storing tools				
5. Know the principles and techniques in keeping tools				



What Do You Need To Know?

Read Information Sheet 4.1 very well then find out how much you can remember and how much you learned by doing the Self-check 4.1.

Information Sheet 4.1

Standard operational procedure, principles and techniques in maintaining tools

Tool management is a manifestation of a good serviceman or any person working with tools. The way a person manages his tools has bearing on the way he manages his personal property.

Much to say, a good tool manager is efficient in listing and keeping records. Up-to-date records of tools both the old and newly bought must be entered to the roster of tools. Basically, fundamental principles and techniques in maintaining tools at the minimum level is good enough but the more routine schedule you make, the better. It will only take a matter of one to two hours to maintain tools. Sometimes, it takes more than what expected time is consumed depending on the extent of the number and size.

One of the maintenance schemes of the Provision and Use of Work Equipment Regulations 1998 (PUWER) under the Law on Tools and Maintenance is to ensure the safekeeping and securing of the equipment including tools.

This law helps in identifying safety procedure before it grows into a severe hazard.

In order to avoid these problems, some principles must be followed. Neglect of these principles opens a doorstep to risk and danger to life and property.

• OPERATIONAL PROCEDURE IN TOOLS AND EQUIPMENT MAINTENANCE

1. **SAFE USE.** Assurance of safe use is expected. This can be done by knowing the purpose, application, and requirement of tools and equipment. Without this knowhow, the user will only be guessing and wrong use is expected. Risk of injury is more likely to happen. Shop / industry owners are expected to train their workers. This will build morale and reduce danger.

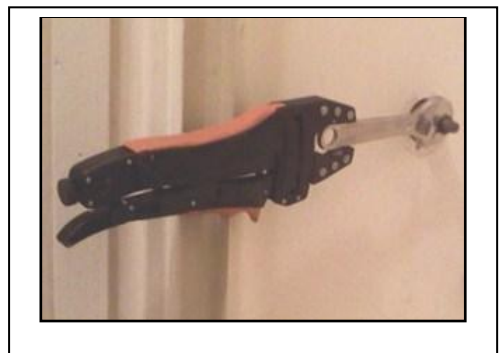

2.

2. **SAFEKEEPING.** Regular maintenance of tools and equipment through safekeeping must be a part of the health and safety of users and owners. Dangers to theft and exposure to moisture is avoided, property is taken care of, and risk is evaded. Putting the tools, equipment and paper documents such as manual of specifications in a very protected but easy to retrieve place is a good habit of safekeeping. Storage room must be properly locked and ventilated.



3. SAFETY SIGNS AND SYMBOLS. By putting safety signs and symbols, users are informed and warned of what to do and what not to do. Risk is limited and put in control. Specific safety signs for mechanical, electrical, pneumatic, and hydraulic must be clearly defined and placed in a visible area.



4. SAFETY PROTECTION. The use of Personal Protective Equipment (PPE) is necessary. Safety gears must be worn properly. Suitability of PPE to the workplace must conform with the work being done. It must be comfortable so that user will not be irritated. The PPE can control health risk and decrease possibility of threat or injury. For face protection, eye wear, goggles, and safety shield used in welding are used. The body protection such as aprons or cover-all garment serves as protection for the frontal body. High grade, heat and chemical resistant hand gloves protect the hands and a simple dust mask or respirator can ward off chemical fumes and dust for the respiratory system. Appropriate shoes can also protect from accidental fall of metallic parts. Not only that, safety in the workplace is also included. Fire extinguishers play a vital role in reducing and totally putting out the fire. Saw dust is a good cleaner for spilled oil on the floor.





How Do You Apply What You Have Learned?

Show that you learned something by doing this activity.

Activity Sheet 4.1

Directions: Get a partner. Choose one of the competencies you would like to demonstrate.

1. Safe use of hand tools.
2. Proper safekeeping and storage of hand tools.
3. Interpreting safety signs and symbols.
4. Using safety Personal Protective Equipment (PPE)



How Well Did You Perform?

Find out by accomplishing the Scoring Rubric honestly and sincerely. Remember it is your learning at stake!

PERFORMANCE ASSESSMENT

Name : _____ Year & Section: _____

Course: _____ Time Allotment: _____

Module Title: _____ Grading Period _____

Unit of Competency	Tasks	Date	Time		Score	Performance Level
			Begun	Finished		
LO1 Using Hand tools	Classify tools according to use.					
LO2 Prepare and Use Hand tools	Use Hand tools.					
LO3 Create Report of Malfunctioning Tools	Prepare Report of Malfunction Tools.					
LO4 Maintaining Hand tools	Clean and store tools in safe place.					

Average: _____

Performance Rubrics

Criteria	5	3	1
Proficiency	Performs the task with competence and exceptional performance	Performs the task with competence and with standard performance	Performs the task with competence but below standard performance
Accuracy	Performs the task with no error	Performs the task with at least 1-2 errors	Performs the task with at least 3-5 errors
Completeness	Performs all the steps in sequence	Performs the task with at least 2-3 steps not met	Performs the task with at least 3-5 steps not met
Safety	Follows all the safety practices as set in the guidelines	Follows the safety practices with at least 1-2 safety measures not met	Follows the safety practices with at least 3-5 safety measures not met

TOTAL _____

RATING SCALE: Points Earned (S) Numerical Rating (PL) Descriptive Rating (PL)

21 – 25	91 - 100	Outstanding
16 – 20	86 - 90	Very Good
	11 – 15	81 - 85
06 - 10	76 - 80	Fair
01 - 05	71 - 75	Needs Improvement

WHAT IS YOUR SCORE? _____



How Do You Extend Your Learning?

1. Surf internet and watch video on how tools are used, cleaned and maintained.



Congratulations! You did a great job! Rest and relax a while then move on to the next lesson. Good luck!

REFERENCES

- Swing Crispin, Frederic, Dictionary of Technical TermsThe Bruce Publishing Co.: 1948.
- Chilton's Easy Car Care. Chilton Book Company. 3rd Ed. Chilton Way, Radnor, PA 19089
- Stockel, Martin W. Auto mechanics Fundamentals. The Goodheart - Willcox Company, Inc. 1978
- The Oxford Dictionary of Current English. New Revised Ed. Oxford University Press, 1998.

- Popular Mechanics Guide To Auto Basic Repair and Maintenance. Book Division The Hearst Corporation, New York, NY
- www.google.com.ph
- en.wikipedia.org

LESSON 2

Perform Mensuration and Calculations



LEARNING OUTCOMES:

At the end of this Lesson, you are expected to do the following:

- LO 1. select measuring instruments and carry out measurements and calculations; and
- LO 2. maintain measuring instruments.

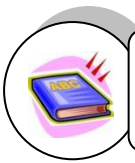

Definition of Terms

Accuracy- the preciseness of result as in mathematical solution which is free from error

Calculation - a process of working out the answer by solving mathematical problems

Compression pressure gauge - an instrument for checking the compression pressure of the engine

Maintain - ensure that something continues to work properly by checking it regularly and making repairs and adjustments if required

Maintenance - the periodic upkeep something such as tools, equipment or workplace in a regular basis

Measuring - an activity or task of getting the amount, size or quantity of a certain thing or stock/parts

Oil pressure gauge - an instrument that indicates the flow of oil pressure in the engine

Safety - the freedom from danger or risk

Standard procedure- an established, prescribed way of doing a task or series of action

Techniques - course of action of skill used in specific task

Tolerance - the ability of parts or components to endure deviation from standard limit within which it is allowed without harmful effect

V.O.M. tester - an instrument used in checking the resistance, voltage and current

LEARNING OUTCOME 1

Select measuring instrument and carry out measurement and calculations

PERFORMANCE STANDARDS

- Object or component to be measured is identified.
- Correct specifications are obtained from relevant source.
- Appropriate measuring instrument is selected in line with job requirement.
- Calculations needed to complete work/task are performed and checked using the fundamental operation of mathematics.



Materials

- Vernier Caliper
- Micrometer caliper
- Dial gauge
- V.O.M. tester
- Clamp ammeter
- Multi tester
- Megger Tester
- Engine Analyzer
- Timing/Strobe light
- Vacuum gauge
- Compression gauge
- Radiator pressure tester
- Fuel pump pressure tester
- Oil pressure gauge
- Temperature gauge



What Do You Already Know?

Let us determine how much you already know about selecting measuring instrument. Take this test.

Pretest LO 1

Directions: To determine your prior learning, answer the questions by writing the letter of the best answer.

- Measurement can be applied by means of:
A. driving tool
B. marking tool
C. measuring tool
D. punching tool
- Precision measuring instruments cannot be squarely compared to the one used for ____ jobs.
A. electrical
B. hit and miss
C. mechanical
D. pneumatic
- In getting the bearing diameter or shim thickness, using _____ tool is much better.
A. divider caliper
B. inside caliper
C. steel rule
D. vernier caliper
- Parts that need to be serviced must have a corresponding data of specifications _____.
A. manual
B. sequence
C. specifications
D. symbol
- The bolt's mechanical strength or stretching point will easily give up and consequently break if it exceeds too much _____.
A. data
B. resistance
C. tensile strength
D. torque
- A dial gauge is used to measure _____.
A. backlash
B. end space
C. gap
D. space
- Mechanical measuring tool like torque wrench have limited _____.
A. cost
B. price
C. tolerance
D. weight
- To check the ignition timing of ignition system, use _____.
A. dim light
B. flashlight
C. headlight
D. strobe light
- Calculation can be solved by using mathematical _____.
A. formula
B. strategy
C. system
D. type
- The distance travelled by a vehicle is expressed in terms of miles (mi) or _____.
A. kilometer (km)
B. liter (L)
C. meter (m)
D. yard (yd)



What do you need to know?

Read Information Sheet 1.1 very well then find out how much you can remember and how much you learned by doing Self-check.

Information Sheet 1.1

The need for measuring instruments

Modern measuring instruments evolved in a very fast and changing time. Year after year, from human to non-human use, new and sophisticated measuring instruments are innovated.

In automotive application, vehicles are innovated and modified year after year. Measuring instruments used from engine output testing like dynamometer to engine tune-up like engine analyzer are used even in small auto shop industry.

With the emerging trends of measuring instruments, the need for accurate data is very much important. In automotive servicing, the language of competition cannot be denied. Car owners go to car repair shop with updated gadgets. They thought that repair is not guessed but really gives a fast movement of digital or analogue reading of the gadget. Just one flick of a finger is needed to get the job done.

Precision measuring instruments cannot be squarely compared to the one used for mechanical jobs. Tools for mechanical jobs are heavy and need strong force to operate whereas precision instruments are light, sensitive and calibrated to get accurate result. A slight difference of reading invites occurrence of error.

Essentially, having a simple or sophisticated precision measuring tool is not a fad anymore but a necessity that must be seriously considered.

Measuring instruments and its application

Very importantly, your knowledge of the different types and applications of measuring instruments play a vital role in the development of your competency.

Like any other tasks, components to be measured must first be identified before using any tools. Identification of components will determine the right tools to be used. It will make your work easier and faster without going back and forth because of wrong choice of tools. To understand it more, a precision instrument like vernier caliper is not a good in getting the diameter of oil filter. But getting the diameter of bearing or thickness of shim using this kind of precision tool is much better.

In order to be clearer, the following precision instruments/tools basically used in automotive application are the following:

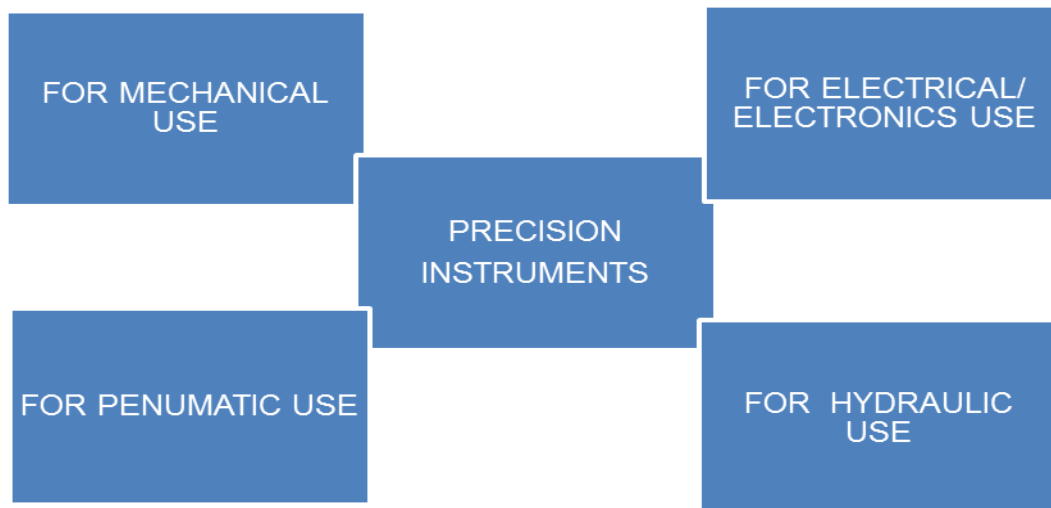

A. For Mechanical Use

1. The **Vernier and Micrometer calipers** are both precision instrument that can measure even the smallest and tiniest thickness and diameter of an object. Vernier or micrometer calipers are usually used in measuring the diameter of engine crankshaft and camshaft journals pistons and valve adjusting shims. These engine parts need to be measured in a precise way.

Verniers and Micrometers can be bought equipped with digital or analogue reading. This will lessen the time consumed in analyzing the reading of data because of the direct data available as you measure the part.



2. **Dial gauge** is an instrument that measures 'thrust' or 'backlash'. A backlash is the result of force that comes from an abnormal clearance or gap between two parts as in the differential gears. When two parts wear-out, slack is developed and backlash is the result of it. Dial gauge is also used in getting the clearance of engine valves. It is more accurate than feeler gauge. The movement of pointer in the dial gauge determines the amount of backlash being measured.



B. For Electrical Use

1. **V.O.M. tester** is a multi tester. It is an electrical instrument that measures or tests the voltage, resistance and current in a circuit. V.O.M. can be digital or analogue. Digital reading have digitized screen and a direct number of data can be read at once. Analogue reading have pointer that determines the reading on the screen.



When testing for resistance, external power from the source must be disconnected because V.O.M. tester is equipped with built-in battery as source of power. If external power source is not disconnected, the tester itself will be damaged. When testing for voltage, tester is connected across the lines of the circuit. But, when the current is tested, the tester prod is connected in series of the circuit. A **Clamp ammeter** is also available in the market. This kind of tester is clamped in the wire itself. It measures current in amperes.

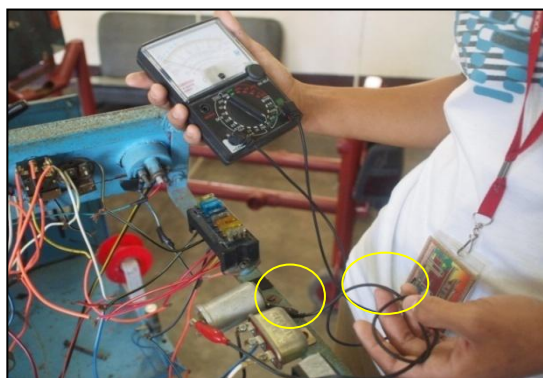

Connection of tester when testing resistance



Connection of tester when testing voltage

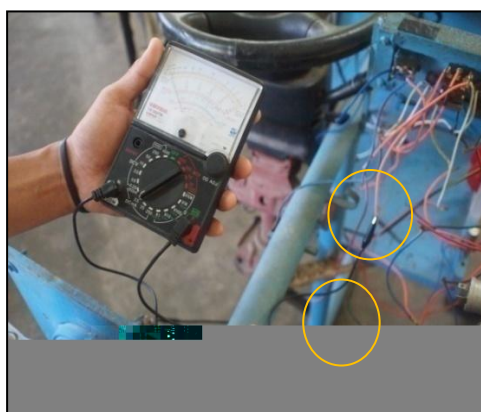

Connection of tester when testing current

2. **Megger Tester** is a test instrument in finding out grounds and shorts in a motor. A good example to test is the starter motor. When the starter motor is subjected to a megger test, a flat, thin piece of metal (like a hacksaw blade) is placed above the starter motor. When the megger tester is turned 'on' and starter motor is rotated, a spot where a hacksaw blade is attracted means that the starter motor is faulty and need to be repaired or replaced.



3. **Engine Analyzer** is a compact instrument that tests and measures the following:
 - 3.1 Contact point resistance
 - 3.2 Ignition coil resistance
 - 3.3 Battery voltage
 - 3.4 Ignition current flow
 - 3.5 Engine revolution per minute (RPM)
 - 3.6 Dwell /Cam angle
 - 3.7 Alternator diode



4. **Timing/Strobe light** is a device that produces stroboscopic effect from ignition pulses. Ignition timing is achieved by aligning the timing marks on the crankshaft pulley and timing cover of the engine.



Timing light in use



C. For Pneumatic Use

1. **Vacuum gauge** is an instrument that measures the atmospheric pressure drawn by the engine. It is also used to find out the air-fuel ratio of the engine.



2. **Compression gauge** is an instrument that measures the compression pressure of the engine cylinder.



3. **Radiator pressure tester** is used to test the cooling system for internal and external leaks and to make sure that it has the ability to hold pressure.

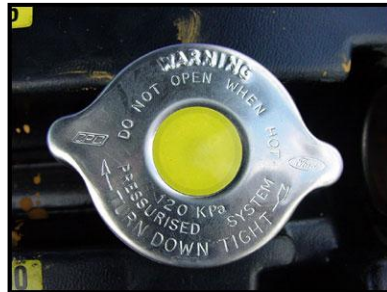

Radiator pressure tester



D. For Hydraulic Use

1. **Fuel pump pressure tester** is an instrument that has the capability to check the pump pressure.



2. **Oil pressure gauge** is an excellent indicator instrument that determines the pressure of oil flowing.

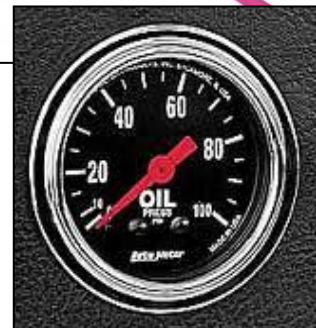

3. **Temperature gauge** is an instrument that determines if the engine temperature is normal or overheating.



Techniques in measuring and determining Tolerance of parts

There are many ways in measuring a part or component but there is difficulty when using precision instruments specially those that require minute data. The process in which parts are measured needs to have a corresponding data of specifications so that a clear and objective result is attained. Using specific measuring instrument for a specific part or system to be measured is highly recommended. Specific measuring instrument is designed for specific part or system. Using different instruments other than what is required will give you vague or incorrect result. For these reasons, determining to find out the tolerance will give you difficulty.

In order to apply techniques and determine tolerance, some considerations are recommended for consideration:

1

- Use the Manual of Specifications

2

- Use the Principles of General Rule

3

- Use of Professional Experience

1. **Use the Manual of Specifications.** The availability of specifications manual will speak for the tolerance of certain part or system. User's manual will tell you the procedures on how it check and the negative effect if it exceeds the standard limit value of part or system. Without this manual, the user will only be guessing on the corresponding value of measurements. If neglected or allowed in this manner, the parts or system will easily give up.

A good example is the kind of bolts being used. A bolt made of high grade carbon steel has a big difference compared with a bolt made of low carbon steel even if it has the same size. When a low carbon steel bolt is tightened using the torque data used for high grade carbon steel will easily give up and break. This is due to the fact that it cannot withstand the tolerance used in high grade steel carbon steel bolt. The bolt's mechanical strength or stretching point easily gives up and consequently breaks.

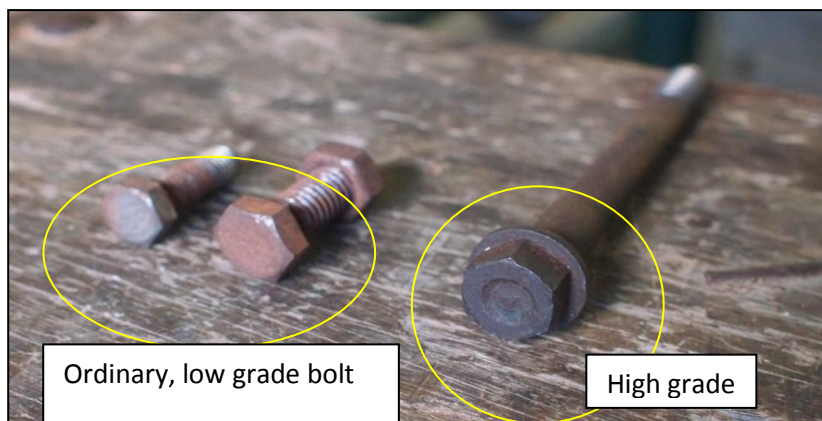

Ordinary and high grade bolt

Vehicle electrical component like ignition coil primary and secondary windings have specified resistance data but tolerance is also given. It means that when the resistance reading is above or below the standard reading but within the limit of its tolerance, it is said that the resistance is acceptable or tolerable.

The use of precision instruments and tools has tolerance also. Mechanical measuring tool like torque wrench have tolerable life cycle. If it exceeds its cycle or length of used, a metal fatigue will be developed. Its effectiveness to accurately measure the tightness of bolts or nuts is affected. That is why it must be calibrated before and after use. Delicate precision tool like Vernier and Micrometers must be used with caution. It is made with a very light material that a sudden impact or force will damage its scale and calibration.



Ignition coil on test

Unlike electrical/electronics precision instruments sometimes, a wrong selection of range is unintentional. In V.O.M, a selected 110 voltage range when tested in a 220 volts line will instantly create damage to the instrument. That is why careful steps must be observed when using delicate precision instrument

2. Use the Principles of General Rule. Sometimes, a manufacturer allows a general rule when considering tolerance of parts or systems. They include plus (+) or minus (-) rule. Even with the availability of specifications manual, manufacturers accept it but do not tolerate using it even though it does not cross the maximum limit of tolerance. Not all parts or systems can be applied with this kind of principles. The extent of tolerable limit must be determined so that the outcome of the process can be achieved without affecting other factors.

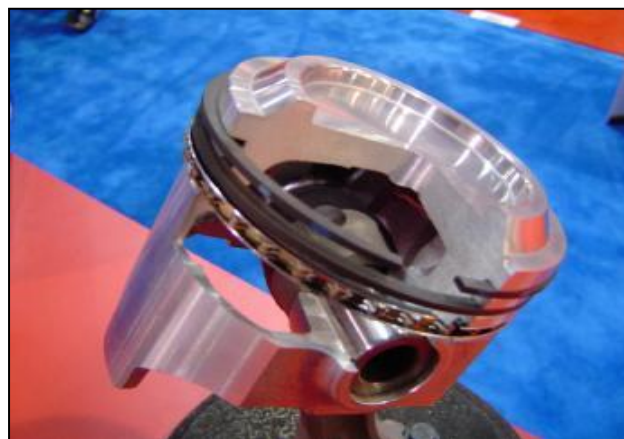

The application of piston ring end clearance is a good example. Even without the aid of specifications manual, the principle of general rule is applied by multiplying the piston diameter by three thousandths of an inch (.003 in”) and you will get the acceptable piston ring end clearance.

3. Use of Professional Experience. This can be done if a person or user has vast, wide and long experience working on the specific task. A novice worker must not involve himself in duplicating this kind of ability. An experienced one because of his long immersion in specific tasks have become expert and remember the applicable specifications of a certain part or system including the correct tolerance.

Methods of calculation/conversion of units of measurement using mathematical formula

Measurement is the process of finding out the physical quantity in terms of time, distance, quantity and economy. The word measurement comes from the Latin word *mēnsūra* and the science of measurement is called Metrology.

Early history had no standard of measurement. It was only over time where people agreed and accepted to use it for uniformity and necessity. Later on, a means of standardizing measurement was established to avoid dishonesty and deceit.

The era of measurement continued to develop into a more suitable and scientific way. Later on, methods of calculations were scientifically done as a way of solving number problems and were generally accepted in education, government offices, business and personal used.

There are two widely accepted and recognized used systems of measurement. The International System (SI) and the English systems. The SI is expressed in metric system of measurement which is expressed in meter for length or distance and kilogram for mass/weight. Whereas the English system is expressed in inches or mile for length/distance and ounce or pounds for mass/weight.

In automobile its systems are also measured. Whether it functions or not, its kinetic and static energy can be measured. When the vehicle runs, it is measured by the distance travelled in terms of miles(mi) or kilometers (km). When it comes to speed it is measured by miles or kilometers per hour. When it comes to engine speed it is expressed in revolution per minutes (rpm).

Below is a sample Systems of Measurement chart of both English and Metric with corresponding conversion

MEASUREMENT SYSTEMS

L E N G T H			
12 inches	1 foot	1 kilometer	1000 meters
36 inches	1 yard	1 hectometer	100 meters
3 feet	1 yard	1 decameter	10 meters
5,280 feet	1 mile	1 meter	1 meter
16.5 feet	1 rod	1 decimeter	0.1 meter
320 rods	1 mile	1 centimeter	0.01 meter
6 feet	1 fathom	1 millimeter	0.001 meter

WEIGHT			
27.34 grains	1 dram	1 tonne	1,000,000 grams
438 grains	1 ounce	1 kilogram	1,000 grams
16 drams	1 ounce	1 hectogram	100 grams
16 ounces	1 pound	1 dekagram	10 grams
2000 pounds	1 short ton	1 gram	1 gram
2240 pounds	1 long ton	1 decigram	0.1 gram
25 pounds	1 quarter	1 centigram	0.01 gram
4 quarters	1 cwt	1 milligram	0.001 gram
VOLUME			
8 ounce	1 cup	1 hectoliter	100 liter
16 ounces	1 pint	1 decaliter	10 liters
32 ounces	1 quart	1 liter	1 liter
2 cups	1 pint	1 deciliter	0.1 liter
2 pints	1 quart	1 centiliter	0.01 liter
4 quarts	1 gallon	1 milliliter	0.001 liter
8 pints	1 gallon	1000 milliliter	1 liter
AREA			
144 sq. inches	1 sq. ft.	100 SQ. millimeters	1 sq. centimeter
9 SQ. feet	1 sq. yard	100 SQ. centimeters	1 sq. decimeter
43, 560 sq. ft.	160 sq. rods	100 SQ. decimeters	1 sq. meter
160 sq. rods	1 acre	10,000 sq. meters	1 hectare
640 acres	1 sq. mile		
TEMPERATURE			
FAHRENHEIT		CELSIUS	
32 Degrees F	WATER FREEZES		0 Degrees C
68 Degrees F	REASONABLE ROOM TEMPERATURE		20 Degrees C
98.6 Degrees F	NORMAL BODY TEMPERATURE		37 Degrees C

173 Degrees F	ALCOHOL BOILS	78.34 Degrees C
212 Degrees F	WATER BOILS	100 Degrees C

An orderly manner and systematic way of calculation is necessary. This can be done by employing some means of mathematical formula. Having this kind of system will not only simplify the job of computation but will arrive in a definite and correct answer to the problem.

Aside from having a chart of conversions, it is a fundamental need that you must know how to calculate some simple computation of measurements. Although what you need can be found in the chart it is still good that you know basic use of mathematical formula in solving numerical problems. There will be time that you will be challenged to make computations. Having this knowledge is an advantage on your part.

To mention are some physics applied in automotive servicing.

- A. **Temperature** – is the degree of the hotness and coldness of a body. It is expressed in degrees Fahrenheit ($^{\circ}\text{F}$) or in degrees Celsius ($^{\circ}\text{C}$) or in SI unit for temperature is Kelvin (K).

TEMPERATURE CONVERSION TABLE		
TO CONVERT	EQUATION	EXAMPLE
Celsius to Fahrenheit $^{\circ}\text{C}$ to $^{\circ}\text{F}$	$^{\circ}\text{F} = \left[\frac{9 \times ^{\circ}\text{C}}{5} \right] + 32$	Convert 50°C to $^{\circ}\text{F}$ $^{\circ}\text{F} = \left[\frac{9 \times 50}{5} \right] ^{\circ}\text{C} + 32 = 122^{\circ}\text{F}$
Fahrenheit to Celsius $^{\circ}\text{F}$ to $^{\circ}\text{C}$	$^{\circ}\text{C} = \frac{5}{9} \times \left[^{\circ}\text{F} - 32 \right]$	Convert 122°F to $^{\circ}\text{C}$ $^{\circ}\text{C} = \frac{5}{9} \times \left[122^{\circ}\text{F} - 32 \right] = 50^{\circ}\text{C}$
Celsius to Kelvin $^{\circ}\text{C}$ to K	$\text{K} = ^{\circ}\text{C} + 273$	Convert 50°C to K $\text{K} = 50^{\circ}\text{C} + 273 = 323 \text{ K}$
Kelvin to Celsius K to $^{\circ}\text{C}$	$^{\circ}\text{C} = \text{K} - 273$	Convert 323 K to $^{\circ}\text{C}$ $^{\circ}\text{C} = 323 \text{ K} - 273 = 50^{\circ}\text{C}$



How Much Have You Learned?

Self-Check 1.1

- I. **Directions:** Select the best answer. Write the letter only. Use your Activity Notebook for your answers.
- Standardizing measurement was established to avoid _____ and deceit.
A. courage
B. dishonesty
C. honesty
D. tax
 - The era of measurement continued to develop into a more suitable and _____ way.
A. logic
B. physical
C. magic
D. scientific
 - 12 inches is equivalent to _____ foot.
A. 1
B. 12
C. 24
D. 36
 - When the vehicle runs, it is measured by the distance travelled in terms of mile (mi) or _____.
A. kilometer (km)
B. liter (L)
C. meter (m)
D. Yard (yd)
 - The boiling of water in degrees Fahrenheit is
A. 200°F
B. 212°F
C. 214°F
D. 216°F

II. **Directions:** Fill up the blanks with the tools used for each precision instrument.

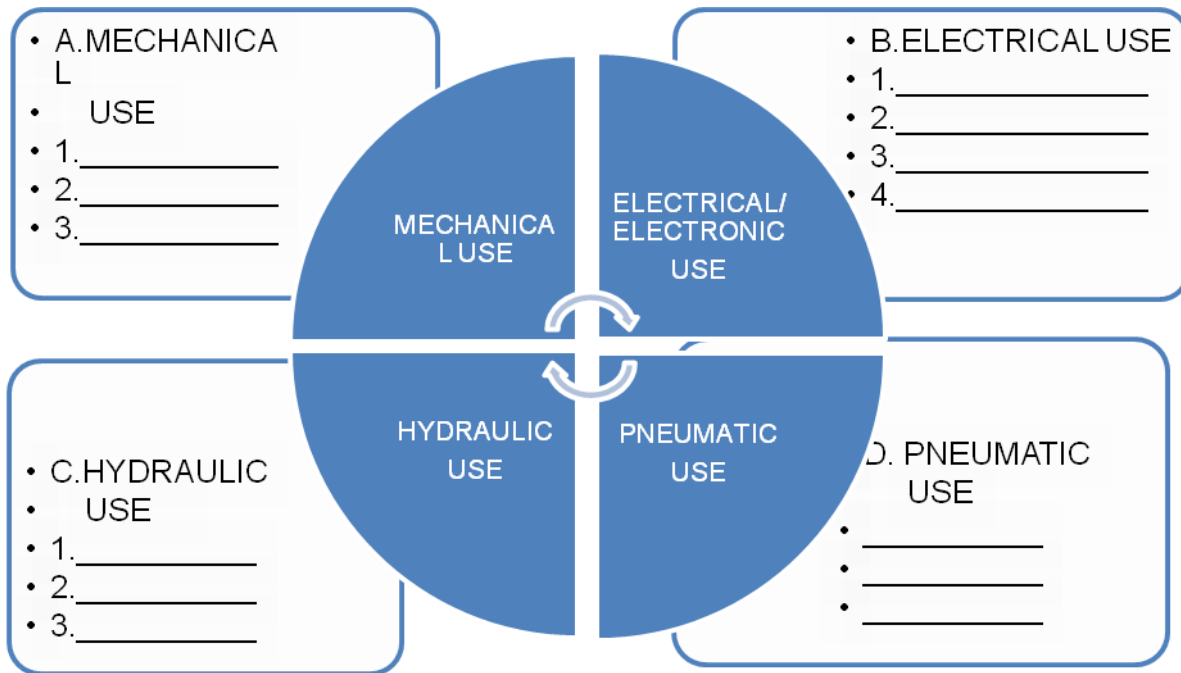

III. **Directions:** Based on the results of the activity, what is your personal reflection on measuring the ignition coil resistance using a V.O.M? Write your answer in your Activity Notebook.

1. What went right? _____

2. What went wrong? _____

3. What should be done? _____

Refer to the Answer Key. What is your score?



How Do You Apply What You Have Learned?

Show that you learned something by doing this activity

Operation Sheet 1.1

Title of Job: Measure the Ignition Coil Resistance Using a V.O.M.

Objective : The student will independently measure the ignition coil resistance using a V.O.M.

Materials Required: Ignition coil

Tools and Equipment needed: Bench work, V.O.M. tester

Procedure:

1. Set the selector V.O.M. to appropriate resistance range for primary ignition coil then calibrate



2. Measure the resistance of the primary ignition coil then record the data.

3. Set the selector V.O.M. to appropriate resistance range for secondary ignition coil then calibrate.





4. Measure the resistance of the Secondary ignition coil then record the data.

5. Compare with the specifications manual and interpret the reading.

Specifications Manual

Primary - _____

Secondary - _____

Interpretation:

Good – Use the coil

Bad – Replace the
Ignition coil



How Well Did You Perform?

**Find out by accomplishing the Scoring Rubric honestly and sincerely.
Remember it is your learning at stake!**

Performance Rubrics

Criteria	5	3	1
Proficiency	Performs the task with competence and exceptional performance	Performs the task with competence and with standard performance	Performs the task with competence but below standard performance
Accuracy	Performs the task with no error	Performs the task with at least 1-2 errors	Performs the task with at least 3-5 errors
Completeness	Performs all the steps in sequence	Performs the task with at least 2-3 steps not met	Performs the task with at least 3-5 steps not met
Safety	Follows all the safety practices as set in the guidelines	Follows the safety practices with at least 1-2 safety measures not met	Follows the safety practices with at least 3-5 safety measures not met

TOTAL _____

RATING SCALE: (PL)	Points Earned (S)	Numerical Rating (PL)	Descriptive Rating
	21 – 25	91 - 100	Outstanding
	16 – 20	86 - 90	Very Good
	11 – 15	81 - 85	Good
	06 - 10	76 - 80	Fair
	01 - 05	71 - 75	Needs Improvement

WHAT IS YOUR SCORE? _____



How Do You Extend Your Learning?

Assignment Sheet 1.1

I. Directions: Answer the question in your activity sheet. Compute for torque and show the solution

1. A mechanic assembled the engine. He needed to tighten the bolts. He used a tool with 18 inches (in) long and applied a force of 5 pounds (lbs). What was the torque generated?

LEARNING OUTCOME 2

Maintain measuring instruments

PERFORMANCE STANDARDS

- Measuring instruments are calibrated, safely handled and cleaned before and after using in accordance with industry standards.
- Measuring instruments are kept in safe, dry place.
- Proper techniques in using precise instruments are performed according to manufacturer's standards.



Materials

- Instruction manual
- Micrometer/Vernier caliper
- Receipt of purchase
- Tool holster
- Torque wrench
- VOM tester or equivalent



What Do You Already Know?

Let us determine how much you already know about maintain measuring instrument. Take this test.

Pretest LO 2

Directions: Write your answers to the following questions in Column A and in Column B. Write your answers in your Activity Notebook.

CALIBRATION OF MEASURING INSTRUMENTS	SAFE HANDLING PROCEDURES AND CARE OF MEASURING INSTRUMENTS
A. Why measuring instruments get out of calibration?	B. Basic rules to consider in managing your measuring instruments.
1.	1.
2.	2.
3.	3.
4.	4.
5.	5.



What Do You Need To Know?

Read Information Sheet 2.1 very well then find out how much you can remember and how much you learned by doing Self-check.

Information Sheet 2.1

Safe handling procedures and care of measuring instruments

Every property must be taken care with concern. Like a good manager looking for the welfare of his duty can be compared to a person who is responsible in keeping his personal belongings. The same is true in handling your tools. Tools, like measuring instruments must be handled with great caution. Aside from their expensive cost and delicate use, they are also sensitive. Even a slight accidental bump can affect the calibration and internal parts especially those that are made of electronic.

To protect your measuring instruments from mishandling, safety procedures must be followed at all times to ensure freedom from risk of danger and threat of thieves.

The following are basic rules to consider in managing your measuring instruments.

1. Always keep your receipt of purchase. This is one way of ensuring your measuring tools of their warranty if something happens to your tools. This will give you a good exchange of a new one if manufacturer's defect is the cause of the defect.
2. Always follow safety instructions. The safety instructions in owner's manual will be your guiding information on what and what not to do with your instruments. This will assure you of the proper use and step-by-step procedures if calibration is needed.
3. Always match the type of job with your instruments. Matching of job with your instrument is important. Do not use your instrument if it is not intended for tough job.
4. Always handle your measuring instruments safely. Never use your tools to point at somebody or use for joke or play. Remember, measuring tools are expensive. If they accidentally fall, they may easily be damaged. Always use the tool holder. Like a careful lineman, a tool holster is always fastened in his waist to protect the instrument from falling.



How Much Have You Learned?

Self-Check 2.1

- I. **Directions:** Write your answers for the questions in Column A and in Column B. Write your answers in your activity notebook.

CALIBRATION OF MEASURING INSTRUMENTS	SAFE HANDLING PROCEDURES AND CARE OF MEASURING INSTRUMENTS
A. Why a measuring instruments get out of calibration?	B. Basic rules to consider in managing your measuring instruments.
1.	1.
2.	2.
3.	3.
4.	4.
5.	5.

- II. **Directions:** Adjust to Zero accuracy the V.O.M. tester in the following selector range:

1. R x 1 Ω
2. R x 10 Ω
3. R x 1k Ω
4. R x 10k Ω

Refer to the Answer Key. What is your score?



How Do You Apply What You Have Learned?

Show that you learned something by doing this activity

Activity Sheet 2.1

PERFORMANCE ASSESSMENT

Name: _____ Year & Section: _____

Course: _____ Time Allotment: _____

Module Title: _____ Grading Period: _____

Unit of Competency	Tasks	Date	Time		Score	Performance Level
			Begun	Finished		
Perform Mensuration and Calculations						
LO1 Select Measuring Instruments and Carry out measurement and Calculations	Select and use measuring tools					
LO2 Maintain Measuring Instruments	Clean and store measuring instruments					

Average: _____



How Well Did You Perform?

**Find out by accomplishing the Scoring Rubric honestly and sincerely.
Remember it is your learning at stake!**

Performance Rubrics

Criteria	5	3	1
Proficiency	Performs the task with competence and exceptional performance	Performs the task with competence and with standard performance	Performs the task with competence but below standard performance
Accuracy	Performs the task with no error	Performs the task with at least 1-2 errors	Performs the task with at least 3-5 errors
Completeness	Performs all the steps in sequence	Performs the task with at least 2-3 steps not met	Performs the task with at least 3-5 steps not met
Safety	Follows all the safety practices as set in the guidelines	Follows the safety practices with at least 1-2 safety measures not met	Follows the safety practices with at least 3-5 safety measures not met

TOTAL _____

RATING SCALE: (PL)	Points Earned (S)	Numerical Rating (PL)	Descriptive Rating
	21 - 25	91 - 100	Outstanding
	16 - 20	86 - 90	Very Good
	11 - 15	81 - 85	Good
	06 - 10	76 - 80	Fair
Improvement	01 - 05	71 - 75	Needs

WHAT IS YOUR SCORE? _____



How Do You Extend Your Learning?

Assignment Sheet 2.1

Directions: Surf internet and watch video or make research on the following:

1. Selecting and using measuring tools.
 - Torque wrench
 - Vernier and Micrometer calipers
 - Vacuum and Compression gauge
 - Engine analyzer

2. Cleaning and storing measuring tools.
 - Torque wrench
 - Vernier and Micrometer calipers
 - Vacuum and Compression gauge
 - Engine analyzer



Congratulations! You did a great job! Rest and relax a while then move on to the next lesson. Good luck!

REFERENCES

- Swing Crispin, Frederic, Dictionary of Technical TermsThe Bruce Publishing Co.: 1948.
- Chilton's Easy Car Care. Chilton Book Company. 3rd Ed. Chilton Way, Radnor, PA 19089
- Stockel, Martin W. Auto mechanics Fundamentals. The Goodheart – Willcox Company, Inc. 1978
- The Oxford Dictionary of Current English. New Revised Ed. Oxford University Press, 1998.
- Popular Mechanics Guide To Auto Basic Repair and Maintenance. Book Division The Hearst Corporation, New York, NY
- www.google.com.ph
- en.wikipedia.org

LESSON 3

Interpret Plans and Drawings

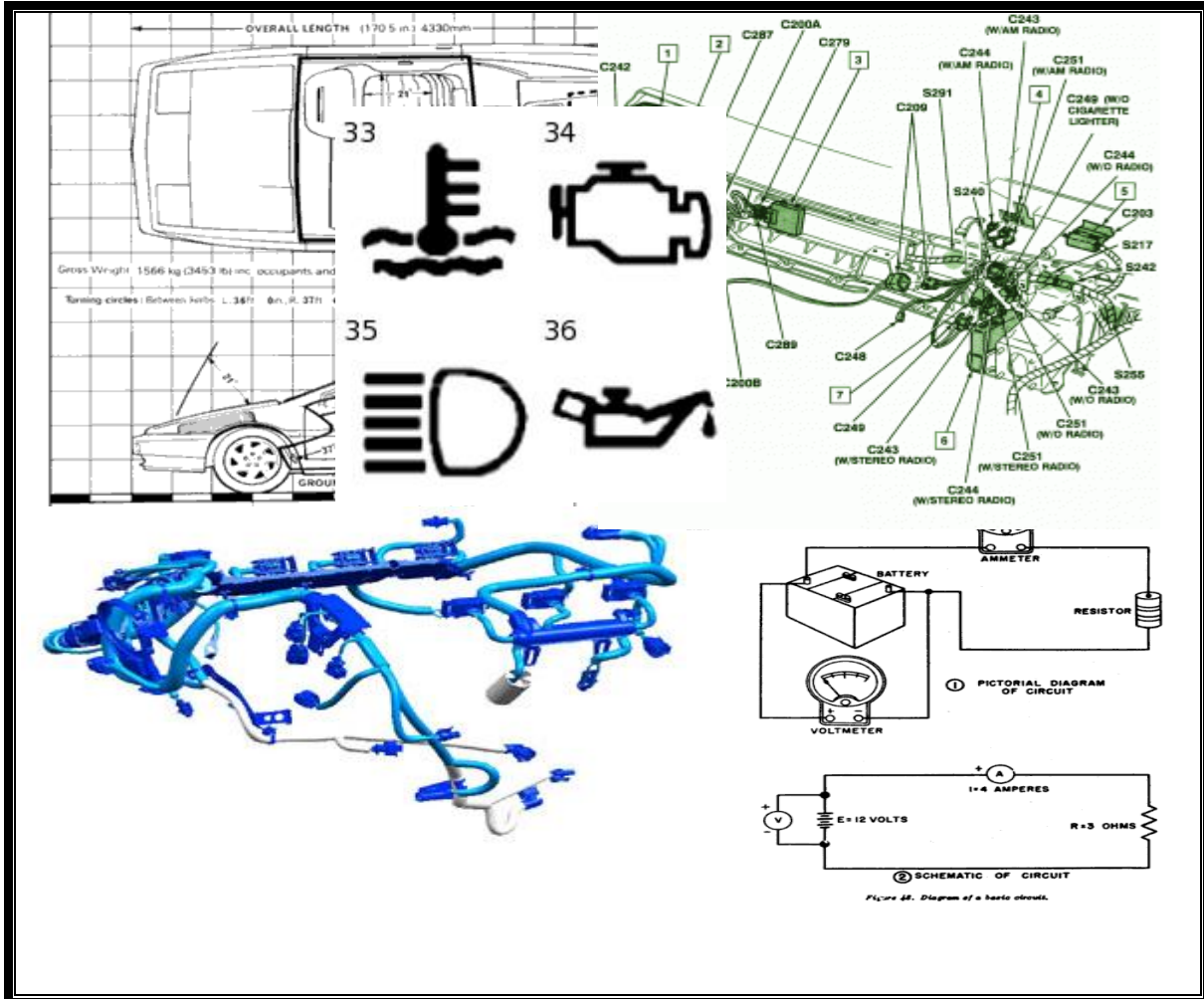

LEARNING OUTCOMES:

At the end of this Lesson, you are expected to do the following:

- LO 1. analyze signs, symbols and data; and
- LO 2. interpret technical drawings and plans.



Definition of Terms

ABS or Anti-lock Brake System - a safety system that allows the wheels on a motor vehicles to continue interacting with the road surfaces as directed by driver steering inputs while braking, preventing the wheels from locking up and therefore avoiding skidding

Airbag- a vehicle safety device. It is an occupant restraint consisting of a flexible envelope designed to inflate rapidly during an automobile collision

Cell - a device that produces electrical energy by the chemical action of electrodes in an electrolyte

Charging system - to generate enough current to keep the battery fully charged, and to satisfy the demands of ignition and electrical system and it includes the alternator, voltage regulator which often a part of the alternator itself, the battery and the indicator gauge or warning light on the dash

Current A flow of electric charge through a medium. This charge is a typically carried by moving electrons in a conductor such as wire

ECU or Engine Control Unit- a type of electronic control unit that controls a series of actuators on an internal combustion engine to ensure the optimum running

Electrical device - any physical entity in an electronics system used to affect the electrons or their associated fields in a desired manner consisted with the intended functions of the electronics components

Engine - a machine designed to convert energy into useful mechanical motion

Fabrication - an industrial term refers to building metal structure by cutting bending, and assembling

Fog beam - provide a wide, a bar shaped beam of light with a sharp cutoff at the top and are generally aimed and mounted low

Frame - a structural system that supports other components of a physical construction

Ignition Coil - an induction coil in an automobile's ignition system which transforms the batteries low voltage to the thousands of volts needed to create an electrical spark

Ignition- a spark in an internal-combustion engine that ignites and explodes a mixture of fuel and air

Information notice - a publicly displayed notice or board bearing directions, instructions, or warnings

Layout - the way component parts or individual items are arranged

Mandatory - needing to be done, followed, or complied with, usually because of an official

requirement.

Motorize- to fit something with motor: to fit something with a motor

Pavement- the layered structured that forms the surfaces of path, road, highway, or aircraft runway

Plans- drawing or diagram on a horizontal plane of the layout or arrangement

Power train - the portion of a vehicles drive mechanism that transmits power the engine to the wheels, tracks, or propellers

PPE or Personal Protective Equipment- the protective clothing, helmets, goggles, or other garments or equipment designed to protect the wearer's body from injury

Roundabout - a type of circular intersection, a junction in which road traffic flows in one direction around a central island

Schematic (diagram) - used extensively n repair manuals to help users understand the interconnections of parts, and to provide graphical instruction to assist in taking apart and rebuilding mechanical assemblies

Signage- any kind of visual graphics created to displays

Splice - to join two pieces of rope or wire by weaving the strands of each into the other

Symbol- written or printed sign or character (image) that can represents something in a specific context

Taillight- a part of lighting system of the vehicle usually mounted at the rear of the vehicles and usually come in pairs

Traffic signs or road signs - signs erected at the side of roads to provide information to road users

Transmission - it provides controlled applications of the power

Unification - the act of identifying two terms with a suitable substitution. the act or process of uniting or joining together

LEARNING OUTCOME 1

Analyze signs, symbols and data

PERFORMANCE STANDARDS

- Signs, symbols, and data are identified according to job specifications.
- Sign, symbols, data and abbreviations are determined according to classification or as appropriate in drawing.



Materials

- Traffic Signs - Safety signs and symbols
 - Warning signs
 - Regulatory signs- Mandatory and Prohibition
 - Information signs
 - Priority signs
- Road map
- Vehicle dashboard



What Do You Already Know?

Let us determine how much you already know about analyzing signs, symbols and data. Take this test.

Pretest LO 1

A. Directions: Encircle the letter of the correct answer.

1. Which sign represents “KEEP LEFT”?



2. Which sign represents “NO STOPPING”?



3. Among the signs which of these is categorized as WARNING sign?



4. Which one is an INFORMATIVE sign?



5. Which sign represents a “PEDESTRIAN CROSSING”?



6. Which of the following signs is indicating a high risk circumstances is present .



7. If you see this, , what should you do?

- A. Maintain speed and just go, because you have the right of way.
- B. Stop right away.
- C. Slow down or stop if necessary and wait until it's clear to go.
- D. Must turn right and always keep on the right side of the road.

8. Identify which is the opposite sign of. 



9. Categorize these signs , , , and 

- A. Mandatory
- B. Regulatory
- C. Warning
- D. information

10. Categorize these signs: , , and .

- A. Mandatory
- B. Regulatory
- C. Warning
- D. information

B. Directions: Write the letter of the correct answer on the space provided in each number.



- _____ 1. Indicates that one of the doors is not properly closed
- _____ 2. Charging system problem is detected
- _____ 3. The engine is experiencing low oil pressure.
- _____ 4. Excessive engine cooling system temperature.
- _____ 5. Hand brake is engaged.

Criteria for Evaluating Results of Pre-Test

100%-skip the Learning Outcome and proceed to the next Learning Outcome

99%-below – Go through the Learning Outcome









What Do You Need To Know?

Read Information Sheet 1.1 very well then find out how much you can remember and how much you learned by doing Self-check 1.1.

Information Sheet 1.1



Analyze Signs, Symbols And Data

Signs and Symbols are visuals that communicate idea, process or warning. Uses of signs and symbols are the following:

<p>1. Draw attention to health and safety hazards. In any place, preservation of life is the most important, whether it is in the workplace or on the road for both the worker and visitors alike.</p>	
<p>2. Point out hazards that may not be obvious. Extra precautions are reminded at some places or instances to avoid some risks that may not be obvious.</p>	
<p>3. For poor observance of proper use of equipments. Tools and equipments are designed for some specific purpose and proper use, keep in mind that these tools and equipments may not perform well and may fail or even break when not properly used. A single failure of equipments will result to decreased productivity. Even worst may cause harm to a worker himself.</p>	
<p>4. Provide general information and directions. In a workplace, signages provide information of the different tools and equipments' location as well as emergency exits.</p>	
<p>5. Remind employees where and when personal protective equipment must be worn. Workers sometimes forget to wear personal protective equipments though it is part of their daily routine.</p>	
<p>6. Show where emergency equipment is located. Though safety is observed and accident-free environment is monitored. Workers should be familiarized with the emergency equipments location and how to use it.</p>	
<p>7. Indicate where certain actions are prohibited. Certain actions are restricted in some equipment because of very high potential to cause injury.</p>	

Basic Sign Categories



Regulatory signs are symbols in *circle* intended to instruct on what one must do (or not do) under a given circumstance. It is also used to reinforce laws, regulations or requirements which apply either at all times or at specific times or places. Ignoring these signs may result to a violation of existing law or regulation.

<p>Prohibition: Safety signs with a <i>black symbol with a white background inside a red circle with a red diagonal line across the circle</i>. Used to state actions, dress or machinery which must not or should be used.</p>	
<p>Mandatory: Safety signs with a <i>white symbol in a blue circle</i>. Indicate actions, dress or precautions which must be used.</p>	



Implementing agency may apply penalties when regulatory signs are disregarded.

Warning: Used to warn the public of a hazard or mark a hazardous site or area. Also of actions or potential situations which could lead to danger.

<p>Caution: Indicates a potential hazard, which is a low level risk that could lead to minor or moderate injury. (Black on yellow)</p>	
<p>Danger: Indicates a definite hazard, which is a high level risk that could result in death or serious injury. (White on red)</p>	



Warning signs are best used to show unnoticeable hazards

Information: This sign is a very legibly printed and very noticeable placard that informs people of the purpose of an object, or gives them instruction on the use of something.











<p>Emergency: Indicates first aid, health, fire protection and emergency equipment (White on green).</p>	
---	---











General Information – Indicates permission or public information (White on blue).























Is it really necessary to use specific color and background for each group of signs?

Common Safety Signs

Information Signs				
				
FIRST AID EQUIPMENT	GENERAL WATER TAP	FIRE EXIT	STAIRS GOING UP	INFORMATION
				
MANNED FIRST-AID STATION	MAIN ELECTRICAL SWITCH	EMERGENCY STOP	ACCESSIBLE	TELEPHONE

Warning Signs				
				
CORROSION HAZARD	HIGH VOLTAGE	FLAMMABLE MATERIAL	TIP HAZARD	INDUSTRIAL VEHICLE
				
SLIPPERY FLOOR	DANGER HIGH VOLTAGE	DANGER FUEL STORAGE NO SMOKING	RISK OF FALLING	TOXIC MATERIAL

Regulatory - Mandatory Signs				
				
WEAR EYE PROTECTION	KEEP AREA CLEAN	WEAR HAND PROTECTION	LIFT CORRECTLY	WEAR FACE SHIELD
				
SWITCH OFF WHEN NOT IN USE	WEAR FOOT PROTECTION	WEAR PROTECTIVE CLOTHING	WEAR FOOT AND LEG PROTECTION	POSITION GUARDS BEFORE STARTING

Regulatory – Prohibition Signs				
				
SMOKING PROHIBITED	NO ENTRY	DO NOT TOUCH	NO EATING OR DRINKING	LITTERING PROHIBITED
				
ALCOHOL PROHIBITED	USE OF MOBILE PHONE PROHIBITED	OPEN FLAMES PROHIBITED	COMPRESSED AIR NOT FOR CLEANING	NO UNAUTHORIZED ENTRY



How Much Have You Learned?

Self-Check 1.1

Directions: Encircle the letter of the correct answer.

1. Signs and symbols provide information and direction in a workplace for easy access to the services or information. What is the required color and background used for these informative symbols?

A. White on Red

B. White on Blue

C. White on Black

2. Which is an example of informative sign?



3. Which is an example of sign that gives emphasis to hazards that is not obvious?



Signs with the symbol  is categorized as...

A. Mandatory sign

B. Prohibition sign

C. Caution sign

4. Signs in white color in a blue rectangular or square background is

A. Mandatory sign

B. Prohibition sign

C. Information sign

5. Signs enclosed in a triangle is

A. Regulatory sign

B. Warning sign

C. Information sign

6. Sign for "Warning: HOT SURFACE" is



7. It is a symbol which reinforces an existing law or order which, should never be ignored.



8. Which symbol is requiring the worker to use PPE?

A. Regulatory sign

B. Warning sign

C. Information sign

9. Which category of symbols is best used to show a health hazard that is not obviously seen?

A. Regulatory sign

B. Warning sign

C. Information sign

Refer to the Answer Key. What is your score?



How Do You Apply What You Have Learned?

Show that you have learned something by doing this activity.

Directions: On the space provided in the box, fill-up the blank with the correct answer and explain to the class your views about them.

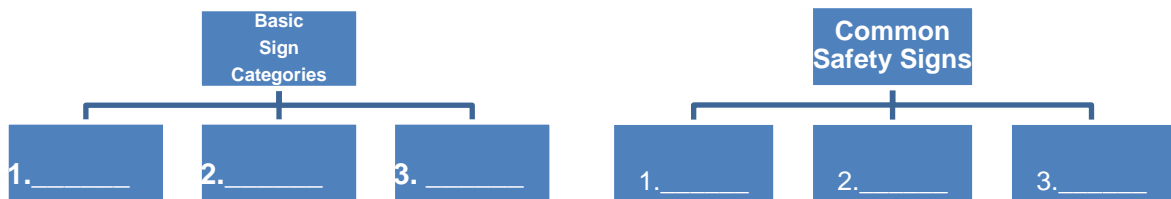



How Well Did You Perform?

Find out by accomplishing the following job. Remember it is your learning at stake!

Performance Rubrics

Criteria	3 (Better)	2 (Good)	1 (Needs Improvement)
Knowledge of the topic	<p>The topic was very satisfactory, clear and well-defined</p> <p>The main idea and major points were correctly stated</p>	<p>The topic was satisfactory, clear and defined</p> <p>The main idea was stated satisfactorily and some major points were all included</p>	<p>The topic was unclear and there was no main idea at all</p>
Delivery	<p>Presentation was completed on time, and the manner of speaking was steady throughout</p>	<p>Some corrections were needed to complete presentation on time and manner of speaking was neither too fast nor too slow</p>	<p>Presentation was not completed on time and manner of speaking was too fast or too slow</p>
Communication	<p>Spoke clearly and distinctively; and explanation of information was easily conveyed</p>	<p>Spoke clearly but explanations could be more detailed</p>	<p>Spoke unclearly with inadequate and incomplete explanation</p>
Completeness of information	<p>All the following information were included:</p> <ul style="list-style-type: none"> - technical issue - statement of the problem - conclusion - recommendations 	<p>Three (3) out of four (4) information were included:</p> <ul style="list-style-type: none"> - technical issue - statement of the problem - conclusion - recommendations 	<p>Only two(2) out of four (4) information were included:</p> <ul style="list-style-type: none"> - technical issue - statement of the problem - conclusion - recommendations

Rating Scale:

9 - 12 – Better

5 - 8 – Good

1 - 4 – Needs Improvement

WHAT IS YOUR SCORE? _____



How Do You Extend Your Learning?

Directions: Introduce yourself to the traffic police/aide as automotive servicing student. Interview him about the importance of traffic signs and symbols to the pedestrians.



What Do You Need To Know?

Read Information Sheet 1.2 very well then find out how much you can remember and how much you learned by doing the Self-check 1.2.















Information Sheet 1.2

Analyze Signs, Symbols And Data

Automotive servicing doesn't end on finishing the job in an auto repair shop. When necessary, a road test is performed to conduct a closer observation on a vehicle. To do this, the one who performs the job must be knowledgeable in driving, a holder of a driver's license and knows by heart the meaning of different traffic signs and symbols.

Traffic signs not just provide information but guide and keep safe the motorist and the community from accident.















Common Traffic Signs

Regulatory – Mandatory Signs				
White symbol on blue circular background				
				
TURN RIGHT	TURN LEFT	KEEP LEFT	AHEAD ONLY	KEEP RIGHT
Regulatory – Prohibition Signs				
Mostly black symbol on white circular background background with red border				
				
NO ENTRY	NO STOPPING	NO LEFT TURN	NO PARKING	NO U-TURN
				
SPEED LIMIT	NO OVERTAKING	NO RIGHT TURN	HORN	MOTORCYCLE PROHIBITED





The marking or figure in the SPEED LIMIT sign is in kilometer per hour

Warning Signs

Mostly black symbol on white triangular background with red border or
Black symbol in yellow diamond.

 BEND WARNING	 T-JUNCTION AHEAD	 TRAFFIC SIGNAL AHEAD	 JUNCTION AHEAD	 UNEVEN ROAD
 SERIES OF BENDS	 QUARYSIDE AHEAD	 STEEP HILL UPWARD	 SLIPPERY ROAD	 CHILDREN AHEAD
 PEDESTRIAN	 CROSSROAD AHEAD	 SHARP CURVE	 MERGING TRAFFIC	 TUNNEL AHEAD

For traffic signs, according to the “Vienna Convention on Road Signs and Signals”, the symbol in yellow diamond with black border is another warning sign in addition to the white triangle in red border.

Priority signs		
Other provision stated in the “Vienna Convention on Road Signs and Signals”		
YIELD or GIVE WAY SIGN	Inverted equilateral triangle in a white background with red border. It means you must let traffic in the intersection or close to it go first. Stop if necessary and go only when the way is clear.	
STOP SIGN	White text “STOP” in red octagon. It means you must come to a complete stop. Stop at the stop line if it is marked on the pavement. If there is no stop line, stop at the crosswalk. If there is no crosswalk, stop at the edge of the sidewalk. If there is no sidewalk, stop at the edge of the intersection. Wait until the way is clear before entering the intersection.	
PRIORITY ON ONCOMING	Priority on the traffic flow on the black arrow direction which gives them the “right of way”. While in red arrow direction must yield.	
PRIORITY FOR ONCOMING	Priority on the traffic flow on the white arrow direction, which has the privilege of the right of way, than in red arrow direction	

Information, Facilities or Service Signs are signs that use white symbol on blue or green rectangular background.

			
PARKING	PORT	HOSPITAL	HOME ZONE







For complete information on traffic signs please follow the link to:
[Vienna Convention on Road Signs and Signals at Wikipedia](http://en.wikipedia.org/wiki/Vienna_Convention_on_Road_Signs_and_Signals)
http://en.wikipedia.org/wiki/Vienna_Convention_on_Road_Signs_and_Signals







How Much Have You Learned?

Self-Check 1.2

A. **IDENTIFICATION:** Identify the symbol and write your answer on the space provided.

- 1.  _____
- 2.  _____
- 3.  _____
- 4.  _____
- 5.  _____

B. **CLASSIFICATION:** Put a check on the correct classification of the symbols given below.

- 1.  [] Regulatory [] Warning [] Information
- 2.  [] Regulatory [] Warning [] Information
- 3.  [] Regulatory [] Warning [] Information
- 4.  [] Regulatory [] Warning [] Information
- 5.  [] Regulatory [] Warning [] Information

Refer to the Answer Key. What is your score?



How Do You Apply What You Have Learned?

Show that you have learned something by doing this activity.

Activity Sheet 1.2

Hazard Reduction Road Plan

A. Designing a hazard reduction road plan.

1. Copy road map of your city or town.
2. Be sure to indicate the roads or streets on your map.
3. Place some landmarks.
4. Create 5 to 10 pieces small (about 1cm X 1cm) traffic and road sign
 - a. Use 1 or more regulatory sign.
 - b. Use 2 or more warning signs.
 - c. Use 1 or more information sign.
5. Based on your map, place your traffic and road signs on your map to keep it safe for the motorists and the community.

B. Answer the following questions

1. Where should you place your signs, left or right side of the road?
2. Why do you have to place your signs distance ahead of the actual location of its information?
3. What would happen if signs are not properly placed?
4. If you are to work in a large shop without any signs and symbol, what are the possibilities that might happen to you, shop and the job?



How Well Did You Perform?

Find out by accomplishing the following job. Remember it is your learning at stake!

Performance Rubrics

Criteria	3 (Better)	2 (Good)	1 (Needs Improvement)
Accuracy of information	All information were clear with no questionable ideas	Two (2) information were unclear/questionable	Three (3) or more information were unclear/questionable
Evidence of understanding	Demonstrated a clear and complete understanding of information	Demonstrated a good understanding of the information	Inadequate and incomplete information indicating poor understanding
Variety of information	Have wide variety of information with few repetitions	Have a few variety of information with some repetitions	Have little or no variety of information with lots of repetitions

Rating Scale:

9 - 12 – Better

5 - 8 – Good

1 - 4 – Needs Improvement

WHAT IS YOUR SCORE? _____



How Do You Extend Your Learning?

Directions: Move around your nearest barangay. Observe the visibility of traffic signs and symbols in the community. Report your findings in the class.



What Do You Need To Know?

Read Information Sheet 4.1 very well then find out how much you can remember and how much you learned by doing the Self-check 4.1.

Information Sheet 1.3









DASHBOARD SYMBOLS





The dashboard, particularly the instrument panel, represents the easiest way a vehicle talks back to its driver, allowing him to stay up to date with the status of the car and provide him with prior notice on potential mechanical problems.



Common Dashboard symbols and meaning.

 <p>ABS warning light</p>	<p>It is turned on every time there's something wrong with the Anti-lock Brake System. Note that the ABS symbol is activated once the driver starts the engine but it's automatically turned off after a few seconds.</p>
--	---

 Low fuel notification	This panel is switched on if the fuel level gets very low and refuel is required.
 Seat belt reminder	The symbol appears and remains active as long as the engine is started and the seat belt remains unfastened; depending on the car manufacturer and car model, the seat belt reminder is combined with an audio notification.
 Brake system alert	The notification is powered on if the ECU detects a problem to the brake system
 Tire pressure monitor	The warning is turned on in case of low tire pressure which could raise the fuel consumption or affect the grip.
 Front airbag	The light monitors the front airbag and, in case it is turned on, signals a problem with it; it usually requires professional assistance.
 Fog beams indicator	It is activated and remains on once the driver turns on the fog beams
 Battery warning	If this light is turned on while driving, it reveals a malfunction concerning the battery charging system.
 Emergency indicator	The notification is activated once the driver pushes the emergency button
 Power train malfunction	If on, this light shows that the power train has been damaged and the car needs to be serviced as soon as possible.

 Open doors indicator	This symbol is usually turned on just after the driver starts the engine and informs him that one or more doors are closed incorrectly
 Temperature warning light	It warns the driver of the possibility of engine overheating and usually demands the driver to stop the vehicle
 High beam light	It is turned on once the driver activates the high beam mode of the headlights.
 Oil pressure warning	This notification is turned on if the ECU detects a problem with the oil pressure; the driver is usually recommended to stop the vehicle and service it as soon as possible.
 Turn signals	Surely the most known instrument panels, the turn signals are activated once the driver changes direction and uses the signal lever



Follow the link to learn how to read dashboard instrument gauges:
<http://www.familycar.com/Classroom/dashboard.htm>



How Much Have You Learned?

Self-Check 1.3

Directions: Encircle the letter of the correct option for each given condition.

A.

1. Not charging



- A. B. C. D.

2. Over heating



- A. B. C. D.

3. Running out of gas



- A. B. C. D.

4. High beam on





- A. B. C. D.

5. Emergency indicator



- A. B. C. D.

B. **Multiple Choice:** Write the letter of your answer to identify the signs and symbols.

<p>1. This symbol lit up as soon as the ignition key is switch on then, later after the engine runs it lit off.</p>		<p>A. Charging system is normal and functional. B. Charging system needs repair C. Ignition system is malfunctioning D. Ignition system is normal and functional.</p>
<p>2. If this symbol is ignored</p>		<p>A. The engine will last long. B. The engine is overheating. C. Transmission gear oil is too low. D. This could lead to damaging wear and tear of the engine bearing.</p>
<p>3. When both of these are blinking up</p>		<p>A. Left turn or right turn lever jammed B. Emergency button has been activated C. Turn signal experiencing short circuit D. It's a parking light.</p>
<p>4. The ignition key is on and the seat belt warnig does no lit up even though not fastened correctly</p>		<p>A. Driver is not on the steering wheel B. Hand brake is activated. C. The engine has not started yet D. It will lit up when fastened correctly</p>
<p>5. Tire pressure monitor lit up</p>		<p>A. The tire is over pressurized. B. The tire is under pressure. C. All of the above D. None of the above</p>

Refer to the Answer Key. What is your score?



How Do You Apply What You Have Learned?

Show that you have learned something by doing this activity.

“GIVE ME A SIGN”

Where else are the warning signs? Have you seen all warning signs inside your shop? Can you now identify road signs and their meanings?

Here are some more signs and symbols to learn. Never drive if you don't know these, you might get into a trouble. Service mechanic should know these signs and symbols very well, these help a lot in diagnosing a problem.

Are you ready to meet your new set of signs and symbols? If yes,

1. Ready your paper and pencil.
2. Proceed to the nearest auto shop or garage (jeepneys are not recommended, cars are recommended).
3. Ask politely the owner for the assistance (never do this on your own), to turn on the ignition. See and observe the front panel in front of the driver's seat.
4. You must be seeing some symbols that lit-up in the front panel instrument. On your paper, draw those symbols that you have observed. It is an advantage if you can take a picture of it.
4. You may ask the owner what are those symbols for? Take note of its purpose.

Answer the following questions.

1. Why is it necessary to have the front panel instrument?

2. What does the symbol that lit is trying to convey?

3. How will these symbols help you in performing diagnosis in that vehicle?



How Well Did You Perform?

Find out by accomplishing the Scoring Rubric honestly and sincerely.
Remember it is your learning at stake!

Performance Rubrics

Criteria	3 (Better)	2 (Good)	1 (Needs Improvement)
Mastery of the concept	Manifested a working knowledge of the concept with no error	Manifested some working knowledge of the concept with few errors	Manifested few working knowledge of the concept with many errors
Level of competence	Performed the skill/process accurately and automatically	Performed the skill/process accurately but not automatically	Performed the skill/process with significant errors and cannot actually do the skill/process
Level of confidence	Demonstrated the skills correctly and easily with confidence	Demonstrated the skills correctly but not easily	Demonstrated the skills but made some mistakes
Completeness of work	Demonstrated a level of completion at 100%	Demonstrated a level of completion at 85%	Demonstrated a level of completion at 65%

Rating Scale:

9 - 12 – Better

5 - 8 – Good

1 - 4 – Needs Improvement

WHAT IS YOUR SCORE? _____



How Do You Extend Your Learning?

1. Using the internet, download the different signs and symbols found on the dashboard panel of a vehicle.

LEARNING OUTCOME 2

Interpret Technical Drawings and Plans

PERFORMANCE STANDARDS

- Necessary tools, materials and equipment are identified according to the plan.
- Components, assemblies or objects are recognized.
- Dimensions and specifications are identified according to job requirements.



Materials

- Sample drawing
- Schematic diagram of electrical circuit
- Pictorial diagram of electrical circuit
- Wiring diagram of a vehicle
- Layout diagram
- Sample plan
- Technical drawing



What Do You Already Know?

Let us determine how much you already know about interpreting technical drawings and plans. Take this test.

Pretest LO 2

Directions: Encircle the best answer for each question.

1. An illustration of clutch system wherein each component is arranged in a manner of proper

assembly. This presentation is

- A. Pictorial B. Semi-schematic C. Schematic D. Plan

2. In the Ignition System Diagram wherein symbols and images are used to represent the components, what kind of diagram is drawn on this presentation?

- A. Pictorial B. Semi-schematic C. Schematic D. Plan

3. A presentation of the ignition system wherein all components are represented by simple images.

- A. Pictorial B. Semi-schematic C. Schematic D. Plan

4. It is a circuit protecting device that melts and cuts off a circuit. What is the symbol?

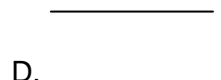
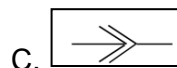
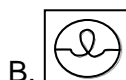

5. Which of the following is NOT used in schematic diagram?

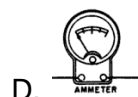
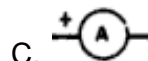
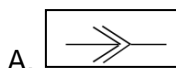

6. A picture of something made with a pencil or pen usually consisting of lines generally without color.

- A. Diagram B. Drawing C. Pictorial D. Plan

7. Uses simplified standard symbols.

- A. Layout Diagram B. Pictorial C. Semi-schematic D. Schematic

8. Also known as “Physical design” which shows the actual connection being used. This is more artistic than schematic and pictorial diagram.

- A. layout diagram B. pictorial C. semi-schematic D. schematic

9. Represents an electrical connection to the metal body or frame of the vehicle.

- A. Pictorial B. Plan C. ground D. Schematic

10. Used to present some components precisely with dimension.

- A. Plan B. Technical drawing C. semi-schematic D. pictorial

11. The source of electricity in an automobile.

- A. ground B. terminals C. fuse D. battery

12. Which of the following is considered as load?

- A. battery B. wire C. bulb D. ground

13. Electrically operated noise makers used by the driver to warn the pedestrian of an approaching vehicle.

- A. relay B. headlight C. horn D. tail light

14. An electrical device that converts electrical energy to mechanical energy in a rotary motion.

A. resistor

B. motor

C. relay

D. bulb

15. A device that allows a small current to control a switch of a much larger current circuit.

A. relay

B. engine

C. park light

D. switch

Criteria for Evaluating Results of Pre-Test

100%-skip the Learning Outcome and proceed to the next Learning Outcome

99%-below – Go through the Learning Outcome



What Do You Need To Know?

Read Information Sheet 2.1 very well; then, find out how much you can remember and how much you have learned by doing Self-check.

Information Sheet 2.1

DIAGRAMS, PLANS AND DRAWING

A **drawing** is a picture of something made with a pencil or pen usually consisting of lines generally without color. **Plan** is used to communicate fabrication instruction. A **diagram** is a “simple drawing” which uses a symbolic presentation of information according to some visualization technique. In automotive servicing, a graph-based diagram is commonly utilized in expressing information such as schematic, pictorial, semi-schematic, and a layout diagram.

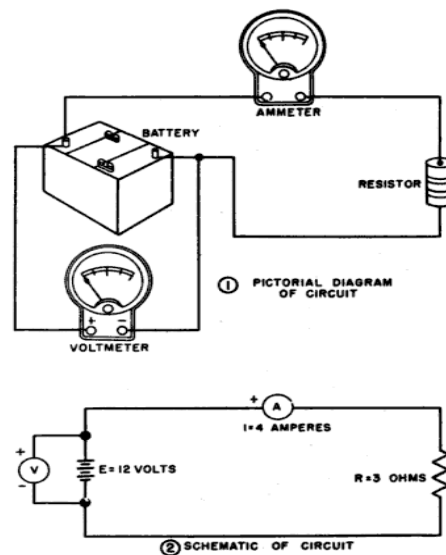

Common schematic diagrams

1. A pictorial diagram uses simple images of components,
2. A schematic diagram uses simplified standard symbols
3. A **semi-schematic** diagram combines some of the standard symbols with other elements displayed as simple images.

Observe that all lamps use standard symbols except the head light (sealed beam) which

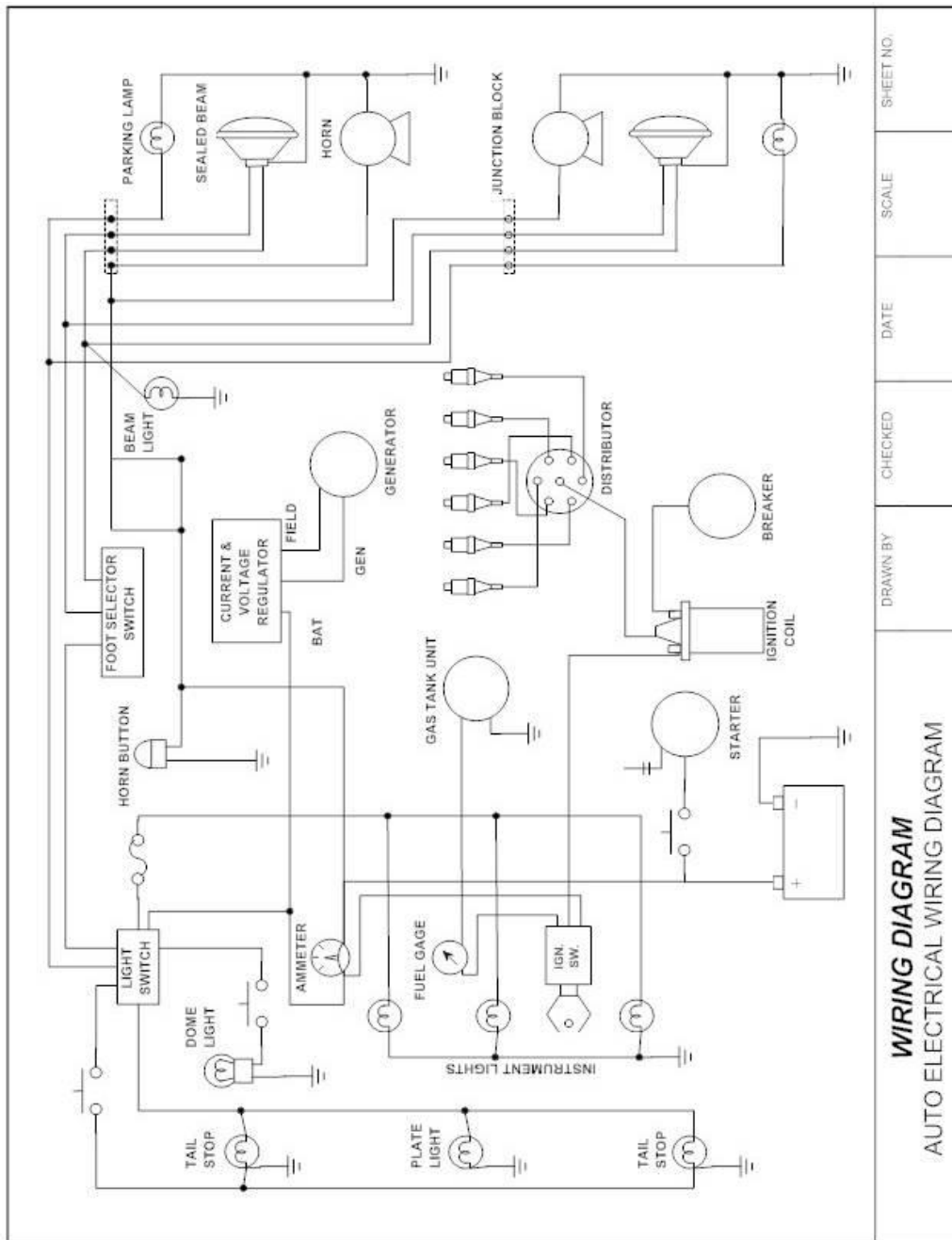

uses

an image. Spark plugs are displayed as images.



Advantage of the Semi-Schematic diagram in wiring diagram is making the diagram easy to realize than a pure standard symbol.

4. A **layout** diagram or the “physical design” which shows the actual connection being used. This is more artistic than schematic and pictorial diagram.

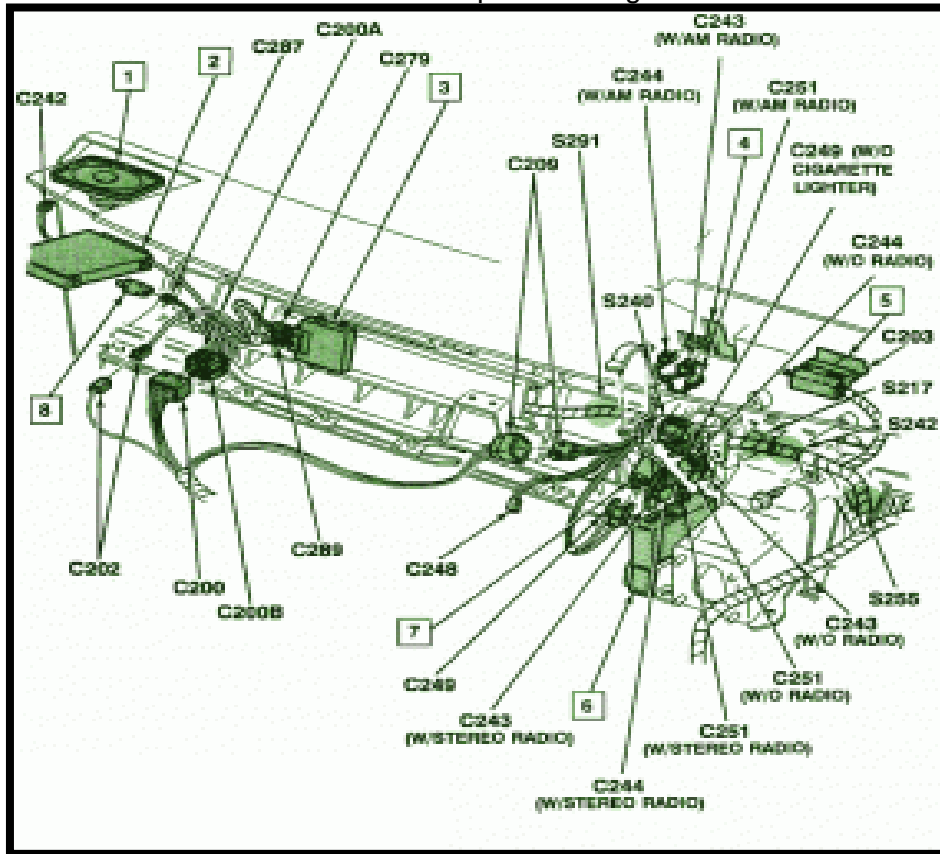

Plans are a set of drawings or two-dimensional diagrams used to describe a place or object, or to communicate building or fabrication instructions. The purpose of a plan is to capture all the geometric features of a component. This is also for presentation or orientation purposes.

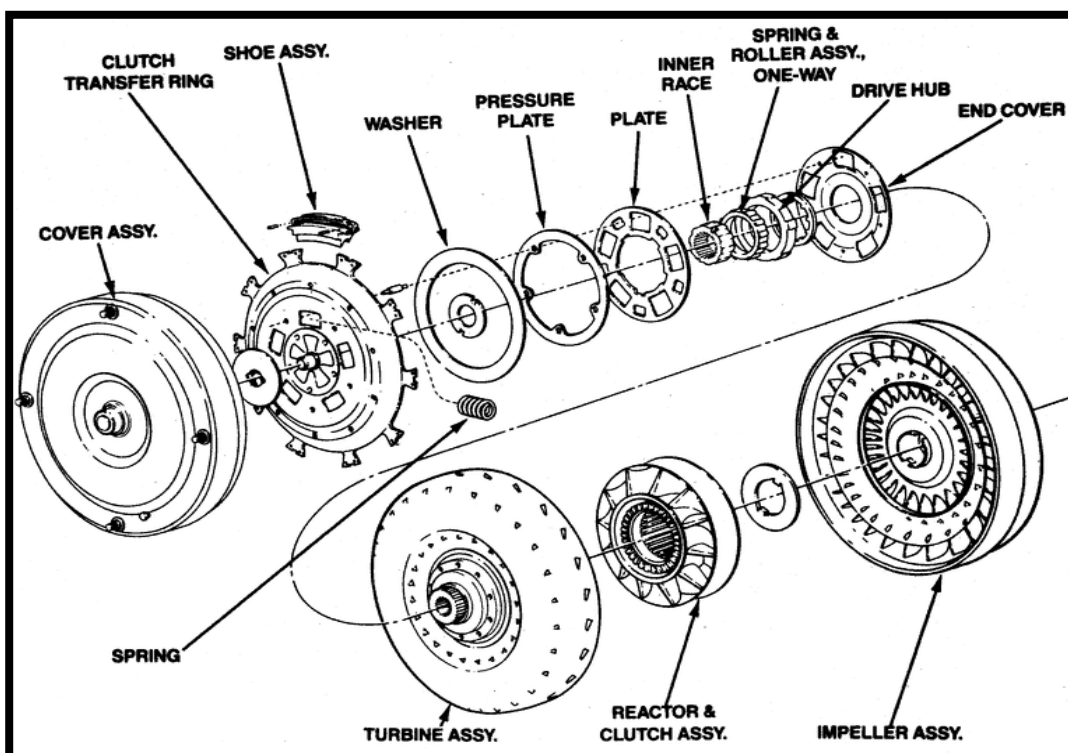

Common to industrial purposes like in automotive, a **technical drawing** is use to present some components precisely with dimension.

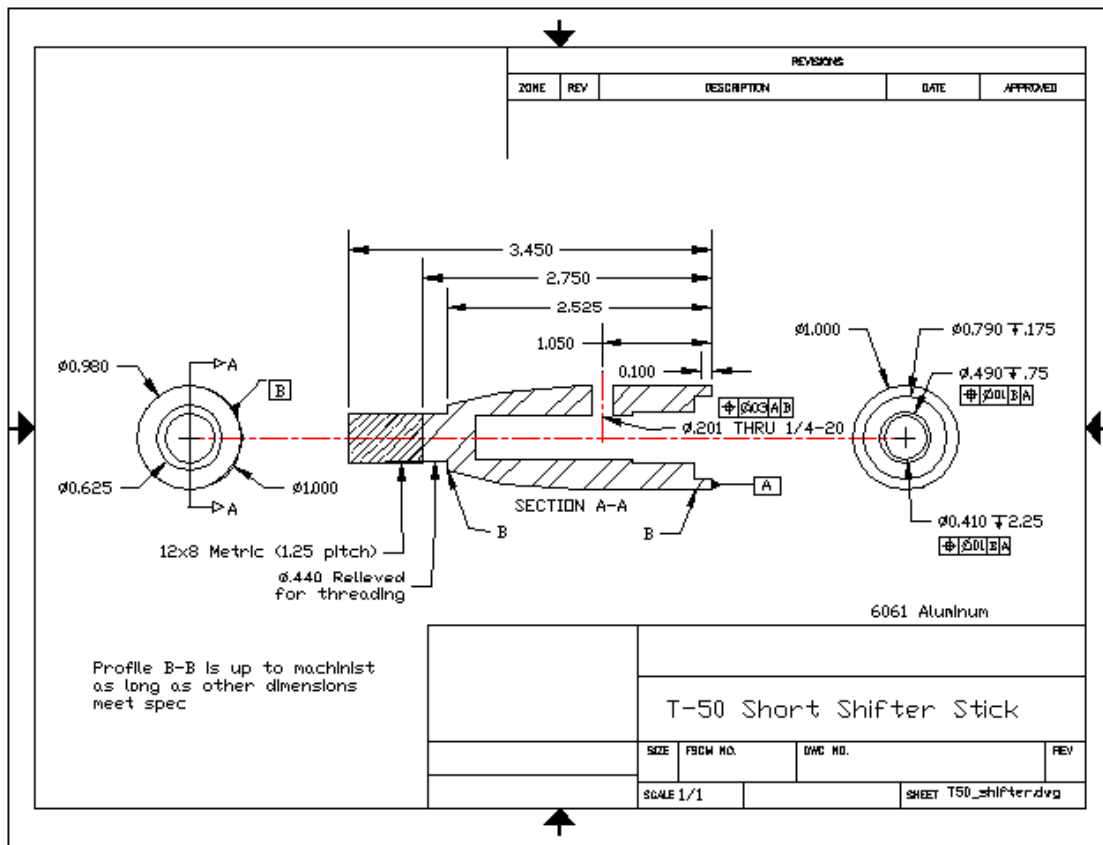

In this drawing, English System is used for all dimensions except the dimension for the thread given in “12x8 Metric (1.25 pitch)”.



Design specification is well illustrated in a technical drawing such those in times when necessary replacement has to be considered, the drawing will be the basis of requirement.

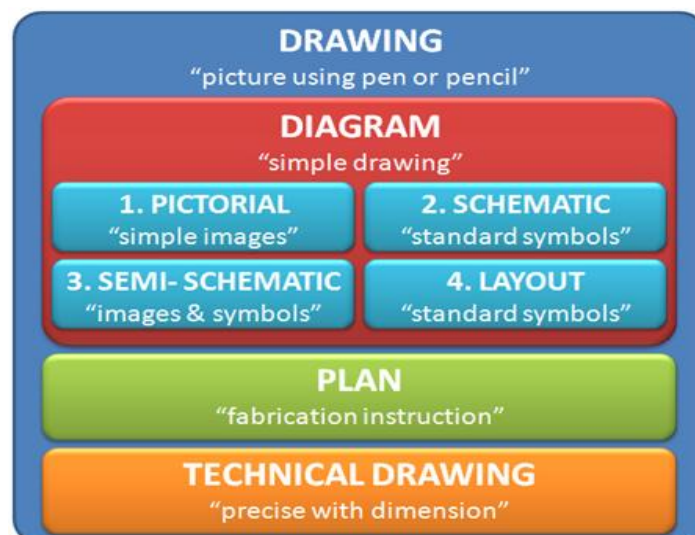



How Much Have You Learned?

Self-Check 2.1

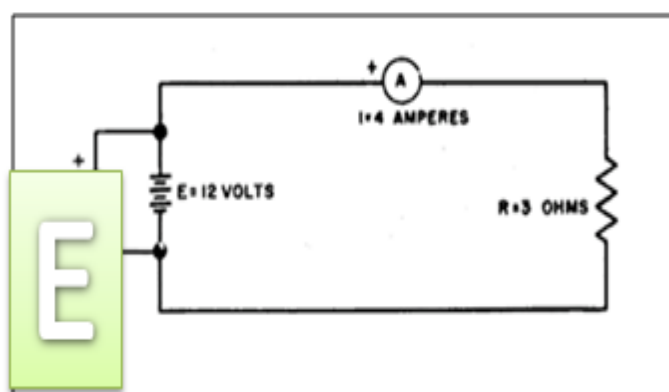
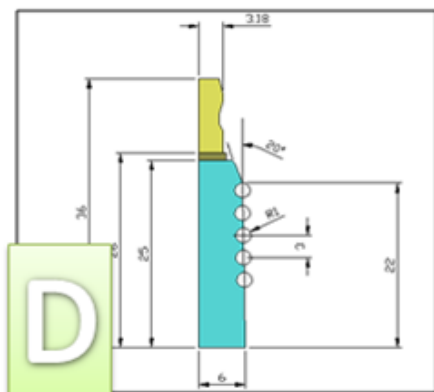
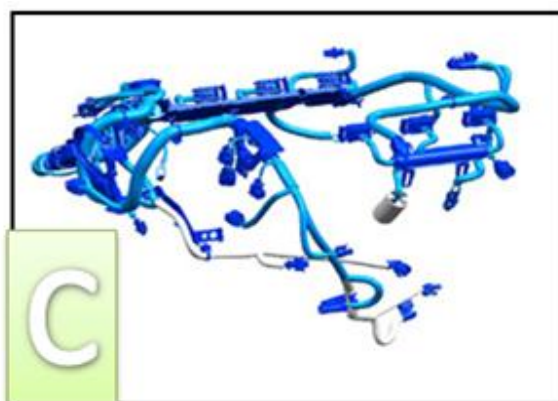
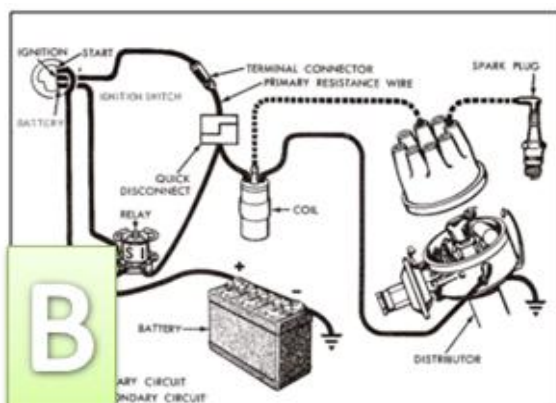
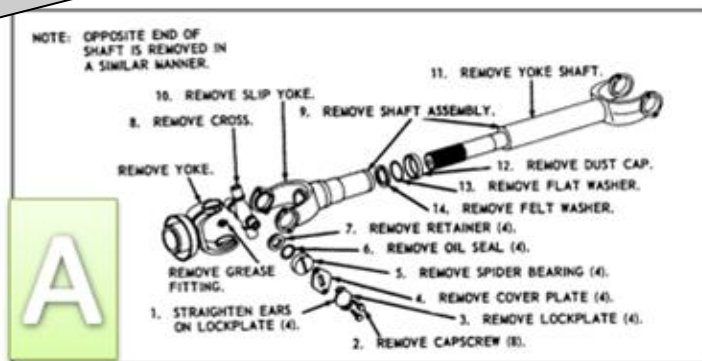

Directions: Write the letter of the correct answer for each number below.

1. Technical Drawing:

2. Schematic Diagram

3. Pictorial Diagram

4. Lay out Diagram

5. Drawing Plan

Refer to the Answer Key. What is your



What Do You Need To Know?

Read Information Sheet 2.2 very well; then, find out how much you can remember and how much you have learned by doing Self-check.

Information Sheet 2.2

COMMON ELECTRICAL SYMBOLS

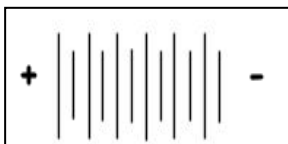

BATTERY. The pair of long and short lines represent a cell. A series of cells make up a battery. Long lines represent the positive plates while the

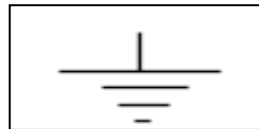

The **GROUND** symbol represents the electrical connection to the metal body or frame of the vehicle. In turn, the negative cable of the battery is connected between the negative battery terminal and the body/frame of the vehicle.



The **FUSE** is a circuit protection device. If the current exceeds the maximum rating for the circuit, the fuse element melts, thereby opening the circuit.

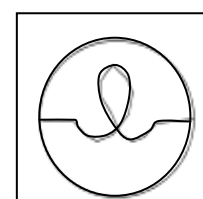

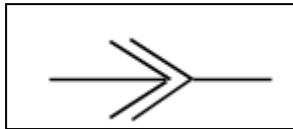

This symbol represents a **MALE-FEMALE CONNECTOR**. If it is a one piece multiple wire connector (harness), the connectors will be surrounded by a box.

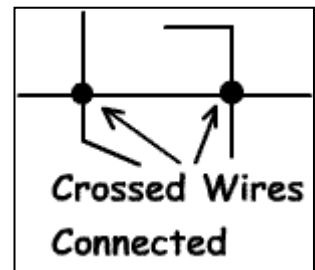
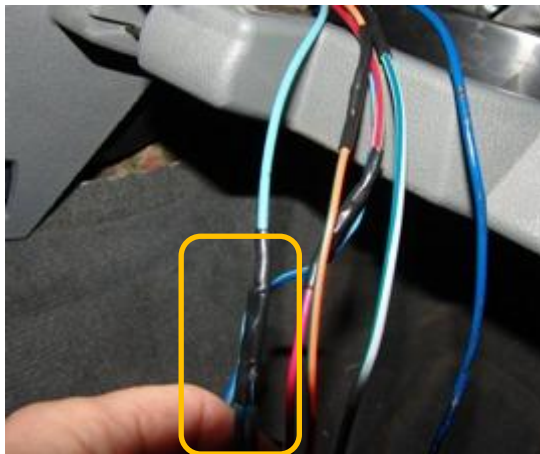
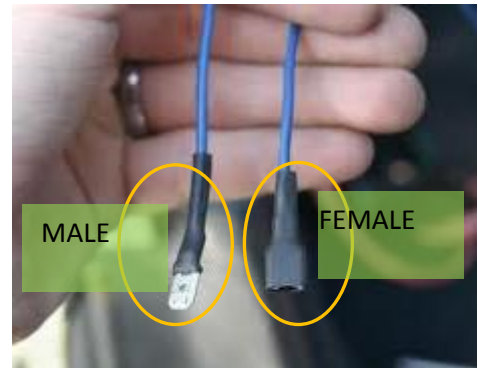

A dot at the intersection of wires is a permanent **CONNECTION** point, or splice

If there is no dot at the intersection of the lines, then those wires are not connected.

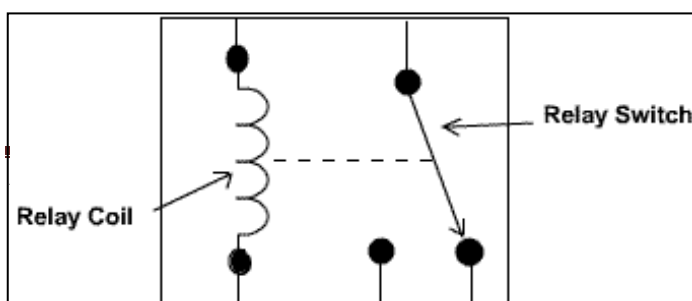
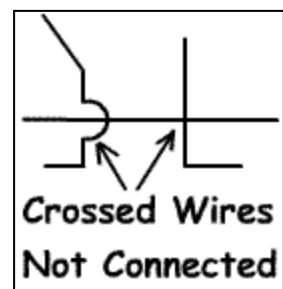

A **RELAY** is a device that allows a small current to control a switch of a much larger current circuit.



A fixed **RESISTOR** is an electrical device that is used to reduce current flow.

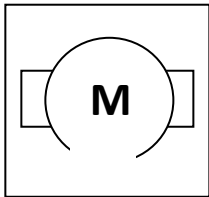

MOTOR is an electrical device that converts electrical energy to mechanical energy in a rotary motion

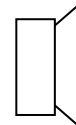

HORN is an electrical device that converts electrical energy into sound.

COMMON DRAWING SYMBOLS

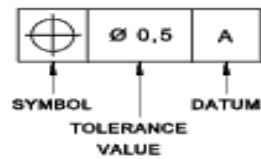

	STRAIGHTNESS		POSITION
	FLATNESS		SYMMETRY
	CIRCULARITY		PARALLELISM
	CYLINDRICITY		PERPENDICITY
	PROFILE OF LINE		ANGULARITY
	PROFILE OF SURFACE		RUN-OUT
	COAXIALITY		TOTAL RUN-OUT

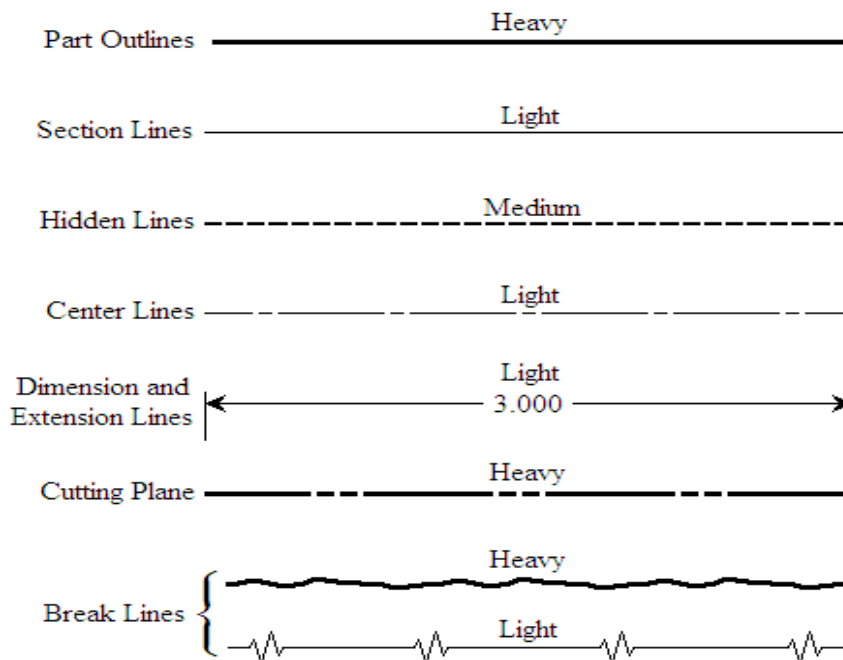





How Much Have You Learned?

Self-Check 2.2

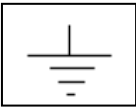
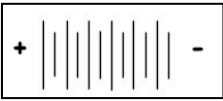
- A. **Directions:** Match Column A with Column B. Write only the letter of the correct answer on a separate sheet of paper.

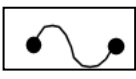
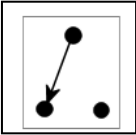
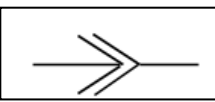
<p>1. It is a circuit protecting device which melts and opens a circuit when a current exceeds its maximum rating.</p> <p>2. Which symbol represents the connection of a load to the frame or body of the vehicle?</p> <p>3. What symbol is used to represent the source of electrical energy?</p> <p>4. Which symbol represents a device the opens and closes the circuit?</p> <p>5. Which symbol stands for joining pair of male and a female connector</p>	<p>A. </p> <p>B. </p> <p>C. </p> <p>D. </p> <p>E. </p> <p>F. </p>
---	---

Column A

Column B

B. Draw and Identify: Draw the missing symbol on the box and write the name of the symbol on the space provided.

1. _____

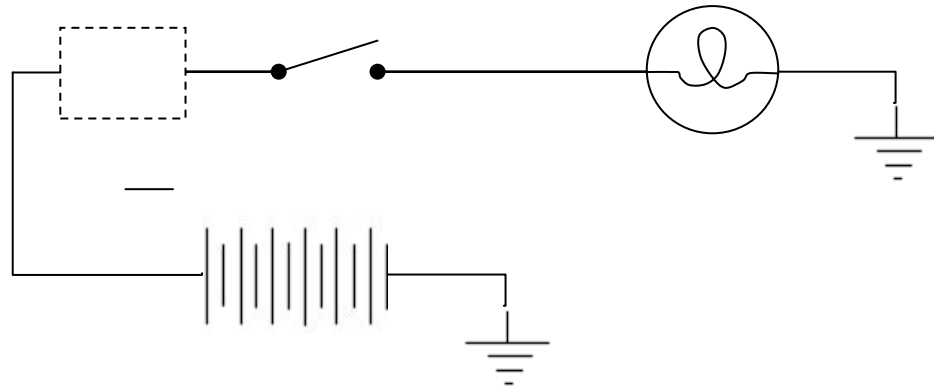

2. _____

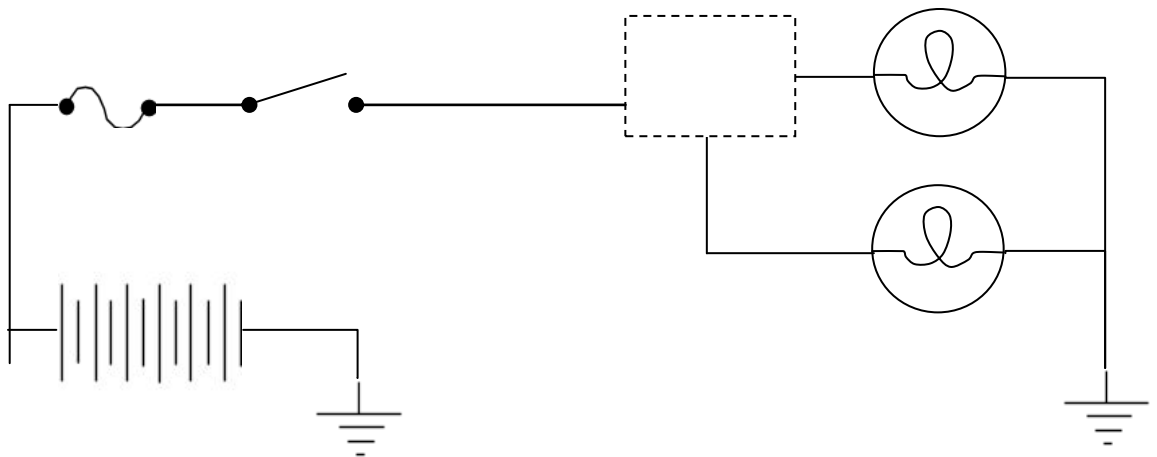

3. _____

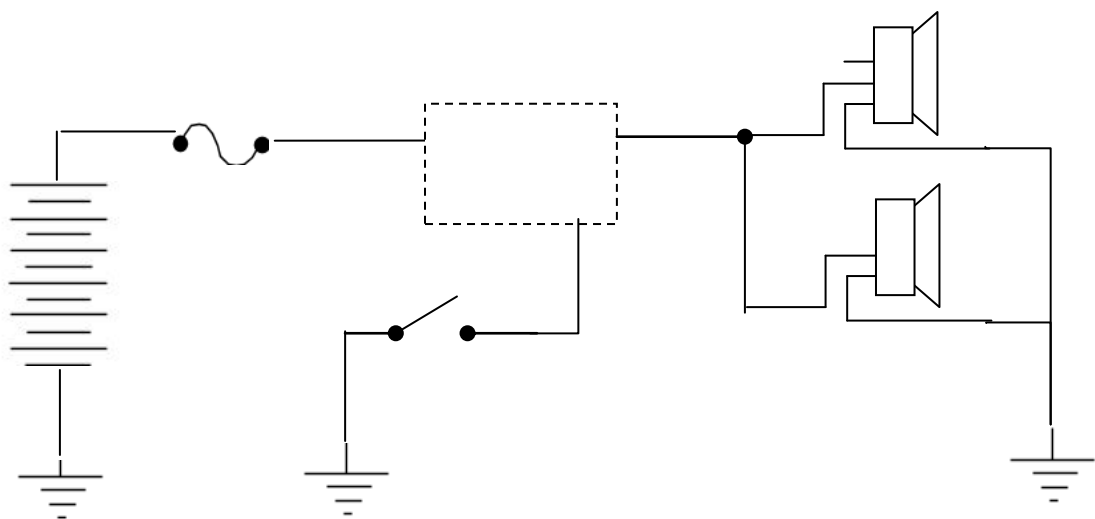

Refer to the Answer Key. What is your score?



How Do You Apply What You Have Learned?

Show that you learned something by doing this activity.

Activity Sheet 2.2

Directions: Answer the following question:

1. Since most component of a vehicle is readily available in the auto supply, explain why is it necessary for automotive servicing to have a technical drawing?

2. In technical drawing, explain why dosome components need to be sectioned?



How Well Did You Perform?

Find out by accomplishing the Scoring Rubric honestly and sincerely. Remember it is your learning at stake!

Performance Rubrics

Criteria	3 (Better)	2 (Good)	1 (Needs Improvement)
Knowledge of the topic	<p>The topic was very satisfactorily clear and well-defined</p> <p>The main idea and major points were correctly stated</p>	<p>The topic was satisfactorily clear and defined</p> <p>The main idea was stated satisfactorily and some major points were all included</p>	<p>The topic was unclear and there was no main idea at all</p>
Delivery	<p>Presentation was completed on time, and the manner of speaking was steady throughout</p>	<p>Some corrections were needed to complete presentation on time and manner of speaking was neither too fast nor too slow</p>	<p>Presentation was not completed on time and manner of speaking was too fast or too slow</p>
Communication	<p>Spoke clearly and distinctively; and explanation of</p> <p>Information was easily conveyed</p>	<p>Spoke clearly but explanations could be more detailed</p>	<p>Spoke unclearly with inadequate and incomplete explanation</p>
Completeness of information	<p>All the following information were included:</p> <ul style="list-style-type: none"> - technical issue - statement of the problem - conclusion - recommendations 	<p>Three (3) out of four (4) information were included:</p> <ul style="list-style-type: none"> - technical issue - statement of the problem - conclusion - recommendations 	<p>Only two(2) out of four (4) information were included:</p> <ul style="list-style-type: none"> - technical issue - statement of the problem - conclusion - recommendations

Rating Scale:

9 - 12 – Better

5 - 8 – Good

1 - 4 – Needs Improvement

WHAT IS YOUR SCORE? _____



How Do You Extend Your Learning?

1. Using the internet, download the common traffic and drawing symbols used in a vehicle.



Congratulations! You did a great job! Rest and relax a while then move on to the next lesson. Good luck!

REFERENCES

LO1

- Manual of Traffic Sign
<http://www.trafficsign.us/signshape.html>
- Transportation Engineering Philippines
<http://engineer-einjel.blogspot.com/2009/10/traffic-signs.html>
- Vienna Convention on Road Signs and Signals
http://en.wikipedia.org/wiki/Vienna_Convention_on_Road_Signs_and_Signals

LO 2

- Automotive Technology Studies
http://rsandas.com/P1_Session_2-1.html
- How to Read Dashboard Lights
<http://www.autoevolution.com/news/how-to-read-the-dashboard-lights-1370.html#image2>
- Picture Symbol
<http://dashboardsymbols.com/the-symbols/>
- Understanding your dashboard gauges
<http://www.familycar.com/Classroom/dashboard.htm>
- The Different Safety Signs and Symbols
<http://safetysignsandsymbols.com/>

LESSON 4

Perform Shop Maintenance



LEARNING OUTCOMES:

At the end of this Lesson, you are expected to do the following:

- LO 1. inspect/clean tools, materials and shop equipment;
- LO 2. store/arrange tools and shop equipment; and
- LO 3. dispose waste/used lubricant.

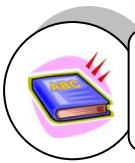

Definition of Terms

Apron-a garment for covering the front of the clothes

Automotivewaste- any harmful, discarded automotive byproducts

Cleaning- a process of removing dirt by wiping or by brushing

Corrosives - those chemicals that pose risk to organic material, especially human flesh.
Corrosive materials and most cleaners are composed of acids and bases

Coveralls- a protective clothing that provides full body protection

Flammable- a condition capable for easy combustion

Gloves- a rubber or leather-made hand protecting device

Goggles- a transparent or dark eyeglass that protect the welders' eyes from injury

Hand tools- portable devices that are guided and operated by hands

Hazardous material- any material that can cause bodily injury or pose a threat to the environment

Inspection- examining or looking closely as a course of action

Lubricant -a substance applied to a surface to reduce friction

Protection -prevention from being harmed or injured

Safety- freedom from danger or risk

Service procedures - an established method of work or task

Signs and symbols- a mark that expresses information to warn or to give direction

Toxic material- any poisonous material that can cause illness or death

Waste management- activities that deal with proper disposal of waste

Waste material -any discarded or unusable byproducts or materials

Workshop -a workplace where activities of service procedures are done

LEARNING OUTCOME 1

Inspect/clean tools, materials and shop equipment

PERFORMANCE STANDARDS

- Tools, equipment and work area are inspected and cleaned, free from dust, grease and other substance.
- Cleaning solvent as per workshop cleaning requirements is observed.
- Work area is checked and cleaned.



Materials

- Personal Protective Equipment
 - Goggles, welding mask, dust mask/respirator, hand gloves, coveralls
- Materials
- Rags, engine oil, diesel oil, gasoline , container, trash bin
 - Picture of safety signs and symbols
 - Sample chemicals/compound
 - Lacquer thinner. Paint remover, turco, acid, cleaners
 - Electric machines, connectors, plugs



What Do You Already Know?

Let us determine how much you already know about the inspecting/cleaning tools, materials and shop equipment. Take this test.

Pretest LO 1

Directions: Choose the letter of the option that will best complete the sentence.

- Accidents are usually caused by:
A. fate
B. mistakes
C. nature
D. haste
- Loose clothes, untucked shirt or unrolled sleeves worn during work by a mechanic may result to getting:
A. caught by the machine
B. dirty
C. torn
D. stained
- Type of shoes that should be worn as protection from accident or injury in the workplace:
A. hard shoes or boots with rubber soles
B. sandals with heels and closed toes
C. tennis shoes with Velcro fasteners
D. track shoes with laces
- Why rings or jewelry are dangerous to wear during work:
A. could cause electric shock
B. react chemically with oil and solvents
C. scratch machines or car finish
D. all of the above
- Most important reason why it's important to use the right tools for the right job.
A. save money
B. fun
C. efficiency
D. neatness



What Do You Need To Know?

Read Information Sheet 1.1 very well; then, find out how much you can remember and how much you have learned by doing Self-check.

Information Sheet 1.1

↑ WORKSHOP POLICIES AND SERVICE PROCEDURES



- **Workshop Policy**

The workshop policy applies to all workshop. It entails awareness about legal policies that must be put into practice. It is an understanding of all the hazards that may exist in the workplace. Each person who works at the shop should be required to read the policy and agrees to abide by it. This provides important legal protections in the event of an accident.

Workshop policy includes shop safety. It is the responsibility of everyone. Safety means protecting oneself from injury at all times. Working in the shop requires the use of a large variety of tools, materials, and equipment that can injure the worker and others in the shop if not properly used. A profitable auto shop is a well-run auto shop; a well-run auto shop is a safe one. Automotive mechanic uses power tools if needed, Power tools are usually electrically driven. It means it can work in a span of minute. Therefore, this must be treated with care and respect.

Workshop policy on service procedures from the time the customer comes in and gets out must be strictly followed so that they will be satisfied with the work rendered to them. Workers will also benefit if is obeyed. It means that they will work on the job order issued to them. They should never work on any other orders unless given to them by the person in charge so that healthy working relationship is preserved between the company and the workers.

There is also workshop policy on the use of tools, materials and equipment. Compliance with them will create good management of these implements. Materials like rags, petroleum products, and water are economized; tools hammers, wrenches and screwdrivers are taken care; and use of equipment like air compressor as substitute to electric fan is not misused. Aside from these, use of workshop and office facilities like fans, papers, toiletries, cleaning materials are not abused.

- **General Requirements of Safety in Workshop Policy**

- **Guidelines for safe practices.**

1. During the course of working in the shop, a general service technician moves from one area of the shop to another, moving parts and equipment around the shop and performing varied tasks. It is important that the shop floor be free of hazards that could cause technicians to slip or trip.
2. In a wide variety of shop tasks, waste materials are produced that can cause dangerous situations unless the waste materials are disposed of or stored properly.
3. Always be sure that shop exits are well-marked with an EXIT sign and are clear of obstructions.
4. For personal safety and to help keep the shop free of hazards, always comply with the following safety rules:
 - a. Work quietly and focus solely on the job at hand.
 - b. Do not leave creepers lay on the floor. Always stand them against the wall, wheels outward, when not in use.
 - c. Do not indulge in horseplay in the shop; immature and improper behavior can cause serious accidents.
 - d. Before performing a task, consider the relevant safety precautions related to the task and formulate a prevention plan for each hazard.
 - Keep the shop free of hazards.
 - Use appropriate personal protective devices (clothing and equipment)



- Handling and using materials containing potentially harmful chemicals correctly
- Use hand tools, power tools, and equipment correctly.

e. Always wear protective clothing and equipment in any situation where it is necessary.

- Wear protective eyewear at all times in the shop area.
- Do not wear rings, bracelets, watches, or necklaces when working around moving machinery or electrical equipment.
- Do not put sharp objects into the pocket of work clothes. They could cause personal injury or damage to vehicles.
- Keep hands free from oil and grease.
- Wipe off grease and other spills from the shop floor immediately, or at least put an oil-absorbing compound over them.



5. When cleaning up flammable liquids, always dispose of the rags in a metal container with a tight-fitting lid.
6. Do not look in the direction of another person who is welding.
7. Do not run a vehicle engine inside a closed garage unless the vehicle exhaust is hooked up to exhaust ventilation equipment. A deadly amount of carbon monoxide, which is present in the exhaust, can collect in a very short time.
8. Do not smoke in any shop, except in an area designated for smoking.
9. When pumping a flammable liquid from a large container into a small one, be sure to first attach a ground wire between both containers.



These guidelines for safety practices are practical in nature. Common sense dictates what to do but knowing how these practices are applied will increase awareness and ability to increase your competencies.

📌 STANDARD SAFE HANDLING OF TOOLS, MATERIALS AND EQUIPMENT

Safety in workshop is subject to a number of various risk assessments and safe codes of working practices. This must be adhered to and enforced by those in charge of the workplace. There may be risk activities in the shop by which one must observe properly.

• Handling of Tools, Materials, and Equipment

Everyone involve in the shop should be trained in proper handling of tools, materials, and equipment. It is necessary for you to recognize them and how they are used. The following information will give you insights on safe handling.

1. Service of records of all machine tools, materials and equipment must be kept. All information must be complete and done in order.
2. All portable electrical equipment must be regularly inspected and tested for electrical safety.
3. There must be a responsible person to take charge of the tools, materials, and equipment before, during and after used.
4. Every worker involved must be trained according to use of work equipment and tools.
5. Tools and equipment must be cleaned after use.
6. There must be proper uniform (apron, shirt, or apron) when working with machine tools or other equipment especially those that have rotating spindles.
7. Precision measuring equipment, drills, etc. must be placed in their appropriate cabinets after use.



Handling tools, materials and equipment safely will give a better work output. Their life cycle is prolonged. Task is accomplished easily and life is preserved.

📌 TYPES AND USAGE OF CLEANING CHEMICALS

Cleaning chemicals are used in taking away dirt, dust and hard to remove grime. Cleaning products have variety of ingredients. They may be safe or toxic depending on how they are used. Cleaning chemicals used in automotive servicing are quite different from the ones used in households. Even though some cleaning materials in households can have small amount of chemicals used in automotive, it cannot surpass the kind of cleaning materials used in automotive because of the different types and extent of their application.

Cleaning products for use in automotive is somehow stronger than other cleaning materials used for garments and other household purpose.

Cleaning products used in automotive are for plastics, metals, leathers, rubbers and glasses. These types of cleaning products are hazardous and corrosives. That is why, strict compliance with their use must be considered seriously or else this will pose danger to the one using these and to the environment. Cleaning products used for plastics are somehow not applicable for use in leathers because of some ingredients that do not conform to the latter.

The reason why they differ in types of chemicals mix in the product is the strength of alkalinity and acidity. **Strong alkalis** are those that have sodium hydroxide and are used in removing paints like paint remover. **Heavy-duty alkalis** are those that contains sodium carbonate and are used in removing greasy substance like thinner. A **mild alkali** is a sodium bicarbonate contained chemicals. They are also known as baking soda used in removing oily substance in automobile body before wash-out painting.

Aside from alkali type of cleaners, the **acid base type** cleaning chemicals have at least three types. The **strong acid cleaners** are highly corrosive. They are good in removing hard deposits. Hydrochloric acid or the well-known muriatic acid is a good example of this type. The **mild acid cleaners** are good in removing rusty stains and blemish. Anti-rust cleaners, wheels and tires dressing compound are good example of this type, and the **soft acid cleaners** are those that are used in cleaning glasses. This kind of cleaners is available in detergent, liquid, and bar.



Some manufacturers of cleaning products are producing all-purpose cleaners that can be used either in plastic, rubber or leather. This kind of cleaning materials are solvents that come in cream, paste or spray and can be applied directly to the article to be cleaned.



In using any cleaning materials for automotive use, it is basic and necessary that safety procedures must be followed. Usually, the use of appropriate hand gloves will protect the hands from entrance of chemicals to the skin and fingernails that may cause liver or kidney disease, skin irritation and allergy. Respirator or dust mask is also recommended to protect the respiratory system from inhalation of hazardous fumes. Fumes coming from chemicals can dry the eyes. That is why goggles is recommended in relieving the eyes from eye irritation, dryness and accidental splash of cleaning products. All protection must be done when using automotive cleaners to avoid risk of severe injury.





How Much Have You Learned?

Self-Check 1.1

I. Directions: Write the correct answer on the space provided in the statement. Use your Activity notebook in answering the statement.

- The workshop policy applies to all _____.
A. workshops
B. work spaces
C. work plan
D. work habit
- Workshop policy includes shop _____.
A. forum
B. recording
C. safety
D. shopping
- Workshop policy on service procedures must be strictly _____.
A, delayed
B. disallowed
C. followed
D. tried
- Always wear _____ clothing and personal equipment in any situation when necessary.
A. protective
B. deductive
C. impressive
D. inductive
- Workers should never work on any other orders unless given to them by the _____.
A. chairman
B. co-worker
C. person-in-charge
D. supervisor

II. Directions: Select the best answer. Write the letter only.

- Greasy and slippery tools must be _____.
_____ A. kept clean and free of dust and oil or grease.
_____ B. kept covered.
_____ C. used with gloves.
_____ D. wiped with friction oil.
- Defective tools and equipment should be _____.
_____ A. marked as defective
_____ B. put under the bench
_____ C. reused
_____ D. thrown away
- To prevent from being bumped into or tripped over, tools used should be _____.
_____ A. passed on to someone else who will need them next
_____ B. put under the bench so that they are out of the way
_____ C. returned to the tool room or put back in their drawers, cabinets or racks
_____ D. stacked neatly on the bench when you are done with them
- For safety, drawers and cabinet doors should be _____.
_____ A. avoided.
_____ B. clearly labeled.
_____ C. kept closed.
_____ D. painted red.
- Do not lay tools on ledges, fenders, or any place where they could _____.
_____ A. get lost.
_____ B. fall on someone.
_____ C. get dirty.
_____ D. look messy and unprofessional.

III. **Directions:** Identify the strength of the following chemical cleaners in the box. Write S for Strong, H for Heavy, M for Mild, and S for Soft. Write your answers in your Activity notebook.

1.

Paint Remover

1. _____

2.

Muriatic Acid

2. _____

3.

Lacquer Thinner

3. _____

4.

Dressing Compound

4. _____

5.

Glass Cleaners

5. _____

Refer to the Answer Key. What is your score?



How Do You Apply What You Have Learned?

Show that you have learned something by doing this activity.

I. **Directions:** Make a round inside the workshop area. Observe and list down the condition of the shop if it complies with the workshop policy requirements. Answer the following questions.

1. What workshop policy needs to be:

Improved	Removed

2. What other suggestions can you give?

2.1 _____

2.2 _____

2.3 _____

II. Directions: Perform the proper handling of tools, materials and equipment.

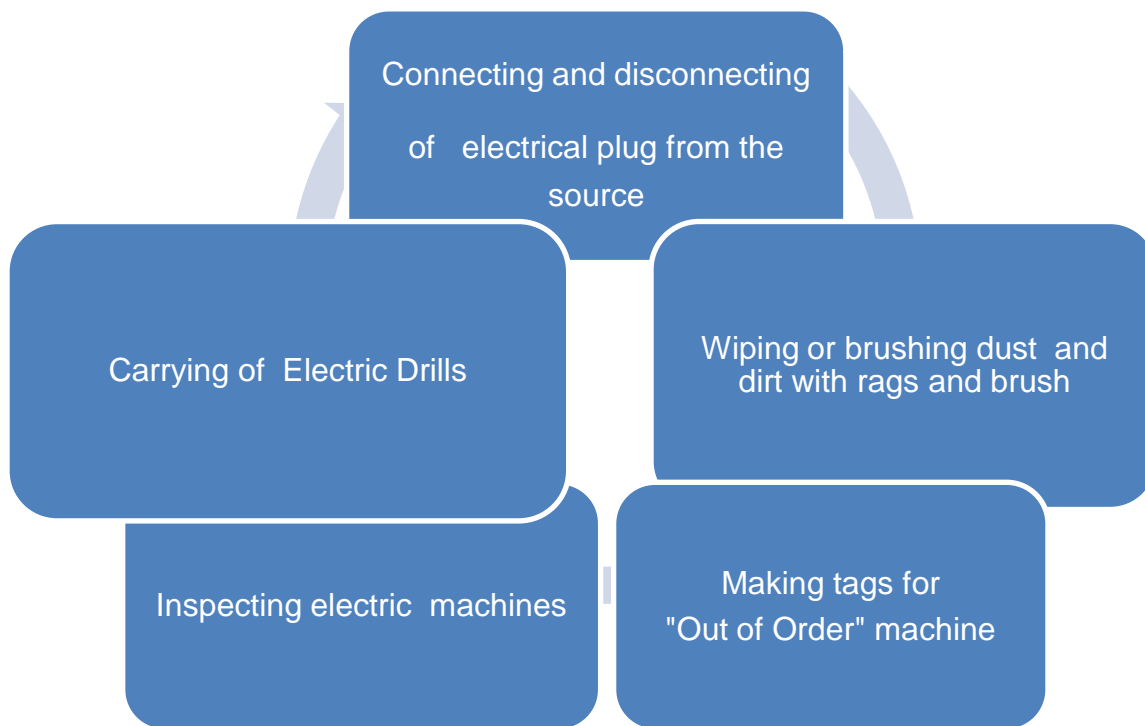



How Well Did You Perform?

Find out by accomplishing the Scoring Rubric honestly and sincerely.
Remember it is your learning at stake!

Performance Rubrics

Criteria	5	3	1
Proficiency	Performs the task with competence and exceptional performance	Performs the task with competence and with standard performance	Performs the task with competence but below standard performance
Accuracy	Performs the task with no error	Performs the task with at least 1-2 errors	Performs the task with at least 3-5 errors
Completeness	Performs all the steps in sequence	Performs the task with at least 2-3 steps not met	Performs the task with at least 3-5 steps not met
Safety	Follows all the safety practices as set in the guidelines	Follows the safety practices with at least 1-2 safety measures not met	Follows the safety practices with at least 3-5 safety measures not met

TOTAL _____

RATING SCALE: Points Earned (S)
Descriptive Rating (PL)

Numerical Rating (PL)

	21 – 25	91 - 100	Outstanding
	16 – 20	86 - 90	Very Good
	11 – 15	81 - 85	Good
06 - 10	76 - 80	Fair	
01 - 05	71 - 75	Needs Improvement	

WHAT IS YOUR SCORE? _____



How Do You Extend Your Learning?

Directions: Visit the nearest automotive shop in your community. Introduce yourself as automotive servicing student and ask for the different chemical cleaning materials they used in automotive shop. Compare with the ones listed below.

1. Anti-rust paint
2. Anti-rust spray
3. Automobile body cleaners
4. Baking soda
5. Glass cleaner
6. Lacquer thinner
7. Metal conditioner
8. Muriatic acid
9. Paint remover
10. Paint thinner
11. Solvent
12. Wheel and tire dressing compound

LEARNING OUTCOME 2

Store/arrange tools and shop equipment

PERFORMANCE STANDARDS

- Corresponding labels for containers and waste materials are posted and made visible.
- Total quality management is observable.



Materials

- Personal body protection
 - Bonnet, rubber gloves, apron, goggles, hand cream, safety shoes, coveralls
- International standard safety signs and symbols
- Picture of 5 S



What Do You Already Know?

Determine how much you already know about storing/arranging tools and shop equipment. Take this test.

Pretest LO 2

Directions: Write the letter of the best answer to complete the statement.

- To some degree, personal safety in the workshop is not only confined to the use of tools, materials and equipment but to _____.
A. her
B. him
C. others
D. self
- When working in the shop, it is a good personal protection to work in _____ area.
A. well-built
B. well-loved
C. well-scented
D. well-ventilated
- Goggles, head bonnet, and dust mask are good implements for _____ protection.
A. lower body
B. middle body
C. upper body
D. whole body
- Personal safety includes _____, values and awareness.
A. habits
B. vending
C. venture
D. ventilation
- When personal safety is the issue, it is basic to human instinct to _____ oneself.
A. prevent
B. produce
C. promote
D. protect
- High grade rubber _____ protects the hands from paint, solvent and electrical shock.
A. belt
B. band
C. gloves
D. tire
- The nose and face should be protected with _____.
A. face lift
B. face mask
C. face powder
D. scar face
- _____ and symbols must be clearly written and properly identified.
A. signs
B. insignia
C. stickers
D. posters
- International standard labeled signs are black _____ with red surround shape.
A. cymbals
B. samples
C. sandals
D. symbols
- When working _____ must come first before anything else.
A. personality
B. personal attributes
C. personal safety
D. personal share



What Do You Need To Know?

Read Information Sheet 2.1 very well. Then find out how much you can remember and how much you learned by doing Self-check.

Information Sheet 2.1

📌 PERSONAL SAFETY AND LABELING PROCEDURE

Whenever safety is the issue, safety of oneself usually comes to mind. It is a basic instinct for human being to protect himself.

Safety in the workshop is not only confined to the use of tools, materials and equipment. To some degree, in workshop, personal safety must come first before anything else. You can replace broken tools with new one. Buy new materials and operate new equipment but you cannot buy new body as replacement if something happens to it.

Personal safety involves habits, values, and awareness. Having these virtues will shy you away from injury and harm.

To be more specific, personal safety can be classified in different manners.

1. **Upper body protection.** These includes safety glass for eye protection called goggles . This is used when grinding metal or when reconditioning tools. Welding goggles are also used when joining metals so that eyes are protected from flying debris. Transparent goggles are useful when working underchassis. Eyes are protected from dust and small particles that may get into the eyes and cause irritation. The head should be protected with head gear like bonnet or cap. This head gear protects head and hair from dust, accumulated dirt , falling object and harmful chemical especially when working underneath the vehicle. The nose and face should be protected with face mask or respirator so that harmful fumes from exhaust gas and chemicals may not get into the lungs.



2. **Middle body protection.** These include apron that protects the body from dirt and sudden spill of substance like oil. High grade rubber gloves protect the hands from paint, solvent and electrical shock.. Leather gloves protect the hands from hot surface like newly welded metal to avoid abrasion. Hand cream is also useful to protect hands from dryness.



3. **Lower body protection.** These include safety shoes to protect the feet from slipping and risk from heavy falling object.



4. **Whole body protection.** The use of coveralls or jumpsuit is a good protection against flying debris, chemical spill, paint, solvent and abrasion.

Aside from the different implements to protect self from any harmful injury, labeling of warning signs and symbols must be clearly written and properly identified.

Labels must be color coded. Usually a red color code is a sign of danger sign. It gives you information on the seriousness of consequence if not followed. Yellow color code can mean warning. It gives information to forewarn you from danger. A green color code may mean safe. It is good that workplace be posted with properly labeled signs, symbols, and stickers.

International standard labeled signs are black symbol with red surround shape.



SIGNS AND SYMBOLS ARE IMPORTANT. USE THEM.

ISO/SEMI (Should be black symbol with red surround shape.)



ANSI (Can be black symbol and surround shape, or can use the format above.)



↑ PRINCIPLES OF TOTAL QUALITY MANAGEMENT (TQM) - 5 S

The total quality management in automotive servicing is getting the job done with excellence and direction. This is one of the principles that should be implemented in order for the management to work. One of the key principles is the proper maintenance of the shop. To be effective, there must be some methods to work on. One is the management of **peopleware**. They are the ones that need sustainable training in the shop and workshop environment. This increases their manpower capability in the field of work. Because of this, they become assets in managing the shop. Increasing their skills also increases their values and worth. Therefore, it decreases the chance of accidents and expenses in the workplace by applying corrective and preventive maintenance. These corrective and preventive measures also include the **hardware**. The hardware part of management in automotive servicing are the workshop facilities like the tools, materials, equipment/machineries including facilities like furniture, lighting, water, and furniture. Proper management of these hardware results in cost effective expenses in the workplace.

In Japan, they use the 5 S principles of management for increase efficiency and effectiveness in the workplace. These 5 S principles of management will help you a lot in sorting, setting in order/simplifying, sweeping, standardizing, and sustaining.

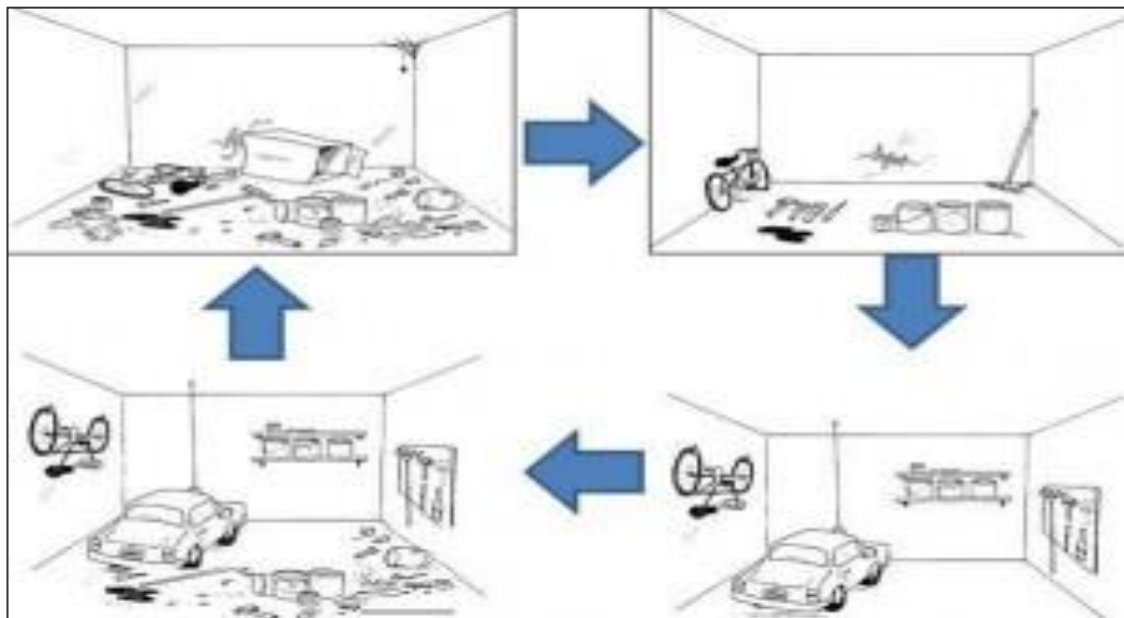

1. **Sorting** – a process of taking things that are needed and taking away those that are not needed anymore. In this way, eliminating unnecessary items gives more free space to those items that are needed. To be more specific, those items for disposal must be marked or tagged with appropriate color for easy identification. Sample guide questions:

- What items should be eliminated?
- What items should be retained?
- What items can be reconditioned/ repaired?

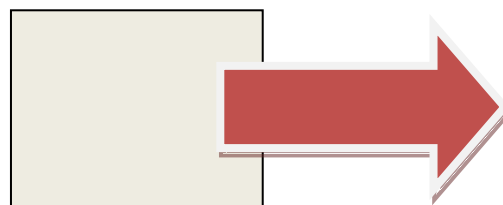

2. **Setting in order, Straightening, Simplifying** – a process of making things easy to see, easy to get and easy to return. Sample guide questions:

- Where is the tool, materials, and equipment located?
- What tools, materials, and equipment are common?
- Where is the best location for each of them to be placed?

Screwdrivers
 Philipps
 Standard
 Offset
 Stubby
 Allen

Oils
 Engine oil
 Gear oil
 Penetrating oil
 Automatic transmission oil
 Brake/Clutch fluids

Gaskets
 Overhauling gasket
 Carburator kit gasket
 Transmission gasket
 Differential gasket

3. **Sweeping, Shining, Systematic cleaning** – a process of clearing out the dirt, dust and residual grime to make the space, machines, and fixtures clean. Examples are:
- What location or machines need immediate and regular clean-up?
 - Which of them should be cleaned first?



process of having a uniform procedures of work or placement of things in proper place. Examples are:

- How the procedures done?
 - What is the schedule of work from start to finish?
 - Where should the finished work be placed?
 - Who will be in-charge of testing the work?
5. **Sustaining** - a process of maintaining a continuous and consistent implementation of doing the 5 S principles.

With these 5 S in mind as tool for management principles, it is expected that it can build a good workshop and workplace environment that in the process it will result in shop maintenance, efficiency and effectiveness.



How Much Have You Learned?

Self-check 2.1

I. Directions: Write the correct answer for each of the following questions:

- When personal safety is the issue, it is basic to human instinct to _____ oneself.
A. prevent
B. produce
C. promote
D. protect
- To some degree, personal safety in the workshop is not only confined to the use of tools, materials and equipment but to
A. her.
B. him.
C. others.
D. self.
- Personal safety includes _____, values and awareness.
A. habits
B. vending
C. venture
D. ventilation
- Goggles, head bonnet, and dust mask are good implements for _____ protection.
A. lower body
B. middle body
C. upper body
D. whole body
- When working in the shop, it is good personal protection to work in _____ area.
A. well-built
B. well-loved
C. well-scented
D. well-ventilated

II. Directions: Match Column A with Column B. Write the letter of the correct answer. Use your Activity notebook.

Column A	Column B
1. peopleware	A. These are the ones that need sustainable training in the shop and workshop environment.
2. Standardizing	B. Management of workshop facilities like the tools, materials, equipment / machineries including facilities like furniture, lighting, water, and furniture.
3. Hardware	C. Maintaining a continuous and consistent implementation of doing the 5 S.
4. Sustaining	D. Having uniform procedures of work or placement of things in proper place.
5. setting in order	E. Making things easy to see, easy to get, and easy to return.

Refer to the Answer Key. What is your score?



How Do You Apply What You Have Learned?

Show that you have learned something by doing this activity.

- I. **Directions:** With available personal protective gears, practice to use the following:



Upper body protection

- Safety goggles - eye goggles, welding mask
- Head gears
- Dust mask



Middle body protection

- Aprons
- Hand gloves



Low body protection

- Safety shoes
- Coveralls



How Well Did You Perform?

Find out by accomplishing the Scoring Rubric honestly and sincerely. Remember it is your learning at stake!

Performance Rubrics

Criteria	5	3	1
Proficiency	Performs the task with competence and exceptional performance	Performs the task with competence and with standard performance	Performs the task with competence but below standard performance
Accuracy	Performs the task with no error	Performs the task with at least 1-2 errors	Performs the task with at least 3-5 errors
Completeness	Performs all the steps in sequence	Performs the task with at least 2-3 steps not met	Performs the task with at least 3-5 steps not met
Safety	Follows all the safety practices as set in the guidelines	Follows the safety practices with at least 1-2 safety measures not met	Follows the safety practices with at least 3-5 safety measures not met

TOTAL _____

RATING SCALE: Points Earned (S) Numerical Rating (PL) Descriptive Rating (PL)

21 – 25 91 - 100 Outstanding

16 – 20 86 - 90 Very Good

11 – 15 81 - 85 Good

06 - 10 76 - 80 Fair

01 - 05 71 - 75 Needs Improvement

WHAT IS YOUR SCORE? _____



How Do You Extend Your Learning?

Directions: Perform one of the following 5S and answer the space with I CAN if you are able to do it. Leave the space blank if you cannot but state your reason why.

1. _____ sorting

Why?

2. _____ setting in order, straightening, Simplifying

Why?

3. _____ sweeping, Shining, Systematic cleaning

Why?

4. _____ standardizing

Why?

5. _____ sustaining

Why?

LEARNING OUTCOME 3

Dispose waste/ used lubricants

PERFORMANCE STANDARDS

- Waste and used materials are disposed in accordance with the standard operational procedures and environmental regulations.
-
- Personal safety in disposing waste and used materials is observed



Materials

- Sample chemical substance /materials
 - Flammable, corrosive, toxic, reactive
- Sample waste/used substance/materials
- Sample chemical /safety labels



What Do You Already Know?

Let us determine how much you already know about the disposing waste/used lubricants. Take this test.

Pretest LO 3

Directions: Write the letter of the correct answer on the space provided. Use your Activity Notebook for your answers.

- Government institutions like the DENR have local policies that protect the citizens from _____ of these hazardous materials and substance.
A. harmful effects
B. good effects
C. neutral effects
D. balance effects
- The effects of hazardous waste materials to human and environment can be
A. managed
B. bought
C. rented
D. loaned
- Industrial _____ is a great concern of environmentalists
A. waste materials
B. waist materials
C. waist substance
D. ways products
- A separate container or trash bin for disposable materials is a _____ habit.
A. bad
B. good
C. not so bad
D. not so good
- Problems on waste materials can be solved if proper attention, information dissemination, training, and _____ is adequately provided in the workplace.
A. compliance
B. hearing
C. observation
D. styling
- The harmful effect of waste materials is so huge that it even affects our
A. earth
B. environment
C. ocean
D. space
- Used _____ oil is a good example of waste material.
A. air compressor
B. lubricating
C. soap
D. tool
- _____ material can immediately change the composition of an object.
A. flammable
B. toxic
C. reactive
D. corrosive
- Toxic material is
A. allergen
B. comforting
C. irritating
D. lethal

10. An inventory of waste materials and substance that can be found in the workshop will be of great help in finding out their
- A. condition
 - B. purpose
 - C. serviceability
 - D. type



What Do You Need To Know?

Read the Information Sheet 3.1 very well then find out how much you can remember and how much you learned by doing Self-check 3.1.

Information Sheet 3.1

↑ WASTE MANAGEMENT

Industrial waste materials are a great concern of environmentalists. Their harmful effect is so huge that it even affects our environment and climate. This is due to improper management of waste materials such as cleaning chemicals used in automotive like solvent, used lubricating and flushing oil, paint remover, and thinners. Problems like these can be solved if proper attention, information dissemination, and training are adequately provided in the workplace.

Government institutions like the Department of Environment and Natural Resources (DENR) have local policies that protect the citizens from harmful effects these hazardous materials and substance may bring. Hazardous materials are those that can be found in the workshop such as **toxic materials** like hydrochloric use in cleaning metal surface and sulfuric acid use in the battery, and Turco or metal conditioner for neutralizing rust. **Flammable materials** like fuel gasoline and thinners are also used in cleaning engine parts. They can give harmful fumes that can generate respiratory and skin irritation. Materials that can easily dissolve metal like anti-rusts are **corrosive materials**. Acid, soldering paste, and Turco can be classified as **reactive materials** that can immediately change the composition of an object.



All of these hazardous, waste materials and substance can paralyze human and definitely lethal if not given serious attention in managing them.

The following are some guidelines to follow when disposing waste and used materials and substance.

1. Have a separate container or trash bin for disposable materials. Different waste materials like used, empty plastics, bottles, cans must not be mixed in one container for easy disposal and segregation.

2. Have a separate container for used and unused materials and substance.

Used oil must not be disposed in the drainage. Doing so will harm the eco-system. This will endanger the lives of water life species and plant life. This must be stored in a container with proper label. Unused oil and other chemical materials must be properly labeled and covered to avoid escape of fumes that may cause instant fire.

In the United States the Environment Protection Agency (EPA) is very strict in implementing protection against careless and improper use and disposal of hazardous waste products. Breaking this law may lead to prosecution.

3. Have an appropriate amount of use of chemical materials or substance. Many unused chemical materials and substance are due to overfill. That is why the excess chemicals cannot be returned back to its container especially if already mixed with other chemicals and cannot be stored for a period of time. This overfill when stored and dried tend to form into another composition and thereby unsafe to use. Disposal of this kind is a problem.

📌 EFFECTS OF AUTOMOTIVE WASTE TO MEN AND ITS ENVIRONMENT

The effects of hazardous waste materials to human and environment is inconceivable. Just imagine the amount spent by the government in services for managing this problem. Aside from this, the audio and print media release they have paid just to promote waste management literacy.

Millions of automobile are on the road every day. Toxic exhaust gas fumes may lead to respiratory disease, and even death. Heat produced may cause skin irritation and respiratory allergy, and other by-products of automotive wastes can cause physical, mental and financial stress.

An inventory of waste materials and substance that can be found in the workshop will be of great help in finding out their condition.

Managing the hazardous waste materials and substance is a great contribution to the nation's economy. Health and safety are preserved. Injury is lessened and harmful effect to environment is reduced if not totally removed.

MATERIALS/SUBSTANCE IN THE WORKSHOP

Materials / Substance	Effects	Condition		Remarks
		(1) Used	(2) Unused	
A. TOXIC Materials	Liver/ kidney cancer, illness, lung irritation, lethal			
• Acid				
• Battery solution				
• Contact cement				
• Paint				
B. FLAMMABLE Materials	Explosive, volatile, combustible, burns, irritation, toxic fumes, foul odor, lethal			
• Brake/Clutch fluids				
• Gasoline				
• Oil				
• Solvent				
• Thinner				
C. CORROSIVE Materials	Skin irritation, foul odor, allergy			
• Anti-rust spray				
• Moist and rusty metals				
• Turco or Metal conditioner				
D. REACTIVE Materials	Burns, toxic fumes, explosive, skin irritation, allergy			
• Acid				
• Soldering paste				
• Turco				



Self-Check 3.1

Directions: Fill-in the blank space by selecting the correct answer. Use your Activity Notebook by writing the letter of your answer.

1. Industrial _____ are a great concern of environmentalists
A. waste materials
B. waist materials
C. waist substance
D. ways products

2. Problems on waste materials can be solved if proper attention, information dissemination, training, and _____ are adequately provided in the workplace.
A. compliance
B. hearing
C. observation
D. styling

3. Government institution like the DENR have local policies that protect the citizens from _____ these hazardous materials and substance.
A. balance effects
B. good effects
C. harmful effects
D. neutral effects

4. A separate container or trash bin for disposable materials is a _____ habit.
A. bad
B. good
C. not so bad
D. not so good

5. The effects of hazardous waste materials to human and environment can be _____.
A. bought
B. loaned
C. managed
D. rented

Refer to the Answer Key. What is your score?



How Do You Apply What You Have Learned?

Show that you learned something by doing this activity.

Operation Sheet 3.1

I. Directions: Perform the following competencies and assess yourself using the Performance rubrics.

PERFORMANCE ASSESSMENT

Name : _____ Year & Section: _____

Course: _____ Time Allotment: _____

Module Title: _____ Grading Period _____

Unit of Competency	Tasks	Date	Time		Score	Performance Level
			Begun	Finished		
LO1 Inspect/Clean Tools and Shop Equipment	Inspect/Clean workshop tools and equipment					
LO2 Store/Arrange Tools and Shop Equipment	Store/Arrange tools and shop equipment					
LO3 Dispose Waste/Used Lubricants	Dispose waste and used lubricants					

Average: _____



How Well Did You Perform?

**Find out by accomplishing the Scoring Rubric honestly and sincerely.
Remember it is your learning at stake!**

Performance Rubrics

Criteria	5	3	1
Proficiency	Performs the task with competence and exceptional performance	Performs the task with competence and with standard performance	Performs the task with competence but below standard performance
Accuracy	Performs the task with no error	Performs the task with at least 1-2 errors	Performs the task with at least 3-5 errors
Completeness	Performs all the steps in sequence	Performs the task with at least 2-3 steps not met	Performs the task with at least 3-5 steps not met
Safety	Follows all the safety practices as set in the guidelines	Follows the safety practices with at least 1-2 safety measures not met	Follows the safety practices with at least 3-5 safety measures not met

TOTAL _____

RATING SCALE : Points Earned (S) Rating (PL)	Numerical Rating (PL)	Descriptive
21 – 25	91 - 100	Outstanding
16 – 20	86 - 90	Very Good
11 – 15	81 - 85	Good
06 - 10	Fair	
01 - 05 Improvement	71 - 75	Needs

WHAT IS YOUR SCORE? _____



How Do You Extend Your Learning?

Directions: Below is a puzzle interconnected with one another. List down names of automotive waste materials/substance and their effects to human and environment. Use your Activity Notebook in answering the activity.

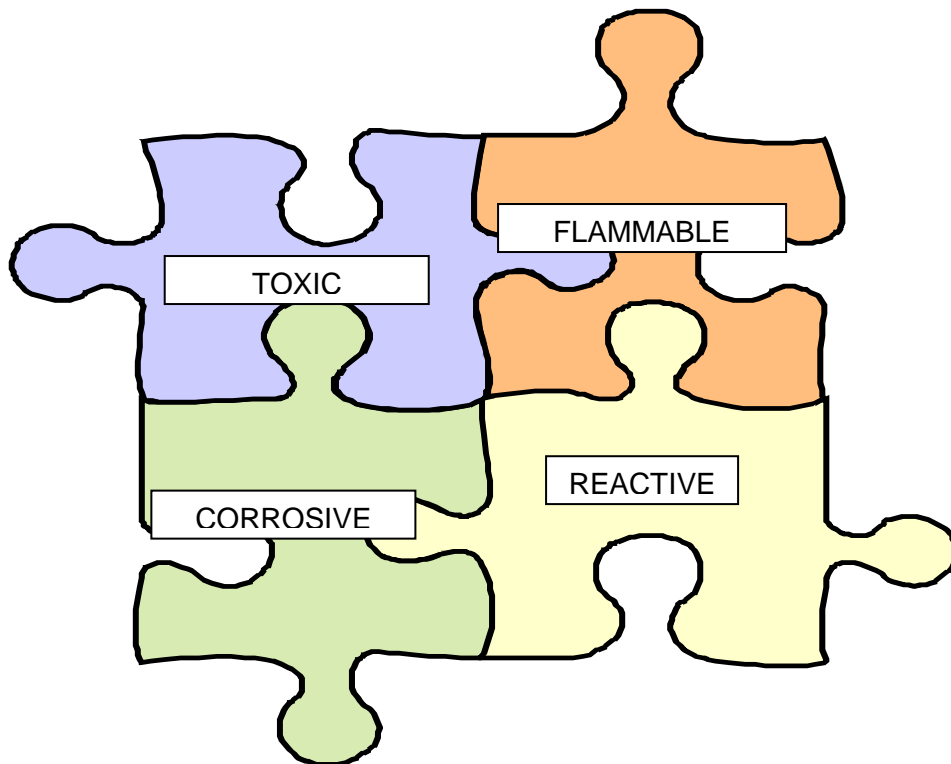

Congratulations! You did a great job! Rest and relax a while then move on to the next lesson. Good luck!

REFERENCES

LO1

- Swing Crispin, Frederic, Dictionary of Technical TermsThe Bruce Publishing Co.: 1948.
- Chilton's Easy Car Care. Chilton Book Company. 3rd Ed. Chilton Way, Radnor, PA 19089
- Stockel, Martin W. Auto mechanics Fundamentals. The Goodheart - Willcox Company, Inc. 1978
- The Oxford Dictionary of Current English. New Revised Ed. Oxford University Press, 1998.
- Popular Mechanics Guide To Auto Basic Repair and Maintenance. Book Division The Hearst Corporation, New York, NY
- www.google.com.ph
- en.wikipedia.org

LO 2

- Swing Crispin, Frederic, Dictionary of Technical TermsThe Bruce Publishing Co.: 1948.
- Chilton's Easy Car Care. Chilton Book Company. 3rd Ed. Chilton Way, Radnor, PA 19089
- Stockel, Martin W. Auto mechanics Fundamentals. The Goodheart - Willcox Company, Inc. 1978
- The Oxford Dictionary of Current English. New Revised Ed. Oxford University Press, 1998.
- Popular Mechanics Guide To Auto Basic Repair and Maintenance. Book Division The Hearst Corporation, New York, NY

LO 3

- Swing Crispin, Frederic, Dictionary of Technical TermsThe Bruce Publishing Co.:1948.
- Chilton's Easy Car Care. Chilton Book Company. 3rd Ed. Chilton Way, Radnor, PA 19089
- Stockel, Martin W. Auto mechanics Fundamentals. The Goodheart - Willcox Company, Inc. 1978
- The Oxford Dictionary of Current English. New Revised Ed. Oxford University Press, 1998.
- Popular Mechanics Guide To Auto Basic Repair and Maintenance. Book Division The Hearst Corporation, New York, NY
- www.google.com.ph
- en.wikipedia.org

LESSON 5

Practice Occupational Health and Safety Procedures



LEARNING OUTCOMES:

At the end of this Lesson, you are expected to do the following:

- LO 1. identify hazards and risks;
- LO 2. evaluate hazards and risks;
- LO 3. control hazards and risks; and
- LO 4. maintain occupational safety and awareness



Definition of Terms

Avalanche - also called a snow slide or snow slip. It is a sudden, drastic flow of snow down a slope, occurring when either natural triggers, such as loading from new snow or rain, or artificial triggers, such as snowmobilers, explosives or backcountry skiers, overload the snowpack

Capacitor- formerly known as condenser. It is a [passive two-terminal electrical component](#) used to store [energy](#) in an [electric field](#). Capacitors are widely used as parts of [electrical circuits](#) in many common electrical devices

Cliff - is a significant vertical, or near vertical, rock exposure

Colleagues - a person with whom one is associated in a profession or occupation

Combustibility- a measure of how easily a substance will set on fire, through [fire](#) or [combustion](#).

Dermatitis- derives from Greek derma "skin" + -itis "inflammation". Dermatitis symptoms vary with all different forms of the condition. They range from skin rashes to bumpy rashes or including blisters. Although every type of dermatitis has different symptoms, there are certain signs that are common for all of them, including redness of the skin, [swelling](#), [itching](#) and skin lesions and sometimes oozing and scarring

Earmuffs - objects designed to cover a person's [ears](#) for [protection](#). They consist of a [thermoplastic](#) or metal head-band, that fits over the top of the [head](#), and a pad at each end, to cover the external ears

Electrode- an [electrical conductor](#) used to make contact with a nonmetallic part of a [circuit](#) (e.g. a [semiconductor](#), an [electrolyte](#) or a [vacuum](#)). The word was coined by the scientist [Michael Faraday](#) from the [Greek](#) words elektron (meaning [amber](#), from which the word [electricity](#) is derived) and hodos, a way^[1]

Fatigue - the decreased capacity or complete inability of an organism, an organ, or a part to function normally because of excessive stimulation or prolonged exertion

Fumes - vapor, gas, or smoke, especially if irritating, harmful, or strong

Glare - to express by staring angrily

Glazing - also (less commonly) used to describe the insertion of ophthalmic lenses into an eyeglass frame

Hazardous fumes- to [expose](#) to the [action](#) of fumes; to [treat](#) with [vapors](#), [smoke](#), etc.; as, to [bleachstraw](#) by [fuming](#) it with sulfur; to fill with [fumes](#), [vapors](#), odors, etc, as a [room](#). She fumed the [temple](#) with an [odorous flame](#)

Hazards- a term used to describe something that has the potential to cause harm

Hierarchy - a series in which each element is graded or ranked

Hydrazine -also called diazane. It is an [inorganic compound](#) with the [formula](#) N₂H₄. It is a colorless flammable liquid with an [ammonia](#)-like odor. Hydrazine is used within both nuclear and conventional electrical [power plant](#) steam cycles to control concentrations of dissolved oxygen in an effort to reduce corrosion

Illness - sometimes referred to as ill-health or ailment. It is a state of poor [health](#). Illness is sometimes considered another word for [disease](#)

Isolating - to set apart (a component, circuit, or system) from a source of electricity or to set apart or cut off from others

Jeopardy - in a situation in which someone or something is exposed to possible injury, loss, or in danger

Jerky movement - a condition which is associated with unintentional erratic or irregular movements

Legislation - the act or process of making laws; enactment

Pedestrians - a person traveling on foot, whether [walking](#) or [running](#). In some communities, those traveling using [roller skates](#) or [skateboards](#) are also considered to be pedestrians

Risks - a measure of the possibility of a specific harmful effect in given circumstances

Severity - used of the degree of something undesirable e.g. pain or weather

Tendinitis - is informally also tendonitis, It is the [inflammation](#) of a [tendon](#) (the suffix -itis denotes diseases characterized by inflammation), is a type of [tendinopathy](#) often confused with the more common [tendinosis](#), which has similar symptoms but requires different treatment.^[1] The term tendinitis should be reserved for tendon injuries that involve larger-scale acute injuries accompanied by inflammation

Triggered - a device that activates or releases or causes something to happen

Ventilation - the process of "changing" or replacing air in any space to provide high [indoor air quality](#) (i.e. to control temperature, replenish oxygen, or remove moisture, odors, smoke, heat, dust, airborne bacteria, and carbon dioxide). Ventilation is used to remove unpleasant smells and excessive moisture, introduce outside air, to keep interior building air circulating, and to prevent stagnation of the interior air

Workplace - applies to a wide range of premises including shops, offices, schools, hospitals and places of entertainment. It also includes the common parts of shared buildings and temporary work sites (but not construction sites)

[Empty rounded rectangular box]

[Empty rounded rectangular box]

PERFORMANCE STANDARDS

[Empty rounded rectangular box]



[Empty rounded rectangular box]

- Hazard signs and symbols in home, school, workplace
- Radio
- Thinner and acid



What Do You Already Know?

Let us determine how much you already know about identifying hazards and risks. Take this test.

Pretest LO 1

Directions: Write the letter of the correct answer on the blank space provided. Use your Activity Notebook for your answers.

1. A **hazard** is any source of potential damage, harm or adverse effects on properties or someone's health under certain conditions at
A. leisure B. play C. rest D. work
2. Hazards are classified into ___ different types.
A. Two B. four C. six D. eight
3. Manual handling includes any activity that requires a person to lift, push, pull, carry, hold or move an object, person or
A. animal B. race C. thing D. tool
4. **Welding** operations generate hazardous
A. air B. fumes C. steam D. vapor
5. A hazardous substance is any substance, which can potentially harm the health and safety of workers. Hazardous substance must be
A. advertise B. insured C. labeled D. promoted

Criteria for Evaluating Results of Pre-Test

100%-skip the Learning Outcome and proceed to the next Learning Outcome

99%-below – Go through the Learning Outcome



What Do You Need To Know?

Read the Information Sheet 1.1 very well then find out how much you can remember and how much you learned by doing Self-check 1.1.

Information Sheet 1.1

In any place, or corner, hazard could be present. At home, on the street, in school or in the workplace, anything could happen and may cause some damage to an individual or to property. Example: anything could happen with an extension cord lying on a floor, from a simple tip-off to electric shock or even more.

WHAT IS HAZARD?

A **hazard** is any source of potential damage, harm or adverse effects on properties or someone's health under certain conditions at work. Workplace hazards can come from a wide range of sources. General examples include any substance, material, process, practice, etc that have the ability to cause harm or adverse health effect to a person under certain conditions. See table below

Examples of Hazards and Their Effects		
Workplace Hazard	Example of Hazard	Example of Harm Caused
Object/tool	Knife	Cut
Substance	Benzene	Leukemia
Material	Asbestos	Mesothelioma
Source of Energy	Electricity	Shock, electrocution
Condition	Wet floor	Slips, falls
Process	Welding	Metal fume fever
Practice	Hard rock mining	Silicosis

As shown in the table above, workplace hazards also include practices or conditions that release **uncontrolled** energy like:

- an object that could fall from a height (potential or gravitational energy),
- a run-away chemical reaction (chemical energy),
- the release of compressed gas or steam (pressure; high temperature),
- entanglement of hair or clothing in a rotating equipment (kinetic energy), or
- contact with electrodes of a battery or capacitor (electrical energy).

3 Modes / Forms of a hazard

- **Dormant** – The situation has the potential to be hazardous, but no people, property, or environment is currently affected by this. For instance, a hillside may be unstable, with the potential for a landslide, but there is nothing below or on the hillside that could be affected. For a shop work area, dormant hazard is an undetected hazard created by the design of equipment or layout of the workshop area.
- **Armed** – The situation has the potential to be hazardous and there are people, property, or environment that is in potential harm's way. This is a dormant hazard that has become armed and ready to cause harm during certain work circumstances.
- **Active** - A harmful incident involving the hazard has actually occurred. Often this is referred to not as an "active hazard" but as an accident, emergency, incident, or disaster. This is an armed hazard triggered into action by the right combination of factors. *At this point it is too late to take any preventive action to escape injury or avoid death.*

Classes of hazard

	<i>Example of forms / modes of hazard</i>		
	<i>Dormant</i>	<i>Armed</i>	<i>Active</i>
<i>Snowy cliff</i>	<i>Anytime Avalanche could take place while no one on its base</i>	<i>Skiers are on the base of the snowy cliff</i>	<i>An avalanche occur while some skiers are on the base of the cliff</i>
<i>Auto repair shop</i>	<i>An engine is hooked-up by a chain block (hoist)</i>	<i>The engine is raised-off from the car's engine compartment</i>	<i>The chain snaps and the engine knocks down on the car.</i>

Hazards are classified into six different types. They are

- **Physical** - includes floors, stairs, work platforms, steps, ladders, fire, falling objects, slippery surfaces, manual handling (lifting, pushing, pulling), excessively loud and prolonged noise, vibration, heat and cold, radiation, poor lighting, ventilation, air quality
- **Mechanical and/or electrical** - includes electricity, machinery, equipment, pressure vessels, dangerous goods, forklifts, cranes, hoists
- **Chemical** - includes chemical substances such as acids or poisons and those that could lead to fire or explosion, cleaning agents, dusts and fumes from various processes such as welding
- **Biological** - includes bacteria, viruses, mould, mildew, insects, vermin, animals
- **Psychosocial environment** - includes workplace stressors arising from a variety of sources.
- **Ergonomic**- repetitive movements, improper set up of workstation, etc.,

WHAT IS RISK?

Risk is the chance or probability that a person will be harmed or experience an adverse health effect if exposed to a hazard. In an auto repair shop, doing most of the jobs place a technician in risky situation. Example, the mechanic is exposed to danger while performing underchassis repairs, he is at risk. There are dangers that may actually become an accident like a bolt snaps while loosening and the mechanics hand strikes hard on other component. It may also apply to situations with property or equipment loss, like the engine in above example would experience damage from a knock down, and the car itself would be damaged too.



Hazard VS Risk

Mostly these two words are used interchangeably with one another. From above statements in this lesson, hazard and risk have its own identity which are closely related to one another. Hazard is the possible danger that could occur when some factors would trigger such event while risk is the possible harm which may result if given danger becomes active. Simply hazard is a possible cause while risk is a possible negative effect.



“hazard is a possible cause while risk is a possible negative effect”

IDENTIFYING HAZARDS AT WORK



The process of identifying and fixing potential hazards in the workplace is called hazard management - a simple procedure where you assess and control the risk of hazards to workers. A workplace hazard is something that has the potential to harm the health and safety of people at work.

Some identified workplace hazards:

- **Manual Handling**

Manual handling includes any activity that requires a person to lift, push, pull, carry, hold or move an object, person or thing. The weight of the object, frequency of manual handling, avoiding sudden or jerky movements, planning the move or lift, lighting and surfaces all need to be considered.



Lifting and moving equipment and materials, panel beating, and working in awkward postures (such as removing or replacing engine parts under car bonnets) are some examples of manual handling tasks you may have to do in the automotive industry.

At times, your tasks may involve bending and stretching as well as twisting sideways, or working with materials and equipment above shoulder height. All of these increase the risk of manual handling injury. Many engine parts are too heavy to lift safely, and storage of items such as vehicle tires on racking, while it may be easy at ground level where they can be rolled in, presents a manual handling risk if you attempt to lift them.



- **Machinery and Equipment**

Poor design, poor maintenance, inexperience and lack of training increase the risk of injury from tools and equipment and its operators.

Hoists are used to elevate vehicles so repairs can be made safely by people working beneath the vehicle. The safe operation of hoists is essential, and depends upon competent operators and strict maintenance and inspection routines. Every hoist must be subjected to a pre-operation check, and routine inspection and maintenance must be carried out at least every three months.



Air compressors are dangerous and should never be used to blow dust or dirt from clothing or work materials. Compressed air accidentally blown into an open wound can be fatal because air can be forced into bloodstream. **Asbestos** has been used in some vehicle components such as brake lining, there is the possibility that asbestos fibre may be found in automotive workshops: compressed air should never be used to blow what may appear to be dust from these items.



Engines have exposed moving parts (fans and belts) which could catch fingers, and exhaust emissions can be fatal if they build up in an enclosed area.

If a vehicle moves while a worker is beneath it, a fatality or serious injury could result.



- **Powered Tools and Hand Tools**

Many of the tools used in the automotive industry are powered by electricity. Your employer must make sure all electrical machinery and equipment are kept in good working order. Electrical plugs and switches must be checked regularly to make sure they are not damaged. Leads can become split or frayed, and these too must be inspected for wear each time they are used. Electrically powered tools must be tested and tagged regularly.

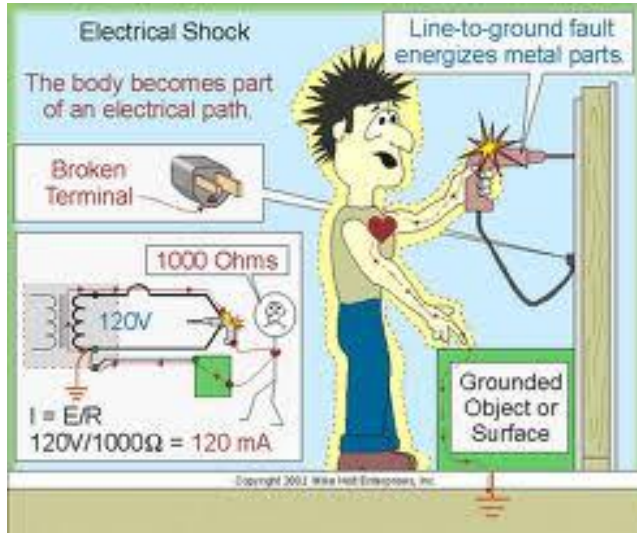

Hand tools – such as spanners, wrenches and screwdrivers – will be used in every job. The most common injuries from use of hand tools are to the hands and fingers. Using the correct tools is an important way to avoid these injuries.



Welding operations generate hazardous fumes and should be separated from other workshop activities and from workers who may not be protected by fume extraction systems, ventilation or appropriate PPE. It may be possible to weld out of doors in good weather; at times, risk controls will be needed to prevent exposing the welder and other workers to risk.

- **Slips, Trips and Falls**

A slip or fall can cause injury to the arms, legs, back, neck or head. Neck and head injuries can cause damage to the spinal cord and nervous system. Many employees have suffered permanent disabling injuries as a result of a fall.

Poor 'housekeeping' in the automotive industry leads to slips, trips and falls. Engine parts, air lines and hoses left on the workshop floor can all result in preventable accidents. Metal bins should be provided for waste disposal. These should not be allowed to overflow.

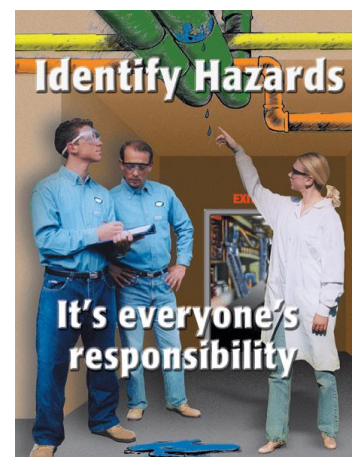

- **Confined Spaces**

Some automotive workshops have pits to enable work to be done if a hoist is not available. The vehicle is driven over the pit, and the mechanic works from beneath. This work should never be done by someone working alone: a second person should be on hand (outside the pit) to monitor the work and to provide assistance. Because carbon monoxide (from the vehicle exhaust) is heavier than air, the fumes may build up in the 'confined space' under the vehicle. These fumes need not be only from the vehicle being worked on: if other engines are running nearby, there is still a significant risk of exhaust emissions collecting in the pit. Good ventilation is essential in automotive workshops. Engine bay doors should be fully open at all times. If weather conditions prevent this, the work must be evaluated and tasks such as spray painting, which could result in a build-up of fumes, should be postponed.

Respirators will be necessary for a number of jobs in an automotive workshop. Dust masks do not provide protection against vehicle fumes and gases, or paint drift from spraying operations. Employers must find out what kind of breathing protection is needed and make sure all workers are issued with it and instructed in its correct use.

- **Noise**

Excessive noise can cause permanent hearing loss and is probably the most common cause of hearing loss in adult males. Hearing loss limits a person's ability to communicate at work, home and socially. There is no medical treatment and hearing aids offer limited benefit.

Employees in the automotive industry work with noisy tools and machinery such as wheel removers, compressors, grinders and drills. While in an automotive workshop, you may be exposed to noise levels exceeding 85 decibels or dB(A) that could lead to hearing loss.



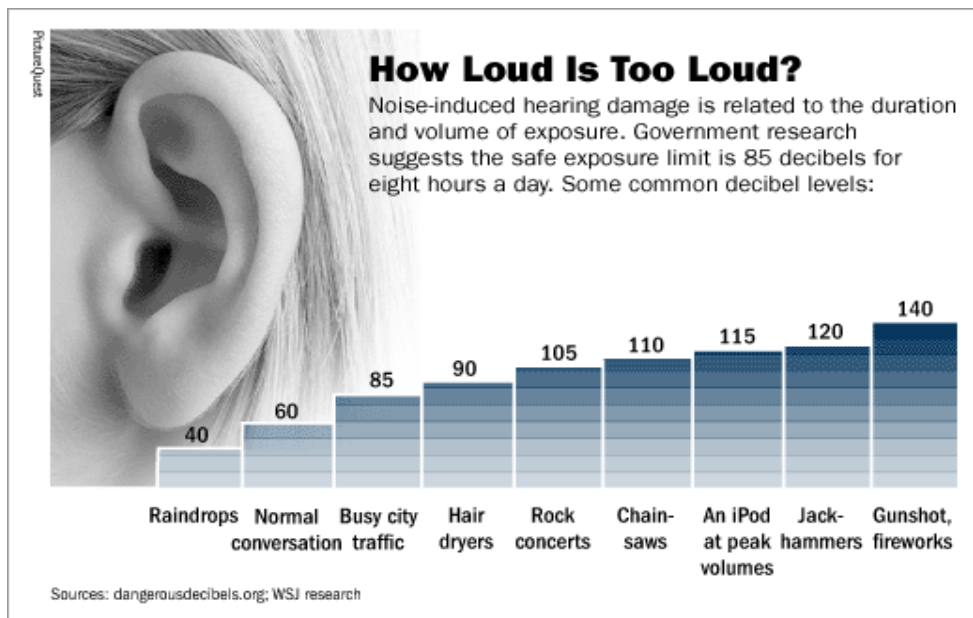

- **Hazardous Substances**

A hazardous substance is any substance, which can potentially harm the health and safety of workers. Labels and material safety data sheets (MSDS) provide OHS information about the substance.

1. **Hazardous substances and dangerous goods.** *The automotive industry requires the use of dangerous goods (such as petrol and gas) and hazardous substances (such as acids, oils, diesel and solvents).*
2. **Petrol containers and gas cylinders** must be stored securely, away from heat sources and out of the path of vehicle traffic. These are highly flammable substances and could cause fatality and serious injury if not carefully handled and stored.
3. **Solvents** are often used as cleaners or degreasers. They can enter the body when a person breathes in their vapor, through skin contact, or through the mouth from contact with food or fingers.

Solvents can impair memory and cause headaches, dizziness, fatigue, mood changes or nausea. Exposure to high levels of solvents can cause liver damage, unconsciousness, death and cancers.

4. **Spray paints** contain harmful substances. Inhaling paint fumes may cause occupational asthma. Long term exposure can affect the brain, damage the reproductive system and cause kidney or liver damage. Contact with the skin may cause dermatitis (an inflammation of the skin).
5. **Batteries** contain acid and must be treated with caution. If you are asked to handle batteries, you must be given instruction and provided with appropriate PPE - rubber gloves, eye protection (you may need goggles to avoid splashes), overalls and solid work boots. (You should always wear work boots - not sneakers or soft shoes - in the automotive industry, no matter what job you are doing.)

DIFFERENT HAZARDOUS MATERIAL / SUBSTANCE AND ITS EFFECT



CORROSIVE MATERIAL

Corrosive materials can attack (*corrode*) metals or cause permanent damage to human tissues such as the skin and eyes on contact. Burning, scarring, and blindness may result from skin or eye contact. Corrosive materials may also cause metal containers or structural materials to become weak and eventually to leak or collapse. Ammonia, fluorine, and hydrochloric acid are examples of corrosive substances.



FLAMMABLE AND COMBUSTIBLE MATERIAL

Flammable or combustible materials will ignite and continue to burn if exposed to a flame or source of ignition. Materials are classified as a flammable gas, flammable aerosol, flammable liquid, combustible liquid, flammable solid, or reactive flammable material. Methane, acetone, aniline, and lithium hydride are examples of flammable materials.



OXIDIZING MATERIAL

An oxidizing material may or may not burn itself, but will release oxygen or another oxidizing substance, and thereby causes or contributes to the combustion of another material. Ozone, chlorine, and nitrogen dioxide are oxidizing materials. These chemicals will support a fire and are highly reactive.



DANGEROUSLY REACTIVE MATERIAL

Dangerously reactive materials may undergo vigorous polymerization, decomposition or condensation. They may react violently under conditions of shock or an increase in pressure or temperature. They may also react vigorously with water to release a toxic gas. Ozone, hydrazine, and benzoyl peroxide are examples of dangerously reactive materials.



COMPRESSED GAS

A compressed gas is a material which is a gas at normal room temperature (20 C) and pressure but is packaged as a pressured gas, dissolved gas or gas liquified by compression or refrigeration.

The hazard from these materials, aside from their chemical nature, arises from sudden loss of integrity of the container. A compressed gas cylinder is usually quite heavy and when ruptured can become a projectile with the potential to cause significant damage. Acetylene and oxygen are examples of compressed gases.



POISONOUS AND INFECTIOUS MATERIALS

1- Materials Causing Immediate and Serious Toxic Effects

These materials may be classified as toxic or very toxic based on information such as LD50 or LC50.

Examples: Styrene, hydrogen cyanide are very toxic substances.



2 - Materials Causing Other Toxic Effects

A pure substance or mixture that may be any one of the following: a carcinogen, teratogen, reproductive toxin, respiratory tract sensitizer, irritant or chronic toxic hazard.

Examples: Asbestos causes cancer, ammonia is an irritant.

3 - Biohazardous Infectious Material



This classification includes any organisms and the toxins produced by these

organisms that have been shown to cause disease or are believed to cause

disease in either humans or animals.

For example, a blood sample containing the Hepatitis B virus is a biohazardous infectious material. It may cause hepatitis in persons exposed to it.



How Much Have You Learned?

Self-Check 1.1

Directions: Select the best answer. Use your Activity notebook in writing your answer.

- It is a term used in workplaces that defines a possible source of harm to person, damage to property or environment.
A. risk B. hazard C. accident D. danger
- The probability of getting harmed or damaged occurring from exposure to a hazard.
A. risk B. hazard C. accident D. danger
- What form of hazard is the situation that has a potential to be hazardous, but no people, property, or environment is currently affected by this?
A. armed B. active C. dormant D. hidden
- What materials/substances can attack metals or cause permanent damage to human tissues?
A. oxidizing materials B. compressed Gas C. corrosive materials D. solvent
- This material has been used as the component of the brake lining of some vehicles, which when in dust form become hazardous to health when inhaled.
A. Hydrazine B. asbestos C. spray paint D. solvent
- This can cause permanent hearing loss and is probably the most common cause of hearing loss in adult males working in a very busy industrial plant like automotive industry.
A. Hazardous substance B. Slips, Trips and fall C. Noise D. solvent
- What infectious materials/substances are produced by organism and toxins?
A. biohazardous infectious materials C. oxidizing materials
B. materials causing other toxic effects D. corrosive materials
- What materials which ignite and continue to burn if exposed to a flame or source of ignition?
A. corrosive materials B. flammable and combustible material
C. oxidizing materials D. compressed gas
- Used as a cleaner or degreaser, which is considered hazardous if it enters the body when a person breathes in their vapour, through skin contact, or through the mouth from contact with food or fingers.
A. spray paints B. solvents C. batteries D. petrol
container
- This equipment is hazardous when not properly used like if accidentally points to an open wound could force air to blood stream and can be fatal.
A. fan blades B. solvent C. hand tools D. compressor

Refer to the Answer Key. What is your score?



How Do You Apply What You Have Learned?

Show that you learned something by doing this activity.

Activity Sheet 1.1

Crossword

Task: Follow the clues below to fill in the blanks:

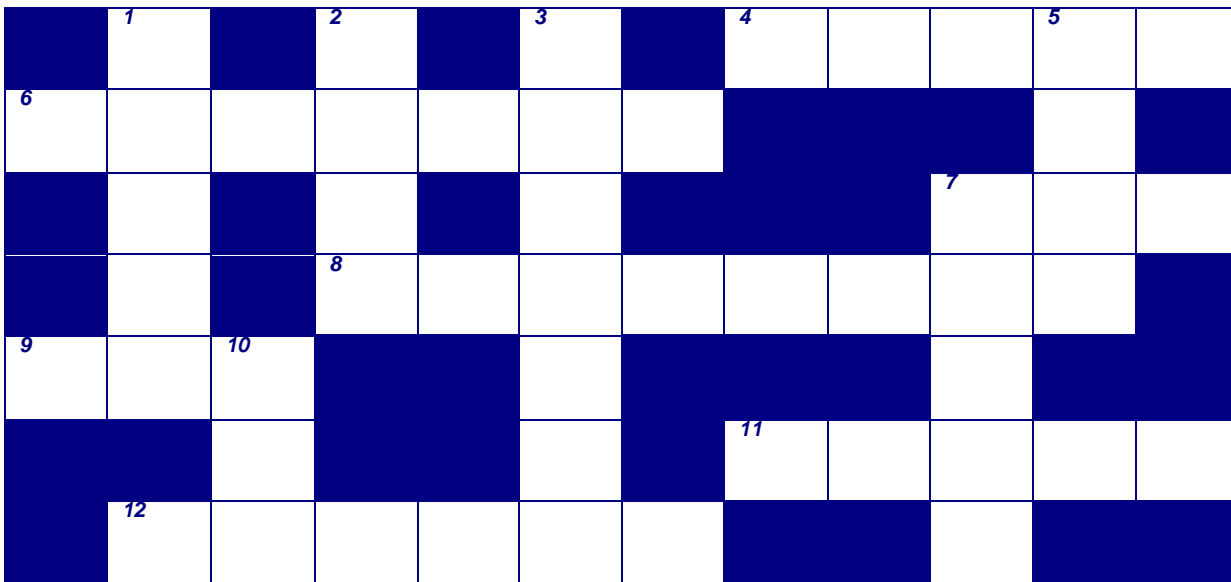

Across

- 4. Power _____ used in workplaces can be noisy
- 6. Unit of measuring noise levels
- 7. If you are unsure, ____ your supervisor
- 8. One kind of personal protective equipment (PPE) for hearing
- 9. Of advanced age
- 11 Loud sound
- 12. Operating machinery without hearing protection can _____ hearing

Down

- 1. A noise _____ of 85 dB(A) and above can cause hearing loss.
- 2. Noise is a constant hazard at a construction _____
- 3. The sense by which sound is perceived
- 5. Hearing _____ can be prevented
- 7. Once more
- 10. Abbreviation for “decibel”

WHAT IS YOUR SCORE? _____



How Well Did You Perform?

**Find out by accomplishing the Scoring Rubric honestly and sincerely.
Remember it is your learning at stake!**

Score Rating:

10 points – Proceed to the next lesson.

8 points – Proceed to the next lesson but accomplish incomplete competency.

6 points – Accomplish the incomplete competency before taking the next lesson.

4 points – Retake the task.

2 points – Retake the task.

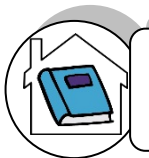

How Do You Extend Your Learning?

Directions: Visit your nearest industrial shop. Introduce yourself as automotive servicing student. Interview a worker on the following:

1. The effects of hazardous substance in health and environment.
2. The importance of safety in the workplace.
3. Discuss your findings in the class.

LEARNING OUTCOME 2

Evaluate hazards and risks

PERFORMANCE STANDARDS

- Effects of hazards are determined.
- OHS /ECC issues and concerns are identified in accordance with workplace requirements and legislation.
- OHS procedures for controlling hazards and risk are strictly followed.
- OHS personal records are filled up in accordance with workplace requirements.
- 5.Design of facilities/fixture to human facility is recognized



Materials

- Picture of effects of hazards
- Picture of different hand movements



What Do You Already Know?

Let us determine how much you already know about evaluating hazards and risks
Take this test.

Pretest LO 2

Directions: Write the letter of the correct answer on the space provided. Use your Activity Notebook for your answers.

1. What is the health problem when a person's ability to control the demands of work is threatened?
A. heart disease B. stress C. musculoskeletal disorder D. allergies
2. What is the health problem when a worker tries to overcome an existing workload in excess of his ability?
A. heart disease B. stress C. musculoskeletal disorder D. allergies
3. It is a group of painful disorder of muscles, tendons, and nerves.
A. heart disease B. stress C. musculoskeletal disorder D. allergies
4. Locate the area of pain in the repetitive, horizontal movement of the wrist to the extreme range.
A. elbow B. wrist and palm C. neck and shoulder D. feet
5. Locate the areas of pain while extending the forearm in a repetitive bending from the elbow.
A. elbow B. wrist and palm C. neck and shoulder D. feet
6. Locate the pain in reaching movements where in the shoulder is reaching above level.
A. elbow B. wrist and palm C. neck and shoulder D. feet

7. Locate the area of pain in reaching movements where in the trunk is reaching behind.
- A. elbow B. wrist and palm C. neck and shoulder D. feet
8. What health problem is the most common cause of occupational disease and accounts for most workdays lost?
- A. heart disease B. stress C. musculoskeletal disorder D. allergies
9. What provide the workers with minimum standards of health and safety in the workplace?
- A. legislation B. stress C. musculoskeletal disorder D. allergies
10. What are the four terms used in health and safety legislation?
- A. act, regulation, code of practice and allergies
- B. act, regulation, allergies and stress
- C. act, regulation, code of practice and guide
- D. act, regulation, code of practice and musculoskeletal disorder

Criteria for Evaluating Results of Pre-Test

100% - skip the Learning Outcome and proceed to the next Learning Outcome

99 % - below – Go through the Learning Outcome



What Do You Need To Know?

Read the Information Sheet 2.1 very well then find out how much you can remember and how much you learned by doing Self-check 2.1.

Information Sheet 2.1

A. EFFECT OF HAZARD ON HEALTH

Exposure to hazards in the workplace can lead to serious illness.

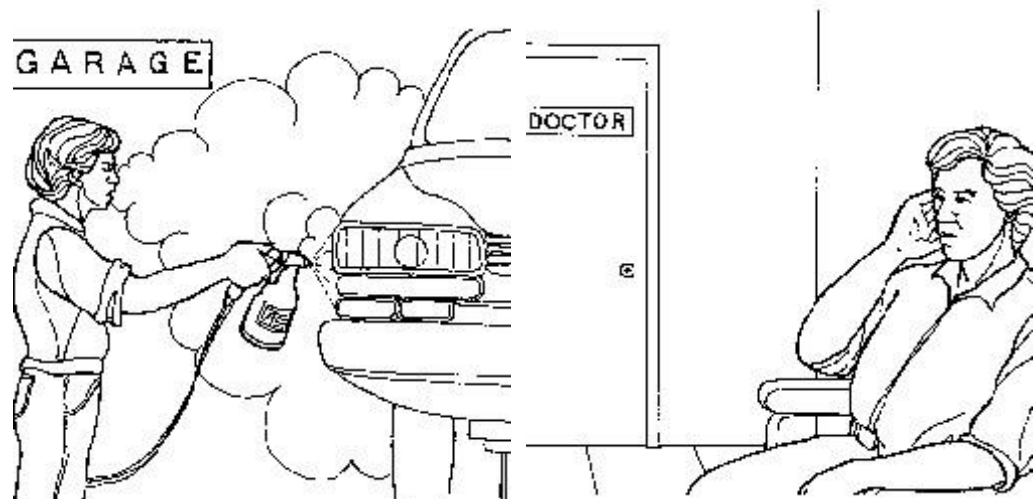

In any workplace, hazard is built-in with it. We cannot deny the existence of danger since a workplace is a site where there are many risky conditions, materials or substances, tools and equipment, and practices which may bring jeopardy to humans, health, property or environment. In the previous topics you have identified the different sources of hazard present in a workplace.

Hazards are threat to human life or health whenever a person is performing his or her job in the workplace. Simply, a mechanic is exposed to threat most of the time from simple tools to equipment, from fumes to solvent.

Some occupational diseases have been recognized for many years, and affect workers in different ways depending on the nature of the hazard, the route of exposure, the dose, etc. Some well known occupational diseases include:

- **Asbestosis** (caused by asbestos, which is common in insulation, automobile brake linings, etc.);
- **Silicosis** (caused by silica, which is common in mining, sandblasting, etc.);
- **Lead poisoning** (caused by lead, which is common in battery plants, paint factories, etc.);

- **Noise-induced hearing loss** (caused by noise, which is common in many workplaces, including airports, and workplaces where noisy machines, such as presses or drills, etc. are used).



ASBESTOSIS DISEASE



SILICOSIS DISEASE



LEAD POISONING

There are also a number of potentially crippling health problems that can be associated with poor working conditions, including:

- Stress-related disorders.
- heart disease;
- musculoskeletal disorders such as permanent back injuries or muscle disorders;
- allergies;
- reproductive problems;

Stress occurs in many different circumstances, but is particularly strong when a person's ability to control the demands of work is threatened. The stressful experience is intensified if no help is available from colleagues or supervisors at work.

Heart disease related to work, sometimes a result of stressful condition that a worker tries to overcome an existing workload in excess of his ability. Stress is becoming more hazardous when it is associated to difficulties with work relationship with bosses or with co-worker. This may result to less concentration to work which may lead into poor practice, eventually creating more hazards. And according to studies that high level anger and stress contributes to the development of heart diseases.



The more hours people worked in a day, the higher their risk of developing coronary heart disease, the results of the study suggested. People who worked 10 hours a day had a 45 percent higher risk of heart disease and those who worked 11 hours a day had a 67 percent higher risk of heart disease than people who worked 7 to 8 hours a day, according to the study. (Long Work Hours Raise Heart Disease Risk Dramatically - MyHealthNewsDaily Staff . Apr 2011)

Work-related musculoskeletal disorders (WMSDs) are a group of painful disorders of muscles, tendons, and nerves. Carpal tunnel syndrome, tendonitis, thoracic outlet syndrome, and tension neck syndrome are examples. Work activities which are frequent and repetitive, or activities with awkward postures cause these disorders which may be painful during work or at rest.

Almost all work requires the use of the arms and hands. Therefore, most WMSD affect the hands, wrists, elbows, neck, and shoulders. Work using the legs can lead to WMSD of the legs, hips, ankles, and feet. Some back problems also result from repetitive activities.

WMSDs are recognized as leading causes of significant human suffering, loss of productivity, and economic burdens on society.

WMSDs arise from ordinary arm and hand movements such as bending, straightening, gripping, holding, twisting, clenching and reaching. These common movements are not particularly harmful in the ordinary activities of daily life. What makes them hazardous in work situations is the continual repetition, often in a forceful manner, and most of all, the speed of the movements and the lack of time for recovery between them. WMSDs are associated with work patterns that include:

- Fixed or constrained body positions
- Continual repetition of movements
- Force concentrated on small parts of the body, such as the hand or wrist
- A pace of work that does not allow sufficient recovery between movements

Generally, none of these factors acts separately to cause WMSD. WMSDs commonly occur as a result of a combination and interaction among them.

Heat, cold and vibration also contribute to the development of WMSD. Poor layout of the workstation and improper selection of equipment and tools can lead to these hazardous body movements.

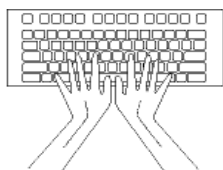

Hazardous movements of the hand

Areas of Pain: wrist and palm



Body Movement:

- repetitive, horizontal or vertical movements of the wrist to the extreme ranges
- moving fingers while the wrist is in an extreme position

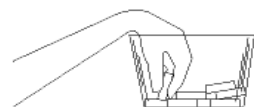

Exerting force while extending forearm



Areas of Pain: elbow

Body Movement:

- repetitive bending or straightening of the elbow from its neutral position (at a right angle)
- twisting the wrist and forearm

Hazardous reaching movements - reaching forward

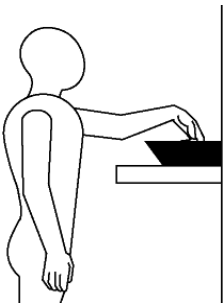

Areas of Pain: neck and shoulder

Body Movement:

- reaching above shoulder level

Hazardous reaching movements - reaching above shoulder level

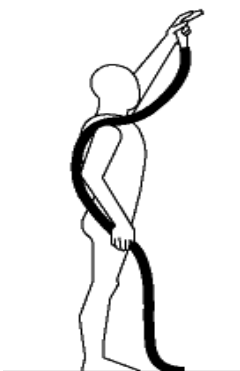

Areas of Pain: neck and shoulder

Body Movement:

- reaching far out in front of the body

Hazardous reaching movements - reaching behind the trunk

Areas of Pain: neck and shoulder

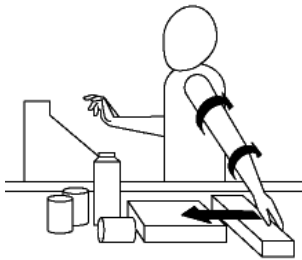

Body Movement:

- reaching behind the trunk
- twisting the arm

Allergies. Occupational Dermatitis is by far the most common cause of occupational disease and accounts for most workdays lost. Contact dermatitis makes up the majority of work related diseases, mostly in the form of non-allergic irritant dermatitis. Allergic contact dermatitis is becoming more prevalent and accounts for 20% of work related skin disease.

SOME HAZARDOUS SUBSTANCES THAT CAUSE LOCAL AND SYSTEMIC EFFECTS

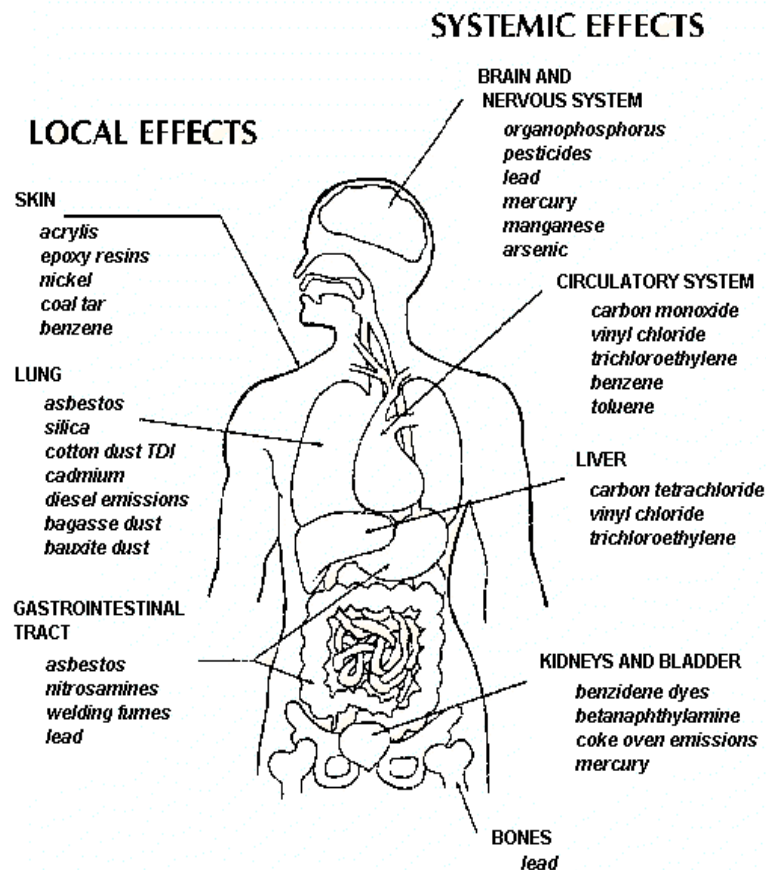

B. EFFECT OF HAZARD ON WORKER AND EMPLOYER

How much does an occupational disease or accident cost?

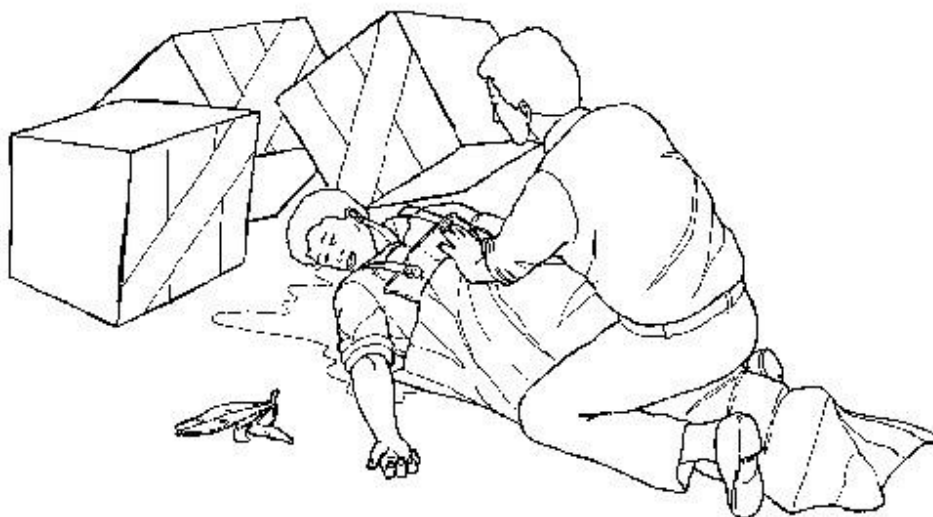

	<i>Direct cost</i>	<i>Indirect cost</i>
<i>Worker</i>	<ul style="list-style-type: none"> • the pain and suffering of the injury or illness; • the loss of income; • the possible loss of a job; • Health-care costs. 	<ul style="list-style-type: none"> • can be four to ten times greater than the direct costs, or even more • human suffering caused to workers' families, which cannot be compensated with money.
<i>Employer</i>	<ul style="list-style-type: none"> • payment for work not performed; • medical and compensation payments; • repair or replacement of damaged machinery and equipment; • reduction or a temporary halt in production; • increased training expenses and administration costs; • possible reduction in the quality of work; • negative effect on morale in other workers. 	<ul style="list-style-type: none"> • the injured/ill worker has to be replaced; • a new worker has to be trained and given time to adjust; • it takes time before the new worker is producing at the rate of the original worker; • time must be devoted to obligatory investigations, to the writing of reports and filling out of forms; • accidents often arouse the concern of fellow workers and influence labour relations in a negative way; • poor health and safety conditions in the workplace can also result in poor public relations.

LEGISLATION

Government legislation is what provides workers with minimum standards of health and safety in the workplace. Minimum standards, however, can always be made more protective with stronger legislation. Historically, many trade unions have been successful in pressuring governments to enact health and safety legislation, to make legislation more protective and to enforce the laws. Today it is still important for unions to organize and fight for stronger and more protective occupational health and safety legislation at the national, state or provincial levels.

Workers, industry officials, health professionals and government officials all have responsibilities for health and safety.

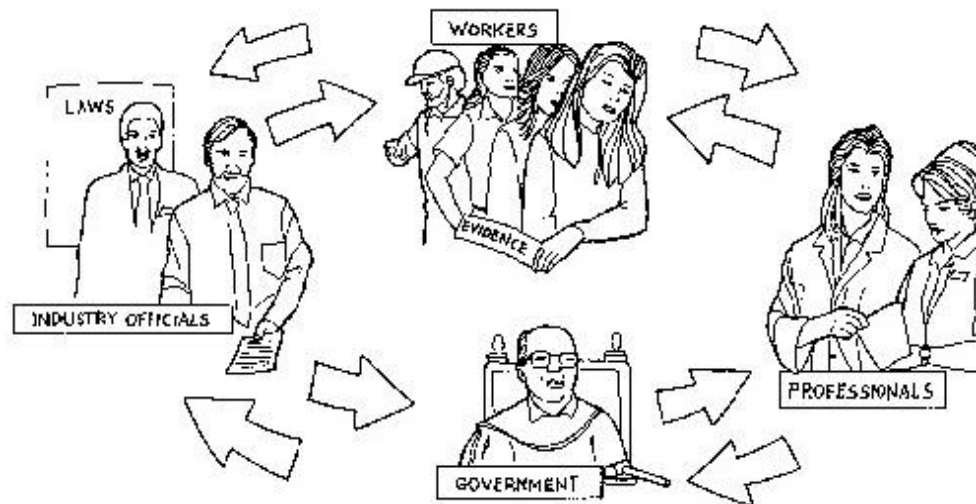

How legislation is structured

The terms used in health and safety legislation may vary in different countries. However, there are some common international terms that you may see in your country's legislation. Four of these terms are: **act, regulation, code of practice, guide.**

Act

Acts are fully supported by law, therefore potentially they have a great deal of power, but generally that power is only effective with adequate enforcement.

Regulations

Once a health and safety act is passed, then a minister (usually the Minister of Labour), the Cabinet or the state, provincial or even national government will develop detailed regulations. Regulations are fully supported by law so **employers are required to comply with them**, just like the overall act which they accompany.

Codes of practice

Codes of practice provide general guidance to employers (and workers) on how to comply with the minimum standards and objectives that are detailed in the regulations.

Guides

Guides or notes of guidance provide official detailed technical information and recommendations to help employers comply with health and safety regulations. Guides provide practical “how-to” information for getting into compliance.

THE OHS RECORDS

It's not good enough just to comply with OHS laws – employers must be in a position to prove that they comply. The following are the list of records which might help the employer to provide safe systems of work and safe worksite.

1. Operating manuals and maintenance records for plants and equipments.
2. Risk assessments and hazard identification processes.
3. Records of instruction and training of managers, supervisors, employees and contractors about their obligations to take reasonable care of themselves and others.
4. Records of induction and regular refreshers courses for managers, supervisors, employees and contractors
5. Emergency response manuals allocating responsibility for incident notification, management, legal advice and stakeholder relations

ERGONOMIC DESIGN



When you think about how to improve a workstation, remember this rule: **If it feels right, it probably is right. If it feels uncomfortable, there is probably something wrong with the design, not the worker.**

Two examples of good workstations

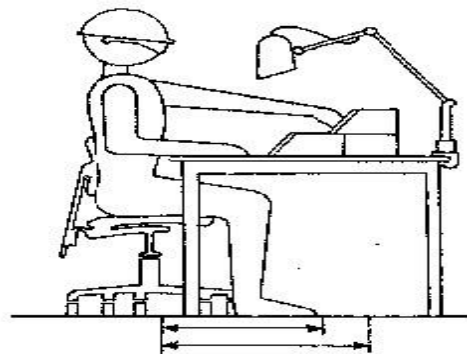
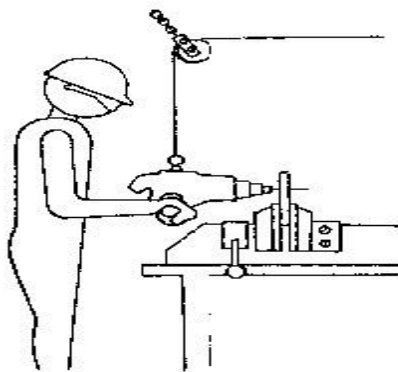

**On some jobs
arm supports
and rests may
reduce arm
fatigue**

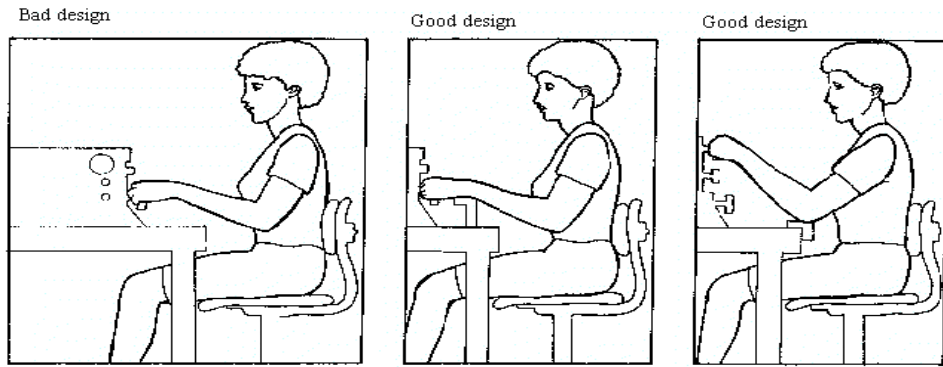

Use a padded WRIST rest or a padded ELBOW rest

The working position should be as comfortable as possible. The arrows indicate areas that need to be improved to prevent potential injuries from developing. To improve the sitting position for the worker on the right, the chair height should be lowered, tilted slightly forward and the worker should be provided with a footrest.

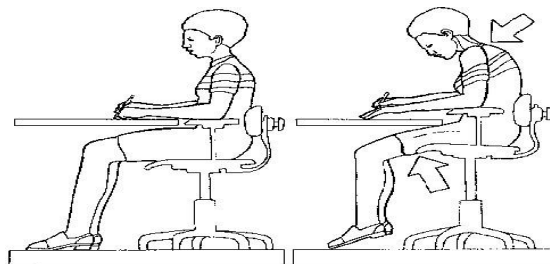

**The job should be designed to allow
the worker to keep the arms low and
the elbows close to the body**

***A chair, footrest, a mat to stand
on, and an adjustable work
surface are essential components
for a standing workstation***

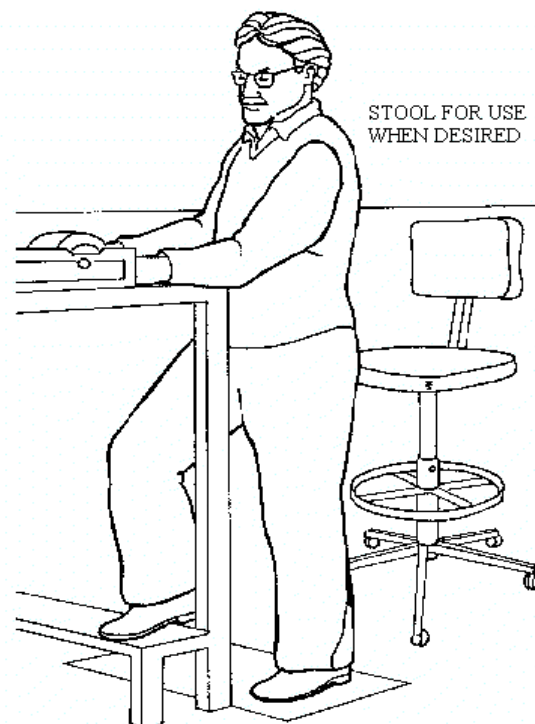

These pictures illustrate how tool design can prevent you from having to work with a bent wrist

BAD DESIGN

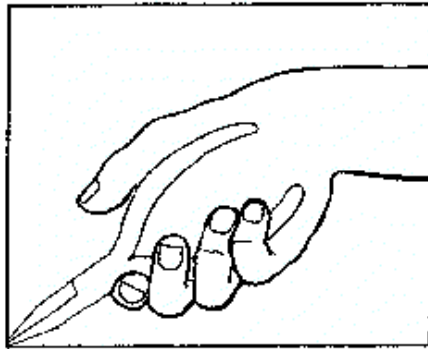

GOOD DESIGN

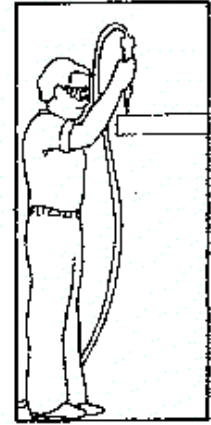
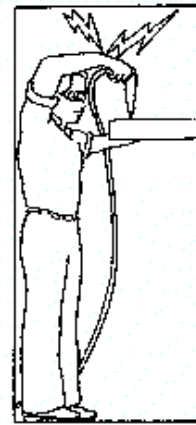
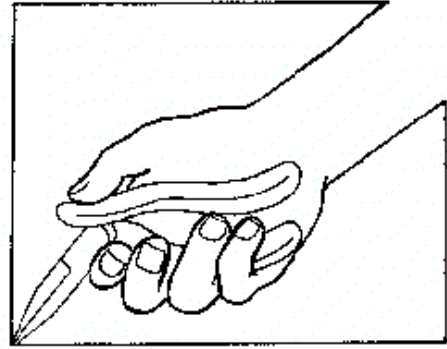

IN SOME CASES TOOLS CAN BE CHANGED TO KEEP THE ARMS LOW AND ELBOWS IN
BAD DESIGN



SOLDERING IRON WITH BENT HANDLE ALLOWS ELBOW TO BE LOWERED AND WRIST STRAIGHTENED
GOOD DESIGN





How Much Have You Learned?

Self-Check 2.1

Task: Find these words in the grid below

acid	deaf	fuel	ladder	power	solvents
bending	decibel	gas	lift	roof	strain
chemical	depth	glue	loud	scaffold	switch
climb	electrocution	heavy	noisy	shock	trip
current	Earplug	hoist	poison	slip	trolley

C	Y	R	R	A	C	E	A	R	P	L	U	G
H	E	A	V	Y	E	T	F	K	O	D	F	L
E	D	I	C	A	L	B	R	R	C	O	T	O
M	C	U	R	R	E	N	T	O	A	O	F	U
I	G	W	D	E	C	I	B	E	L	Y	H	D
C	H	O	I	S	T	R	A	I	N	L	E	S
A	D	H	E	F	R	C	D	B	F	A	E	D
L	L	P	I	S	O	L	V	E	N	T	S	Y
H	O	L	I	V	C	P	A	N	G	L	U	E
C	F	X	Q	R	U	M	O	D	E	P	T	H
T	F	U	E	L	T	U	K	I	D	J	B	N
I	A	Z	C	L	I	M	B	N	S	E	F	S
W	C	R	E	W	O	P	O	G	N	O	R	A
S	S	L	I	P	N	O	I	S	Y	T	N	G

Refer to the Answer Key. What is your score?



How Do You Apply What You Have Learned?

Show that you learned something by doing this activity.

Activity Sheet 2.1

Directions: Perform the following body movements and assess the area of hazard.

1. Exerting force while extending forearm
 - 1.1 Loosening and tightening screw.
 - 1.2 Driving a hammer.
 - 1.3 Operating a hand drill.
 - 1.4 Reaching an object forward.
 - 1.5 Reaching an object above the shoulder.
 - 1.6 Reaching behind the trunk.
 - 1.7 Lifting an object



How Well Did You Perform?

**Find out by accomplishing the Scoring Rubric honestly and sincerely.
Remember it is your learning at stake!**

- 100 % performance with 25% area of pain - Very satisfactory
75% performance with 50 % area of pain - Satisfactory
50% performance with 75 % area of pain - Good
25% performance with 75 % area of pain - Poor

WHAT IS YOUR SCORE? _____



How Do You Extend Your Learning?

Directions: Interview at least 3 Or 5 drivers and ask what part of his/her body easily gives in to pain when driving. Share your findings in the class.

LEARNING OUTCOME 3

Control Hazards and Risks

PERFORMANCE STANDARDS

- Procedures in dealing with workplace accidents, fire and emergencies and provision of appropriate assistance in the event of workplace emergencies are identified and followed in accordance with the organization's OHS policies.
- Personal Protective Equipment (PPE) is correctly used and maintained in accordance with organization's OHS procedures and practices.



Materials

- Video clips of hazard and risk
- Sample workstation



What Do You Already Know?

Let us determine how much you already know about controlling hazards and risks. Take this test.

Pretest LO 3

Directions: Select the best answer. Write the letter only in your Activity Notebook.

- Hazard identification must be conducted in close consultation with the _____ performing the activity.
A. animal B. person C. plant D. thing
- Once the hazards have been identified, the next step is to assess the _____.
A. game B. play C. risks D. time
- The _____ is the probability (likelihood) of harm or damage occurring from exposure to a hazard, and the likely consequences of that harm or damage.
A. damage B. destruction C. hazard D. risk
- Risk level can be _____, high, medium or low.
A. critical B. intentional C. logical D. magical
- The risk score at critical level is _____.
A. 1-2 B. 3-6 C. 8-14 D. 15-25

Criteria for Evaluating Results of Pre-Test

100% - skip the Learning Outcome and proceed to the next Learning Outcome

99% - below – Go through the Learning Outcome



What Do You Need To Know?

Read the Information Sheet 3.1 very well then find out how much you can remember and how much you learned by doing Self-check.

Information Sheet 3.1

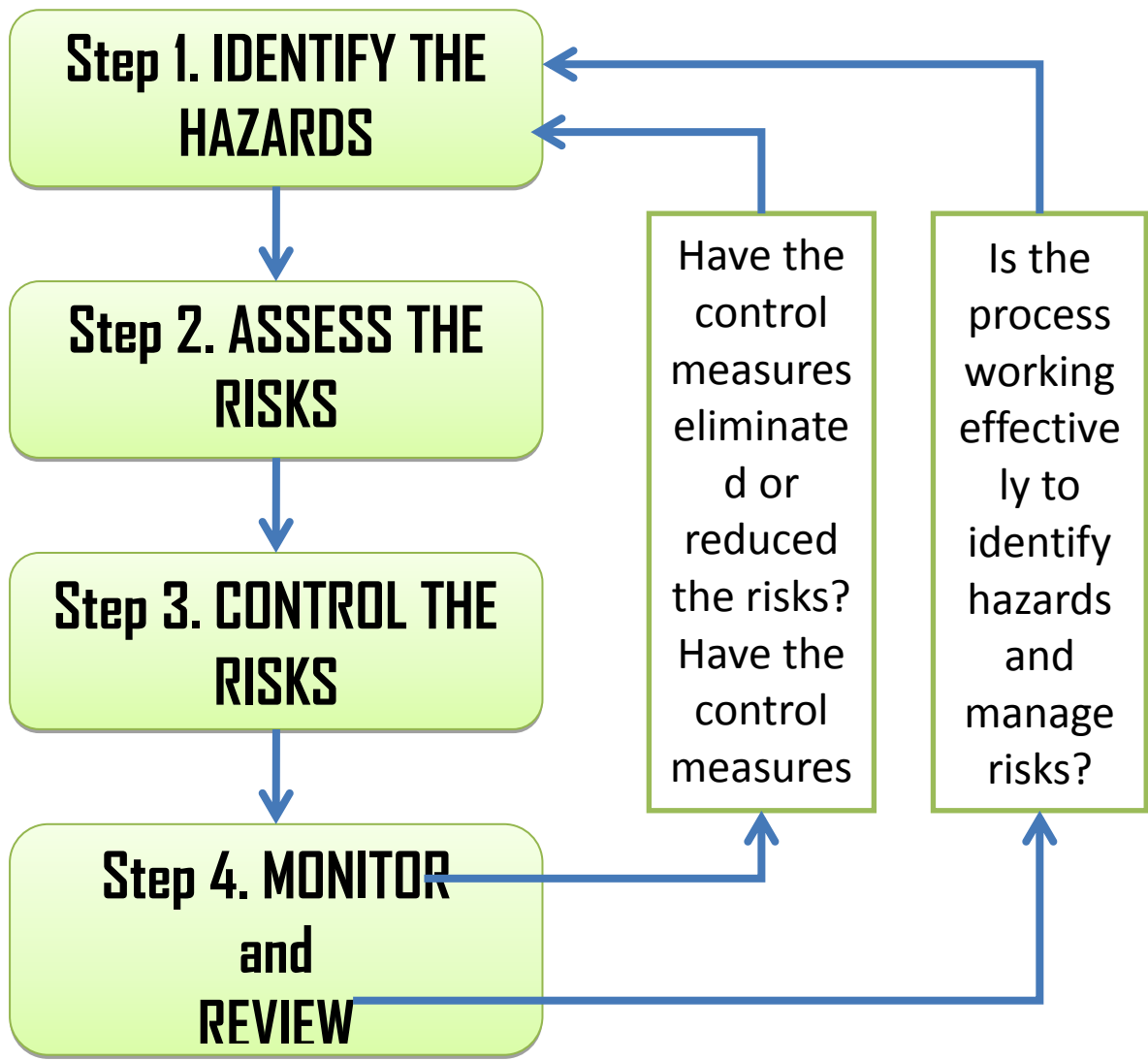

Step 1. IDENTIFY THE HAZARDS (LO 1)

This is the most important step in the risk management process. A hazard which is not identified cannot be controlled. Accordingly, it is crucial that this step is as comprehensive as possible. Hazard identification must be conducted in close consultation

with the people performing the activity. The following are used to assist staff to identify hazards in the workplace:

Based on your knowledge in identifying hazard you have learned from the **LO 1: Identifying Hazard and Risk**, complete the first two column (Identify Hazards and Location) on the table below

Identified Hazard	Location	Severity	Probability/Likelihood	Risk Score	Identified Control	Who Manage the Hazard	Date Completed

**Step 2. ASSESS THE RISKS
(LO 2)**

Once the hazards have been identified, the next step is to assess the risks. The Risk is the probability (likelihood) of harm or damage occurring from exposure to a hazard, and the likely consequences of that harm or damage. The greater the consequences, the greater the

risk, similarly the more certain the event, the greater the risk. Risk assessment is a process of analysis and evaluation.

Based on your knowledge you have learned from **LO 2: EVALUATE HAZARD AND RISK**, supply the necessary value for the next two column (Severity and probability). Refer your scoring on the equivalent value for Severity and Probability on the table below.

Value	Severity	Probability/Likelihood
1	Insignificant	Rare
2	Minor	Unlikely
3	Moderate	Possible
4	Major	Likely
5	Catastrophic	Almost Certain

The value of the **risk score** is equal to the product of Severity and Probability Values, to determine RISK LEVEL check the risk score with the table below

RISK LEVEL	RISK SCORE
CRITICAL	15 - 25
HIGH	8 - 14

MEDIUM	3 - 6
LOW	1 - 2

			consequence				
			Insignificant	Minor	Moderate	Major	Catastrophic
			1	2	3	4	5
Probability / Likelihood	Almost Certain	5	5	10	15	20	25
	Likely	4	4	8	12	16	20
	Possible	3	3	6	9	12	15
	Unlikely	2	2	4	6	8	10
	Rare	1	1	2	3	4	5

On the table above, the risk matrix will help identify the RISK SCORE and RISK LEVEL. Equivalently on the illustration below that encircled requires some attention.

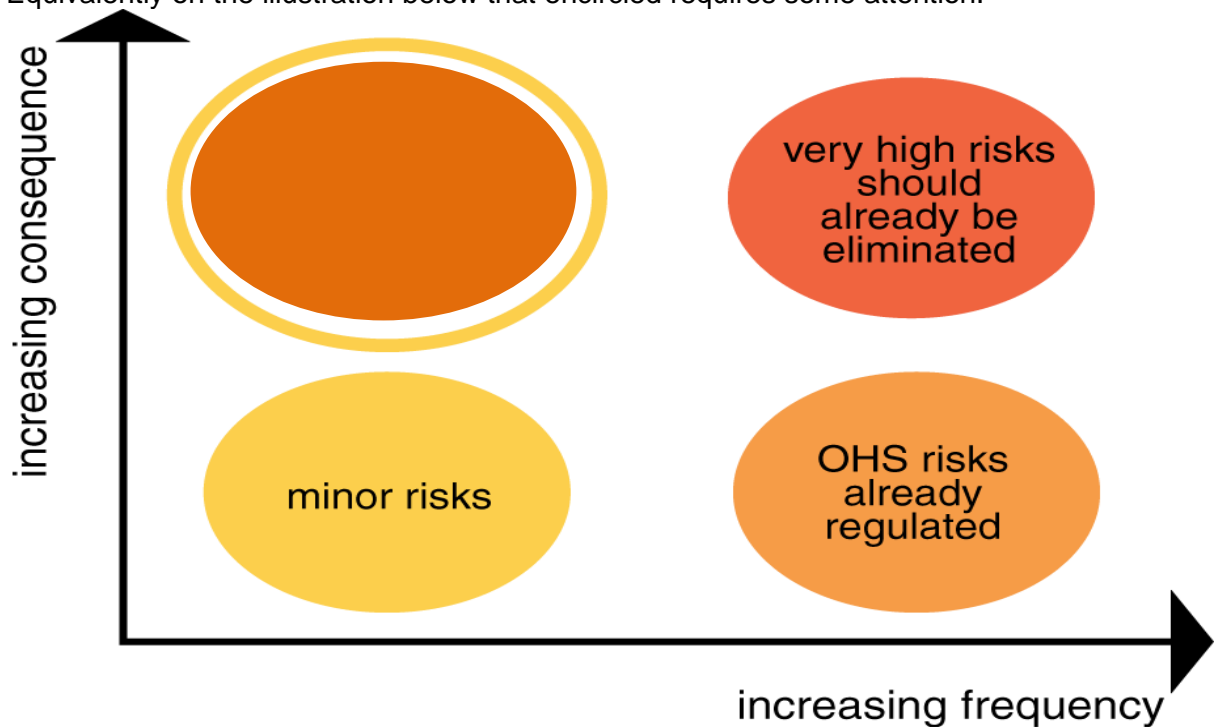

the focus of the major hazard facilities regulations is on the high consequence / low frequency incidents

Major accidents by their nature are rare events, which may be beyond the experience of many employers. These accidents tend to be low frequency, high consequence events as illustrated in Figure 1 below. However, the circumstances or conditions that could lead to a major accident may already be present, and the risks of such incidents should be proactively identified and managed.

Step 3. CONTROL THE RISKS

Risk Control must be achieved by using a predetermined hierarchy of controls. The primary aim of risk control is to eliminate the risk and the best way of achieving this is to remove the hazard. If this is not possible the risk must be minimized by using one or more of

the other control options from the hierarchy. The risk control measure selected must be the highest possible option within the hierarchy to minimize the risk to the lowest level as reasonably practicable. Existing controls should be re-evaluated to determine if the most appropriate control measure is in place. The hierarchy of controls includes:

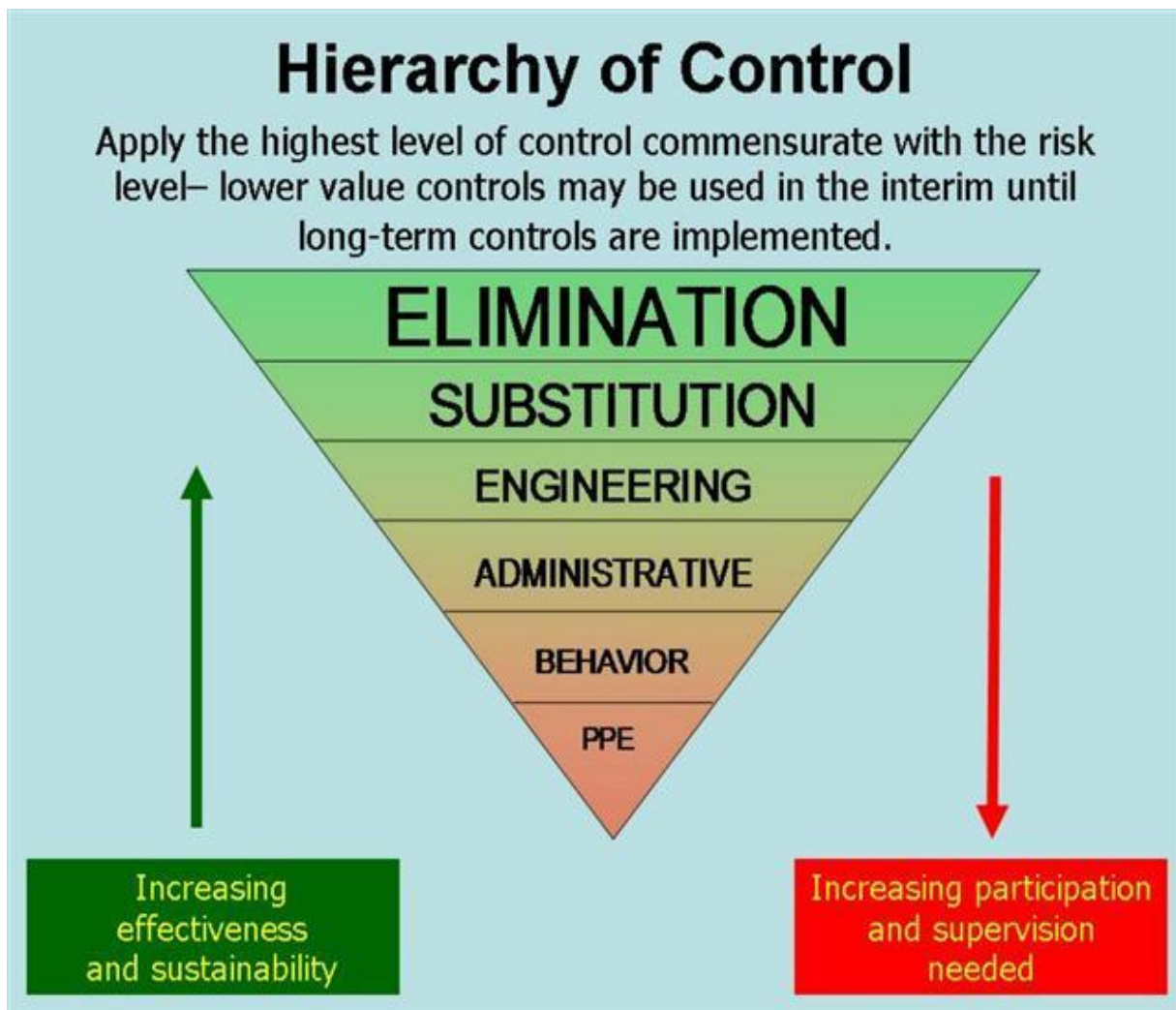

Preference	Control	Example
1.	Eliminate	Removing the hazard, eg taking a hazardous piece of equipment out of service.
2.	Substitute	Replacing a hazardous substance or process with a less hazardous one, eg substituting a hazardous substance with a non-hazardous substance.
3.	Isolation	Restricting access to plant and equipment or in the case of substances locking them away under strict controls.
4.	Engineering	Redesign a process or piece of equipment to make it less hazardous. Isolating the hazard from the person at risk, eg using a guard or barrier.
5.	Administrative	Adopting standard operating procedures (SOPs) or safe work practices or providing appropriate training, instruction or information.
6.	Personal Protective Equipment	The provision and use of personal protective equipment could include using gloves, glasses, earmuffs, aprons, safety footwear, dust masks.

Step 4. MONITOR and RFVIFW

Hazard management should be an ongoing and constantly improving process. To ensure the effectiveness in eliminating or minimizing risk, the process must be continuously reviewed and steps taken to implement revised control measures, where appropriate. It ensures that new hazards and those overlooked in the

original exercise are identified and controlled. The monitoring and review process involves:

- systematically checking existing risk control measures to assess their effectiveness;
- collecting data on any new hazards which have arisen;
- formulating new control measures.

Here are some general suggestions for an ergonomic workstation:

- Accommodate both right- and left-handed workers by providing a good work layout and tools which suit their needs.
- Provide each workstation with a chair even if the work is done standing up. Periodic rests and changes in body position reduce the problems of standing for too long.
- Eliminate glare and shadows. Good lighting is essential.

Points to remember about workstation design

1. The workstation is the place a worker occupies when performing a job.
2. A well designed workstation is important for preventing diseases related to poor working conditions, as well as for ensuring work is productive.
3. Every workstation should be designed with both the worker and the task in mind.
4. A properly designed workstation should allow the worker to maintain a correct and comfortable body posture.
5. There are a number of ergonomic factors to consider when designing a workstation, including head height, shoulder height, arm reach, elbow height, hand height, leg length, and hand and body size.

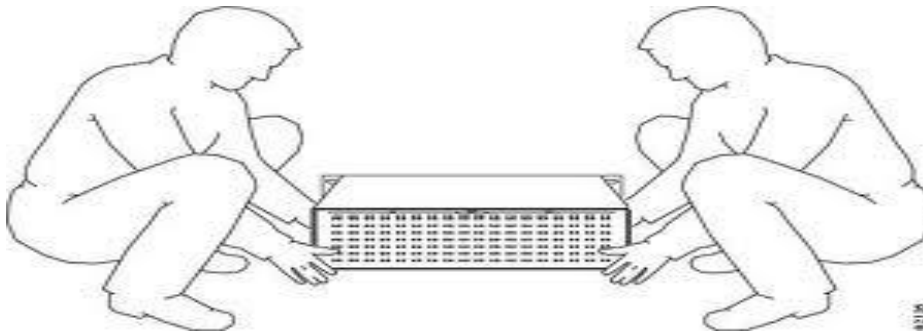

If lifting equipment is not available, the job may require a 'two-person lift'.



How Much Have You Learned?

Self-Check 3.1

Directions: Put a check (/) mark if “ I CAN” and an (X) if “ I CANNOT” on the corresponding competency.

Competency	I CAN	I CANNOT
1. Identify the hazards		
2. Assess the risks		
3. Control the risks		
4. Review and Monitor the hazards and risks		

Refer to the Answer Key. What is your score?



How Do You Apply What You Have Learned?

Show that you learned something by doing this activity.

Activity Sheet 3.1

Directions: Inspect the shop room. Make reports of the findings and apply necessary solutions to the problem. Be guided with the risks management process.

1. Identify the hazards.
2. Assess the risks.
3. Control the risks.
4. Monitor and review the hazards and risks.



How Well Did You Perform?

**Find out by accomplishing the Scoring Rubric honestly and sincerely.
Remember it is your learning at stake!**

Performance Rubrics

Criteria	5	3	1
Proficiency	Performs the task with competence and exceptional performance	Performs the task with competence and with standard performance	Performs the task with competence but below standard performance
Accuracy	Performs the task with no error	Performs the task with at least 1-2 errors	Performs the task with at least 3-5 errors
Completeness	Performs all the steps in sequence	Performs the task with at least 2-3 steps not met	Performs the task with at least 3-5 steps not met
Safety	Follows all the safety practices as set in the guidelines	Follows the safety practices with at least 1-2 safety measures not met	Follows the safety practices with at least 3-5 safety measures not met

TOTAL _____

RATING SCALE :

Points Earned (S)	Numerical Rating (PL)	Descriptive Rating (P)
21 – 25	91 - 100	Outstanding
16 – 20	86 - 90	Very Good
11 – 15	81 - 85	Good
06- 10	76 - 80	Fair
01- 05	71 - 75	Needs Improvement

WHAT IS YOUR SCORE? _____



How Do You Extend Your Learning?

Directions: Visit your nearest business industry and introduce yourself as automotive servicing student. Ask the owner/manager permission for you to observe how people work in relation to occupational hazards and risks. Discuss your observation in the class.

LEARNING OUTCOME 4

Maintain Occupational Safety and Awareness

PERFORMANCE STANDARDS

- Procedures in emergency related drills are strictly followed in line with the established organization guidelines and procedures.



Materials

- Sample sitting and chair design
- Video clips of heavy physical work
- Sample workstation in the shop



What Do You Already Know?

Let us determine how much you already know about maintaining occupational safety and awareness. Take this test.

Pretest LO 4

Directions: Select the best answer. Write the letter of your answer in your Activity Notebook.

1. Manual work must be _____ properly so that workers will not overexert themselves and develop muscle strain, especially in the back.
A. assigned B. designated C. designed D. resigned
2. Choose tools with an evenly balanced weight and make sure they are used in the proper
A. partition B. position C. precision D. promotion
3. Hand tools should be designed according to _____ requirements.
A. economic B. entrance C. ergonomic D. equal
4. Avoid holding a tool continuously in a _____ position or gripping a heavy tool to reduce muscle pain.
A. correct B. easy C. lax D. raised
5. When determining the appropriate height of the work surface, the following factors are considered except
A. the elbow height of the worker
B. the shape of tools and equipment being used
C. the size of the product being worked on
D. the type of work being performed

Criteria for Evaluating Results of Pre-Test

100%-skip the Learning Outcome and proceed to the next Learning Outcome

99%-below – Go through the Learning Outcome



What Do You Need To Know?

Read the Information Sheet 4.1 very well then find out how much you can remember and how much you learned by doing Self-check 4.1.

Information Sheet 4.1

GUIDELINES IN MAINTAINING OCCUPATIONAL SAFETY AND HEALTH AWARENESS

A. Sitting and Work chair design

- **Sitting**

If a job does not require a great deal of physical strength and can be done in a limited space, then the work should be done in a sitting position.

Note: sitting all day is not good for the body, especially for the back. Therefore, there should be some variety in the job tasks performed so a worker is not required to do sitting work only. A good chair is essential for sitting work. The chair should allow the worker to change the leg and general working positions easily.

The following are some ergonomic guidelines for sitting work:

- The worker needs to be able to reach the entire work area without stretching or twisting unnecessarily.
- A good sitting position means that the individual is sitting straight in front of and close to the work.
- The work table and the chair should be designed so that the work surface is approximately at the same level as the elbows.
- The back should be straight and the shoulders relaxed.
- If possible, there should be some form of adjustable support for the elbows, forearms or hands.

- **Work chair**

A proper work chair needs to satisfy certain ergonomic requirements. Use the following guidelines when choosing a chair:

- The work chair should be appropriate for the job being performed and for the height of the work table or workbench.

- Ideally the seat height and the backrest height should be adjustable separately. The backrest tilt should also be adjustable.
- The chair should allow the worker to lean forward or backward easily.
- The worker should have adequate leg room under the work table and should be able to change the position of the legs easily.
- The feet should be flat on the floor. When this is not possible, the worker should be provided with a footrest. A footrest will also help to eliminate pressure from the back of the thighs and knees.
- The chair should have a backrest which supports the lower back.
- The seat should curve slightly downward at the front edge.
- Ideally, the chair should have five legs for stability.
- It is preferable if arm rests are removable since some workers do not find them comfortable. In any case, arm rests should not prevent the worker from getting close enough to the work table.
- The chair should be covered with a breathable fabric to prevent slipping off the chair.

B. Standing workstation

Standing for long periods of time to perform a job should be avoided whenever possible. Long periods of standing work can cause back pain, leg swelling, problems with blood circulation, sore feet and tired muscles. Here are some guidelines to follow when standing work cannot be avoided:

- If a job must be done in a standing position, a chair or stool should be provided for the worker and he or she should be able to sit down at regular intervals.
- Workers should be able to work with their upper arms at their sides and without excessive bending or twisting of the back.
- The work surface should be adjustable for workers of different heights and for different job tasks.
- If the work surface is not adjustable, then provide a pedestal to raise the work surface for taller workers. For shorter workers, provide a platform to raise their working height.
- A footrest should be provided to help reduce the strain on the back and to allow the worker to change positions. Shifting weight from time to time reduces the strain on the legs and back.
- There should be a mat on the floor so the worker does not have to stand on a hard surface. A concrete or metal floor can be covered to absorb shock. The floor should be clean, level and not slippery.
- Workers should wear shoes with arch support and low heels when performing standing work.
- There should be adequate space and knee room to allow the worker to change body position while working.
- The worker should not have to reach to do the job tasks. Therefore the work should be performed 8 to 12 inches (20 to 30 centimeters) in front of the body.

When determining the appropriate height of the work surface, it is important to consider the following factors:

- the elbow height of the worker;
- the type of work being performed;
- the size of the product being worked on;
- the tools and equipment being used.

Follow these guidelines to ensure a good body position for standing work:

- Face the work.
- Keep the body close to the work.
- Move the feet to face in a new direction instead of twisting your back or shoulders.

C. Hand tools and controls

- ***Hand tools***

Hand tools should be designed according to ergonomic requirements. Poorly designed hand tools, or tools that do not fit the individual worker or the task can cause negative health effects and decrease a worker's productivity. In order to prevent health problems, as well as to maintain the worker's productivity, hand tools should be designed so that they fit both the individual **and** the task. Well designed tools can contribute to good body positions and movements and can increase productivity. Use the following guidelines when selecting hand tools:

- Avoid poor quality hand tools.
- Choose tools that allow the worker to use the larger muscles in the shoulders, arms and legs, rather than the smaller muscles in the wrists and fingers.
- Avoid holding a tool continuously in a raised position or gripping a heavy tool. Properly designed tools allow the worker to keep the elbows next to the body to prevent damage to the shoulder or arm. Additionally, properly designed tools do not require the worker to bend the wrists, stoop or twist.
- Choose handles that are long enough to fit the whole hand. This will help to reduce uncomfortable pressure on the palm of the hand or on the joints of the fingers and hand.
- Do not use tools with spaces where fingers and skin can get caught.
- Choose double-handled tools, such as scissors, pliers or clippers. These should have a span that does not overstretch the hand.
- Do not select tools with contoured handles; they fit only one size of hand and put pressure on hands they do not fit.
- Make tool handles easy to grip. Handles should also have good electrical insulation and they should not have any sharp edges or sharp corners. Put soft plastic covers on handgrips to reduce slipperiness.
- Avoid using tools that force the wrist to bend or to be in an awkward position. Redesign tools so that the tool bends and not the wrist.

Choose tools with an evenly balanced weight and make sure they are used in the proper

- Position.
- Make sure tools are properly maintained.
- Tools should be appropriate for right- or left-handed workers.

D. Heavy physical work

Manual work must be designed properly so that workers will not overexert themselves and develop muscle strain, especially in the back. Performing heavy physical work for long periods causes the rate of breathing and the heart beat to increase. If a worker is not in good physical condition, he or she is likely to get tired easily while doing heavy physical work. Whenever possible, it is helpful to use mechanical power to do the heavy work. This does not mean that employers should replace workers with machines, rather, that workers can use machines to perform the most arduous tasks. Mechanical power reduces the risks to the worker and at the same time provides more work opportunities for people with less physical strength. Use the following guidelines for designing jobs that require heavy physical work:

- Heavy work should not exceed the capacity of the individual worker.
- Heavy physical work should be varied throughout the day at regular intervals with lighter work.
- Rest periods must be included in the day's work.



How Much Have You Learned?

Self-Check 4.1

Directions: Below is a puzzle interconnected with one another. Give at least four (4) important guidelines in maintaining occupational safety and awareness. Use your Activity Notebook for your answers.

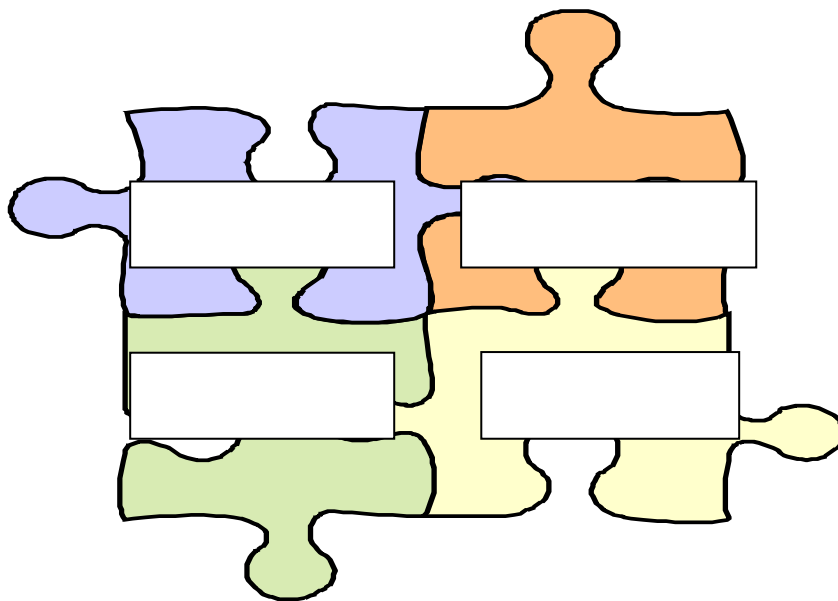

Refer to the Answer Key. What is your score?



How Do You Apply What You Have Learned?

Show that you learned something by doing this activity.

Activity Sheet 4.1

Directions: Answer the following competencies in the column below to assess your knowledge in Maintaining Occupational Safety and Awareness. Which of the following do you know about? Put a check (✓) on the appropriate box.

Maintaining Occupational Safety and Awareness	Yes	No
1. <i>Sitting and Work chair task</i>		
2. <i>Standing workstation</i>		
3. <i>Hand tools and controls</i>		
4. <i>Heavy physical work</i>		



How Well Did You Perform?

**Find out by accomplishing the Scoring Rubric honestly and sincerely.
Remember it is your learning at stake!**

Performance Rubrics

Criteria	5	3	1
Proficiency	Performs the task with competence and exceptional performance	Performs the task with competence and with standard performance	Performs the task with competence but below standard performance
Accuracy	Performs the task with no error	Performs the task with at least 1-2 errors	Performs the task with at least 3-5 errors
Completeness	Performs all the steps in sequence	Performs the task with at least 2-3 steps not met	Performs the task with at least 3-5 steps not met
Safety	Follows all the safety practices as set in the guidelines	Follows the safety practices with at least 1-2 safety measures not met	Follows the safety practices with at least 3-5 safety measures not met

TOTAL _____

RATING SCALE:

Points Earned (S)	Numerical Rating (PL)	Descriptive Rating (PL)
21 – 25	91 - 100	Outstanding
16 – 20	86 - 90	Very Good
11 – 15	81 - 85	Good
06 - 10	76 - 80	Fair
01 - 05	71 - 75	Needs Improvement

WHAT IS YOUR SCORE? _____



How Do You Extend Your Learning?

1. Make a parallel evaluation of your household furniture/equipment in relation with the one use in the workshop in terms of:
 - a. Ergonomic design
 - b. Safety
2. Discuss your findings in the class



Congratulations! You did a great job! Rest and relax a while then move on to the next lesson. Good luck!

REFERENCES

LO1

- Workplace hazards and risks
<http://jessicawebber.hubpages.com/hub/Hazards-and-Risks-in-the-Workplace>
- Hazard Identification, Risk Assessment and Risk Control
<http://www.education.vic.gov.au/safe@work/modules/general/risks.asp>
- Hazard and Risk - Canadian Centre for Occupational Health and safety
http://www.ccohs.ca/oshanswers/hsprograms/hazard_risk.html
- Hazard - Wikipedia
http://www.ccohs.ca/oshanswers/hsprograms/hazard_risk.html
- **AEF Companies Crane Safety and Preventive Measures**
<http://www.aefcompanies.com/safety.htm>
- **PROTECT YOUR HEARING!!! – IMPACT CIL**
<http://impact.books.officelive.com/ProtectYourHearing.aspx>
- **Your health and safety at work - YOUR BODY AT WORK – International Labour Organization**
<http://actrav.itcilo.org/actrav-english/telearn/osh/body/bmain.htm>

LO 2

INTERNATIONAL LABOR ORGANIZATION

- <http://actrav.itcilo.org/actrav-english/telearn/osh/legis/lemain.htm>
The Legal informant
- <http://johnhodgkinson.wordpress.com/2010/10/20/ohs-record-keeping/>

LO 3

- Swing Crispin, Frederic, Dictionary of Technical TermsThe Bruce Publishing Co.:1948.
- Chilton's Easy Car Care. Chilton Book Company. 3rd Ed. Chilton Way, Radnor, PA 19089
- Stockel, Martin W. Auto mechanics Fundamentals. The Goodheart - Willcox Company, Inc. 1978
- The Oxford Dictionary of Current English. New Revised Ed. Oxford University Press, 1998.
- Popular Mechanics Guide To Auto Basic Repair and Maintenance. Book Division The Hearst Corporation, New York, NY

REFERENCES

LO 4

- Workplace hazards and risks
<http://jessicawebber.hubpages.com/hub/Hazards-and-Risks-in-the-Workplace>
- Hazard Identification, Risk Assessment and Risk Control
<http://www.education.vic.gov.au/safe@work/modules/general/risks.asp>
- Hazard and Risk - Canadian Centre for Occupational Health and safety
http://www.ccohs.ca/oshanswers/hsprograms/hazard_risk.html
- Hazard - Wikipedia
http://www.ccohs.ca/oshanswers/hsprograms/hazard_risk.html
- **AEF Companies Crane Safety and Preventive Measures**
<http://www.aefcompanies.com/safety.htm>
- **PROTECT YOUR HEARING!!! – IMPACT CIL**
<http://impact.books.officelive.com/ProtectYourHearing.aspx>
- **Your health and safety at work - YOUR BODY AT WORK – International Labour Organization**
<http://actrav.itcilo.org/actrav-english/telearn/osh/body/bmain.htm>

ANSWER KEYS

LESSON1. USE OF HANDTOOLS

ANSWER KEYS

LO 1. Plan and Prepare for Tasks to be Undertaken.

PRE TEST

1. A - careful and proper
2. A - confidence
3. B - safety
4. C - loosening and tightening tools
5. B - measuring tools

SELF-CHECK #1.1

1. B d C ▲
2. B e C ▼
3. B a C ►
4. B b C ▲
5. B c C ◄

LO 2. Prepare and Use Hand tools.

PRE TEST

1. D – tools
2. C – identify and select
3. B – practice
4. C – injury
5. A – checking and inspection

SELF-CHECK #2.1

1. f
2. c
3. e
4. j
5. g
6. d
7. a
8. h
9. b
10. i

LO 3. Create Report of Malfunctioning Hand Tools

PRE TEST

1. A - effectiveness
2. A - frequently
3. C - marked
4. C - serviceability
5. D - reduces

SELF-CHECK #3.1

1. Assess self-reflection on Minute Paper

LO4. Maintain Hand tools

PRE TEST

1. **Self-Assessment**

SELF-CHECK

1. Check self reflection on Minute Paper

LESSON2. PERFORM MENSURATION AND CALCULATION

ANSWER KEYS

LO 1. Select Measuring Instrument and Carry out Measurement and Calculations

PRE TEST

1. C- measuring tool
2. B- hit and miss
3. D- vernier caliper
4. A- manual
5. D-torque
6. A-backlash
7. C-tolerance
8. D-strobe light
9. A- formula
10. A-kilometer (km)

SELF-CHECK #1.1

I.

1. B - dishonesty
2. D- scientific
3. A- foot
4. A- kilometer (km)
5. B- 212°F

II.

A. MECHANICAL USE

1. Vernier caliper
2. Micrometer caliper
3. Dial gauge

B. ELECTRICAL/ELECTRONICS USE

1. V.O.M. Tester
2. Clamp ammeter
3. Megger tester
4. Engine analyzer
5. Strobe/Timing light

C. PNEUMATIC USE

1. Vacuum gauge
2. Compression gauge
3. Radiator pressure tester

D. HYDRAULIC USE

1. Fuel pressure gauge
2. Oil pressure gauge
3. Temperature gauge

E. Check Personal Reflection

LO2. Maintain Measuring instruments

PRE TEST

A. Why a measuring instruments get out of calibration?

1. Low charge/ discharge battery
2. Miscarriage/ sudden, heavy impact
3. Accidental drop
4. Accidental use
5. Unprotected covering

B. Basic rules to consider in managing your measuring instruments.

1. Always keep your receipt of purchase
2. Always follow safety instructions.
3. Always match the type of job with your instruments.
4. Always handle your measuring instruments safely.
5. Always store in safe and clean place

SELF-CHECK # 2.1

A. Why a measuring instruments get out of calibration?

1. Low charge/ discharge battery
2. Miscarriage/ sudden, heavy impact
3. Accidental drop
4. Accidental use
5. Unprotected covering

B. Basic rules to consider in managing your measuring instruments.

- a. Always keep your receipt of purchase
- b. Always follow safety instructions.
- c. Always match the type of job with your instruments.
- d. Always handle your measuring instruments safely.
- e. Always store in safe and clean place

LESSON3. INTERPRETING PLANS AND DRAWINGS

ANSWER KEYS

LO 1. ANALYZE SIGNS, SYMBOLS AND DATA

PRE TEST

A.

1. C
2. D
3. B
4. A
5. A
6. B.
7. C
8. A
9. B
10. A

B.

1. F
2. A
3. C
4. B
5. E

SELF- CHECK #1.1

1. B
2. C
3. C
4. B
5. A
6. B
7. A
8. B
9. A
10. B

SELF- CHECK #1.2

A. IDENTIFICATION:

1. NO PARKING
2. KEEP LEFT
3. SPEED LIMIT
4. NO U-TURN
5. CHILDREN AHEAD

B. CLASSIFICATION:

1. Information
2. Warning
3. Regulatory
4. Warning
5. Regulatory

SELF-CHECK #1.3

A.

1. A
2. B
3. D
4. B
5. D

B.

1. A
2. D
3. B
4. C
5. B

LO2. Interpret Technical Drawings and Plans

PRE TEST

1. D. Plan
2. B. semi schematic
3. A. pictorial diagram

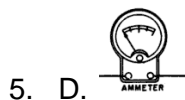
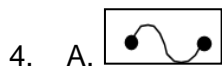

6. B. drawing
7. D. schematic

8. A. layout diagram
9. C. ground
10. B. technical drawing
11. D. battery
12. C. bulb
13. C. horn
14. B. motor
15. A. relay

SELF- CHECK #2.1

1. D
2. E
3. B
4. C
5. A

SELF- CHECK #2.2

Matching Type:

1. D
2. A
3. B
4. E
5. F

Draw and Identify:

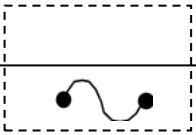
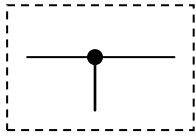
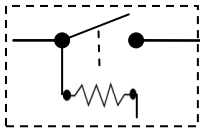
1. Fuse 
2. Connection 
3. Relay 

LESSON4. PERFORM SHOP MAINTENANCE

ANSWER KEYS

LO 1. *Inspect/Clean Tools, Materials and Shop Equipment*

PRE TEST

1. B - mistakes
2. A - caught by the machine
3. A - hard shoes or boots with rubber soles.
4. C - scratch machines or car finishes.
5. D - all of the above

SELF-CHECK #1.1

I

1. A - workshops
2. C - safety
3. C – followed
4. A – protective
5. C – person-in-charge

II

1. A - kept clean and free of dust and oil or grease.
2. A - marked as defective
3. C - returned to the tool room or put back in their drawers, cabinets or racks.
4. C - kept closed.
5. A - get lost.

III

1. S – Strong alkali
2. S – Strong acid
3. H – Heavy duty alkali
4. M – Mild acid
5. S – Soft acid

LO 2. *Store/Arrange Tools, Materials and Shop Equipment*

PRE TEST

1. C - others
2. D – well-ventilated
3. C – upper body
4. A – habits
5. D – protect
6. C – gloves
7. B – face mask
8. A – signs
9. D – symbols
10. C – personal safety

SELF-CHECK # 2.1

I

1. D - protect
2. D - self
3. A - habits
4. C - upper body protection
5. D - well-ventilated

II

1. A - These are the ones that need sustainable training in the shop and workshop environment.

2. D - having uniform procedures of work or placement of things in proper place.

3. B - management of workshop facilities like the tools, materials, equipment / machineries

including facilities like furniture, lighting, water, and furniture.

4. C - maintaining a continuous and consistent implementation of doing the 5 S.

5. E - making things easy to see, easy to get, and easy to return.

LO 3. Dispose Waste/Used Lubricants

PRE TEST

1. A - harmful effects
2. A - managed
3. A - waste materials
4. B - good
5. A - compliance
6. B - environment
7. B - lubricating
8. C - reactive
9. D - lethal
10. A - condition

SELF-CHECK # 3.1

6. A – waste materials
7. A – compliance
8. C – harmful effects
9. B – good
10. C - managed

LESSON 5: PRACTICE OCCUPATIONAL HEALTH AND SAFETY PROCEDURES

LO 1. IDENTIFY HAZARDS AND RISKS

PRE TEST

1. D – work
2. C – six
3. C – thing
3. B – fumes
4. C – labeled

SELF-CHECK # 1.1

1. B. hazard
2. A. risk
3. C. dormant
4. C. corrosive materials
5. B. asbestos
6. C. noise
7. A. biohazardous infectious materials
8. B. flammable and combustible material
9. B. solvents
10. D. compressor

Crossword Puzzle

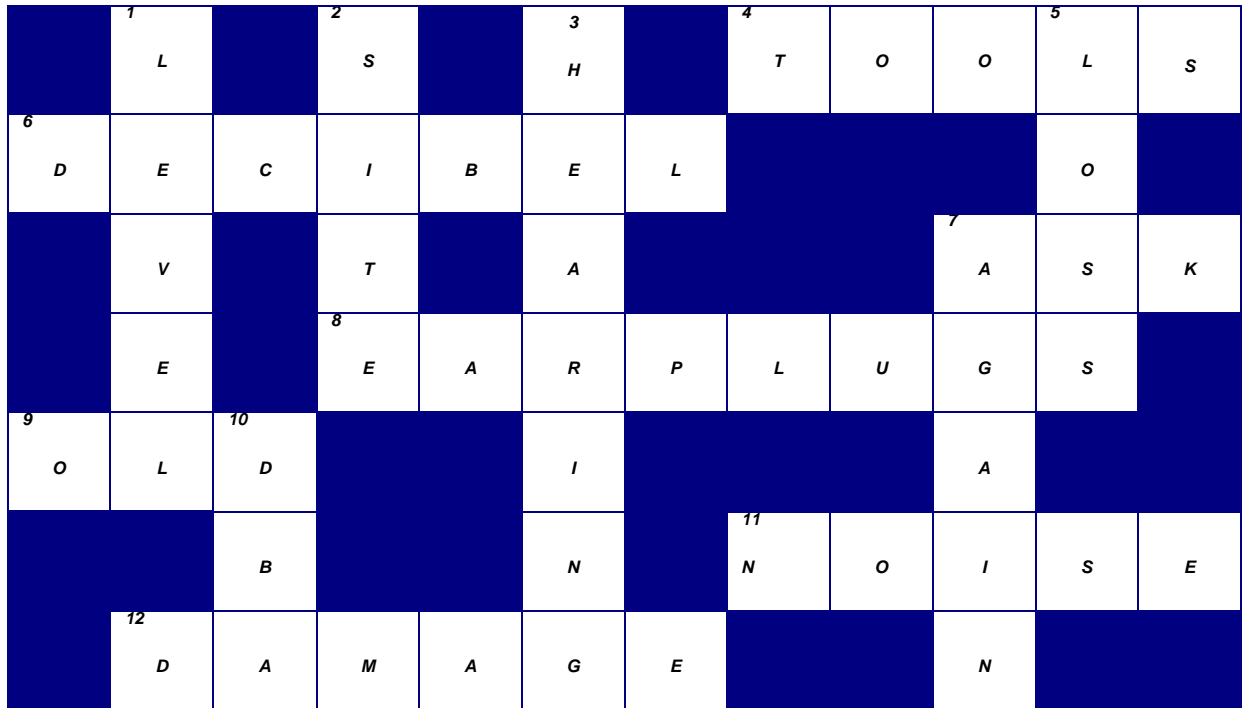

LO2. EVALUATE HAZARDS AND RISKS

PRE TEST

1. B - stress
2. A – heart disease
3. C – musculoskeletal disorder
4. B – wrist pain
5. A - elbow
6. C – neck and shoulder
7. C – neck and shoulder
8. D - allergies
9. A - legislation
10. B – stress, act, regulation, code of practice and guide

SELF-CHECK # 2.1

Task: Find these words in the grid below

acid	deaf	fuel	ladder	power	solvents
bending	decibel	gas	lift	roof	strain
chemical	depth	glue	loud	scaffold	switch
climb	electrocution	heavy	noisy	shock	trip
current	earplug	hoist	poison	slip	trolley

C	Y	R	R	A	C	E	A	R	P	L	U	G
H	E	A	V	Y	E	T	F	K	O	D	F	L
E	D	I	C	A	L	B	R	R	C	O	T	O
M	C	U	R	R	E	N	T	O	A	O	F	U
I	G	W	D	E	C	I	B	E	L	Y	H	D
C	H	O	I	S	T	R	A	I	N	L	E	S
A	D	H	E	F	R	C	D	B	F	A	E	D
L	L	P	I	S	O	L	V	E	N	T	S	Y
H	O	L	I	V	C	P	A	N	G	L	U	E
C	F	X	Q	R	U	M	O	D	E	P	T	H
T	F	U	E	L	T	U	K	I	D	J	B	N
I	A	Z	C	L	I	M	B	N	S	E	F	S
W	C	R	E	W	O	P	O	G	N	O	R	A
S	S	L	I	P	N	O	I	S	Y	T	N	G

LO3. CONTROL HAZARDS AND RISKS

PRE TEST

1. B - person
2. C - risks
3. D - risks
4. A - critical
5. D – 15-25

SELF-CHECK # 3.1

1. Check Self-Reflection

LO4. OCCUPATIONAL SAFETY AND AWARENESS

PRE TEST

1. C - designed
2. B - position
3. C - ergonomic
4. D – raised
5. B - the shape of tools and equipment being used

SELF-CHECK # 4.1

1. Sitting and Work chair design
2. Standing workstation
3. Hand tools and controls4. Heavy physical work

Acknowledgement

This Learning Module was developed for the Exploratory Courses in Technology and Livelihood Education, Grades 7 and 8 of the K to 12 Curriculum with the assistance of the following persons:

This Learning Module on **Automotive Servicing NC I** was developed by the following personnel:

MODULE WRITERS

ROBERTO S. DAQUIL

Head Teacher VI DepED-Manila

REVIEWERS

GIL P. CASUGA

Chief TESD Specialist

REYNALDO S. DANTES

Senior TESD Specialist

MARIA A. ROQUE

Senior TESD Specialist

BERNADETTE S. AUDIJE

Senior TESD Specialist

VICTORIO N. MEDRANO

Principal IV, SPRCNHS

PARALUMAN R. GIRON, Ed.D.

Chair, Sub-TWG on K to 10

BRENDA B. CORPUZ, Ph.D.

TA for K to 12 Curriculum

OFELIA O. FLOJO

Retired Assistant Chief, EED, Region IV-A

BEATRIZ A. ADRIANO

Principal IV, ERVHS

AIDA T. GALURA

VSA II, ACNTS

DOMINGA CAROLINA F. CHAVEZ

Principal II, MBHS

DOCUMENTORS /SECRETARIAT

PRISCILLA E. ONG

K to 12 Secretariat

FREDERICK G. DEL ROSARIO

Head Teacher III, BNAHS

EMMANUEL V. DIONISIO

Head Teacher III, AFGBMTS

LYMWEL P. LOPEZ

Teacher I, AFGBMTS

DANTE D. VERMON JR.

Teacher I, AFGBMTS

CHERLYN F. DE LUNA

Teacher I, AFGBMTS

JOANNA LISA C. CARPIO

Teacher I, BNAHS

ROMANO T. LOPEZ

Teacher I, BNAHS

Dir. IMELDA B. TAGANAS

*Executive Director, Qualifications Standards Office
K to 12 Learning Area Team Convenor, TLE/TVE*