



Republic of the Philippines
DEPARTMENT OF EDUCATION



K to 12 Basic Education Curriculum Technology and Livelihood Education Learning Module



HORTICULTURE

EXPLORATORY COURSE

Grade 7 and Grade 8

TABLE OF CONTENTS

What Is This Module About ?	2
How Do You Use This Module	3
LESSON 1 – Use Farm Tools and Equipment	4 - 42
LESSON 2 – Perform Estimation and Basic Calculation	43 - 87
LESSON 3 – Interpret Plans and Drawings	88 - 119
LESSON 4 – Apply Safety Measures in Farm Operation	120 - 142
ANSWER KEYS	143 - 149
Acknowledgment.....	150



What Is This Module About?

Welcome to the world of **Horticulture!**

This Module is an exploratory course which leads you to **Horticulture** National Certificate Level II (NC II)¹. It covers four common competencies that a Grade 7 / Grade 8 Technology and Livelihood Education (TLE) student like you ought to possess, namely:

- 1) Use and maintenance of tools/equipment;
- 2) Estimation and basic calculation;
- 3) Interpretation of plans and drawings; and
- 4) Safety precautions in farm operations.

These four common competencies are covered separately in four Lessons. As shown below, each Lesson is directed to the attainment of one or two learning outcomes:

Lesson 1 –Use Farm Tools and Equipment

- LO1. Select and use farm tools
- LO 2. Select and operate farm equipment
- LO 3. Perform preventive maintenance

Lesson 2 – Perform Estimation and Basic calculation

- LO 1. Perform estimation
- LO 2. Perform basic workplace calculations

Lesson 3 – Interpret Plans and Drawings

- LO1. Interpret farm plans and lay-outs
- LO2. Interpret irrigation plan and design

Lesson 4 – Apply Safety Precautions in Farm Operations

- LO 1. Apply appropriate safety measures while working in the farm
- LO 2 Safe keep / dispose tools, materials and outfit

Your success in this exploratory course in **Horticulture** will be shown in your ability to come up with the performance standards set for each Lesson.

¹**NATIONAL CERTIFICATE (NC)** is a certification issued to individuals who achieved all the required units of competency for a national qualification as defined under the Training Regulations. NCs are aligned to specific levels within the PTQF. (TESDA Board Resolution No. 2004-13, Training Regulations Framework)

NATIONAL CERTIFICATE LEVEL refers to the four (4) qualification levels defined in the Philippine TVET Qualifications Framework (PTQF) where the worker with:

- a. NC I performs a routine and predictable tasks; has little judgment; and, works under supervision;
- b. NC II performs prescribe range of functions involving known routines and procedures; has limited choice and complexity of functions, and has little accountability;



How Do You Use This Module?

This Module has four Lessons. Each Lesson has the following parts.

- Learning Outcomes
- Performance Standards
- Materials
- References
- Definition of Terms
- What Do You Already Know?
- What Do You Need to Know?
- How Much Have You Learned?
- How Do You Apply What You Learned?
- How Well Did You Perform?
- How Do You Extend Your Learning?

To get the most from this Module, you need to do the following:

1. Begin by reading and understanding the Learning Outcome/s and Performance Standards. These tell you what you should know and be able to do at the end of this Module.
2. Find out what you already know by taking the Pretest then check your answer against the Answer Key. If you get 99 to 100% of the items correctly, you may proceed to the next Lesson. This means that you need not go through the Lesson because you already know what it is about. If you failed to get 99 to 100% correctly, go through the Lesson again and review especially those items which you failed to get.
3. Do the required Learning Activities. They begin with one or more Information Sheets. An Information Sheet contains important notes or basic information that you need to know.

After reading the Information Sheet, test yourself on how much you learned by means of the Self-check. Refer to the Answer Key for correction. Do not hesitate to go back to the Information Sheet when you do not get all test items correctly. This will ensure your mastery of basic information.

4. Demonstrate what you learned by doing what the Activity / Operation /Job Sheet directs you to do.
5. You must be able to apply what you have learned in another activity or in real life situation.
6. Accomplish the Scoring Rubrics for you to know how well you performed.

Each Lesson also provides you with references and definition of key terms for your guide. They can be of great help. Use them fully.



If you have questions, ask your teacher for assistance.

LESSON 1

Use Farm Tools and Equipment



LEARNING OUTCOMES:

At the end of this Lesson you are expected to do the following:

- LO 1. select and use farm tools;
- LO 2. select and operate farm equipment; and
- LO 3. perform preventive maintenance.



Definition of Terms

Equipment – is a powered machine used in farming

Farm implements - are accessories pulled by animals or mounted on a machinery to make the work easier

Hand tools – are objects that are usually light and are used without the help of animals and machines

Preventive maintenance – is an activity or operation done to prevent malfunction of tools and equipment and prolong the useful life of tools and equipment

Repair – is an act to restore to good condition something broken or damaged

LEARNING OUTCOME 1

Select and use farm tools

PERFORMANCE STANDARDS

- Appropriate farm tools should be identified according to requirements /use.
- Farm tools should be checked for faults and defective tools are reported in accordance with farm procedures.
- Appropriate tools and equipment should be safely used according to job requirements and manufacturers conditions.



Materials

- Bolo
- Pick-mattock
- Spade
- Rake
- Light hoe
- Hand cultivator
- Pruning shears
- Knife
- Water pails
- Wheel barrow
- Plow
- Rotavator
- Crowbar
- Grab-hoe
- Shovel
- Spading fork
- Hand trowel
- Hand fork
- Axe
- Sprinklers
- Sprayers
- Sickle
- Harrow



What Do You Already Know?

Find out how much you already know about the use of farm tools. Take this test.

Pretest LO 1

Read the questions carefully and select the best answer by writing only the letter of your choice on a separate sheet of paper.

1. Which of the following is an example of a digging tool?
 - A. Bolo
 - B. Crowbar
 - C. Grub hoe
 - D. Pruning shear
2. Which tool is used for cutting grass?
 - A. Shovel
 - B. Bolo
 - C. Crowbar
 - D. Mattock
3. What tool does NOT belong to the group?
 - A. Crowbar
 - B. Mattock
 - C. Shovel
 - D. Pruning shear
4. Farm tools are very important in pre-horticultural operations because they _____
 - A. make work easier
 - B. make work faster
 - C. save time and effort
 - D. all of the above
5. A tool with one end of its blade flattened and the other pointed at right angles to its handle is a _____.
 - A. mattock
 - B. crowbar
 - C. bolo
 - D. spade
6. Which tool resembles the appearance of a spoon and is used for transferring soil?
 - A. Spade
 - B. Shovel
 - C. Spading fork
 - D. Grub hoe

7. What implement is being pulled by a working animal to till the land?
 - A. Harrow
 - B. Native plow
 - C. Disc plow
 - D. Disc harrow
8. An implement attached to a tractor that is used to pulverize the newly plowed soil is a_____
 - A. trailer
 - B. disc harrow
 - C. native plow
 - D. disc plow
9. An open container with a single wheel at the front and two handles at the back used to transport things is a_____
 - A. hand tractor
 - B. tractor
 - C. basket
 - D. wheel barrow
10. Which of the following tools is used to harvest crops?
 - A. Knife
 - B. Plow
 - C. Spade
 - D. Basket



What Do You Need To Know?

Read the Information Sheet 1.1 Find out how much you can remember and how much you have learned by doing Self-check 1.1.

Information Sheet 1.1

FARM TOOLS IN HORTICULTURAL OPERATION

Farm tools, implements, and equipment play very important role in horticultural operations. Their availability makes the work much easier and faster. However, even if one may have the most sophisticated tools and implements, but does not know how to use them, they are useless. In order to do horticultural operations successfully, one must have a good working knowledge of the tools, implements and equipment before using them.

Hand Tools



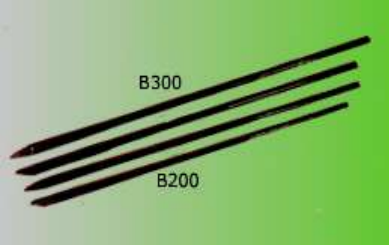

Hand tools are usually light and are used without the help of animals or machines. They are being used in performing farm activities which involve small areas like school garden and home garden.

Examples:

<p>A Bolo is used for cutting tall grasses and weeds and chopping branches of trees.</p>	
<p>A Crowbar is used for digging big holes and for digging out big stones and stumps.</p>	

<p>A Pick-mattock is used for digging canals, breaking hard topsoil and for digging up stones and tree stumps.</p>	
<p>A Grab-hoe is used for breaking hard topsoil and for pulverizing soil.</p>	
<p>A Spade is used for removing trash or soil, digging canals or ditches, and mixing soil media.</p>	
<p>A Shovel is used for removing trash, digging loose soil, moving soil from one place to another and for mixing soil media.</p>	
<p>A Rake is used for cleaning the ground and leveling the topsoil.</p>	

<p>A Spading fork is used for loosening the soil, digging out root crops and turning over the materials in a compost heap.</p>	
<p>A Light hoe is used for loosening and leveling soil and for digging out furrows for planting</p>	
<p>A Hand trowel is used for loosening the soil around the growing plants, and putting small amount of manure fertilizer in the soil.</p>	
<p>A Hand cultivator is used for cultivating the garden plot by loosening the soil and removing weeds around the plant.</p>	
<p>A Hand fork is used for inter-row cultivation.</p>	

<p>A Pruning shears is for cutting branches of planting materials and unnecessary branches of plants.</p>	
<p>An Axe is used for cutting a bigger size post.</p>	
<p>A Knife is for cutting planting materials and for performing other operations in horticulture</p>	
<p>Sprinklers are used for watering seedlings and young plants</p>	
<p>Water pails are used for hauling water, manure and fertilizers</p>	

Sprayers are used to spray insecticides, foliar fertilizers, fungicides and herbicides



A **Wheel barrow** is used for hauling trash, manures, fertilizers, planting materials and other equipment.



A **Sickle** is a hand-held agricultural tool with a variously curved blade typically used for cutting weeds.



Farm Implements

These are accessories that are being pulled by working animals or mounted to machineries (hand tractor, tractor); which are usually used in the preparation of land. These are usually made of a special kind of metal.

Examples are:

1. **Plows.** These are farm implements used in horticultural operations either pulled by a working animal or a tractor. The plow is specifically used for tilling large areas, making

furrows and inter-row cultivation. Plows pulled by working animals are made of either a combination of metal or wood or pure metal. They are used to till areas with a shallower depth than that of the disc plows; which are pulled by tractors.

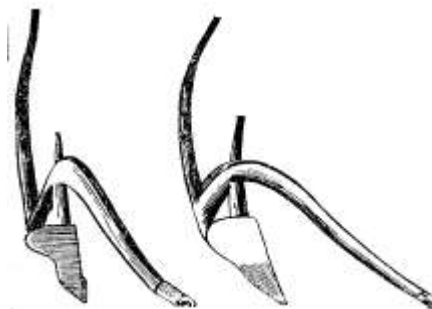

Native plow



Disc plow

2. **Harrow.** The native wooden harrow is made of wood with metal teeth; and pulled by a carabao while the disc harrow is made of metal mounted to a tractor. Harrows are used for tilling and pulverizing the soil.



Native wooden harrow



Disc harrow

3. **Rotavator.** The rotavator is an implement attached to a tractor used for tilling and pulverizing the soil

DEFECTS AND HAZARDS WITH FARM TOOLS

Although there are many different types of tend to have similar characteristics and parts, such as:

- cutting edges,
- gears,
- chains,



ASSOCIATED

farm machinery, they

- levers,
- revolving shafts, and
- rotating blades.

The main hazards associated with exposure to these parts are described below.

Shear/Cutting Points

1. Shear points are created when the edges of two objects are moved close enough together to cut a material, as in the case of a pair of shears or an auger.
2. Cutting points are created when a single object moves forcefully or rapidly enough to cut, as in the case of a sickle blade.
3. They are hazards because of their cutting force, and because they often move so rapidly that they may not be visible.
4. Workers should be aware of shear points, and shields or guards should be used to prevent exposure or access.

Pinch Points

1. Pinch points are formed when two objects move together and at least one of them is moving in a circle. For example, the point at which a belt runs onto a pulley is a pinch point. Belt drives, chain drives and gear drives are other examples of pinch points in power transmission devices.
2. Body parts such as fingers, hands and feet can be caught directly in pinch points, or they may be drawn into the pinch points by loose clothing that becomes entangled.
3. Workers should be aware of pinch points, and shields or guards should be used to prevent exposure or access.

Wrap Points

1. Rotating shafts are the most common source of wrap point accidents, although any exposed tool part that rotates can be a wrap point. Clothing or hair can catch on a rotating part.
2. The ends of shafts that protrude beyond bearings are also dangerous. Universal joints, keys and fastening devices can also snag clothing.
3. Entanglement with a wrap point can pull you into the machine, or clothing may become so tightly wrapped that you are crushed or suffocated.
4. Workers operating machinery should be aware of wrap points and wear clothing that will not become entangled in moving components. In addition, where possible, shields or guards should be used to prevent access.

Crush Points

1. Crush points are created when two objects move toward each other or one object moves toward a stationary one. For example,
 - failure to block up tool safely can result in a crushing injury.
2. Crushing injuries most commonly occur to fingers. To prevent a crushing injury, workers should:
 - be aware of crush points and avoid potentially dangerous situations;

- arrange the hitch point so that a tool can be backed into position without a worker being in the path;

Pull-In Points

1. Pull-in points usually occur when plant material or other obstacles become stuck in feed rolls or other tool parts, preventing the mechanism from operating

Springs

1. Springs are commonly used to help lift equipment such as shock absorbers, and to keep belts tight and may harbour potentially dangerous stored energy.
2. Springs under compression will expand with great force when released while those that are stretched will contract rapidly when released.
3. A worker should know in which direction a spring will move and how it might affect another tool part when released, and stay out of its path.

GENERAL FARM TOOL SAFETY

Keeping tools in good working condition is half the formula for being safe. The other half is the ability and awareness of the person using the tools

Safety = Good Working Tools + Able and Aware Worker

Tool failure causes some farm accidents; however, most farm accidents are caused by tired, stressed, rushed, distracted, or incompetent workers.

In addition to the specific safe handling rules for each type of farm tools, there are ten basic guidelines for tools safety:

- Read and comply with the operator's safety manual for each piece of farm tool.
- Prepare for safety by wearing appropriate clothing, having enough rest, not drinking alcohol, and ensuring that all workers have been trained and are capable of safely using the farm tool.
- Keep all guards, shields, and access doors in place when the tool is in used
- Be aware of what you are doing and where you are going.
- Adjust tool to fit working conditions.
- Keep children and other people away from the working area.
- Take breaks from work, as necessary.



How Much Have You Learned?

Self-Check 1.1

Matching Type: Match column A to Column B

- | | |
|------------------------|---|
| _____ 1. Sprinkler | A. used for spraying insecticides, foliar fertilizers, fungicides and herbicides |
| _____ 2. Knife | B. used for hauling water, manure and fertilizers |
| _____ 3. Hand Fork | C. used for watering seedlings |
| _____ 4. Bolo | D. used for cutting planting materials |
| _____ 5. Rake | E. used for leveling the top soil |
| _____ 6. Shovel | F. used for removing trash, digging loose soil, moving soil from one place to another and for mixing soil media |
| _____ 7. Pruning Shear | G. used for cutting bigger size post |
| _____ 8. Sprayer | H. used for cutting branches of planting materials and unnecessary branches of plants |
| _____ 9. Pail | I. used for inter-row cultivation |
| _____ 10. Axe | J. used for cutting tall grasses and weeds and chopping branches of trees |

Refer to the Answer Key. What is your score?



How Do You Apply What You Learned?

Show that you learned something by doing this activity

Activity Sheet 1.1

DEMONSTRATING THE USE OF FARM TOOLS

Farm Tools:

- Land preparation tools
- Cultivation tools
- Plant propagation tools
- Harvesting Tools

Instructions:

The trainee will do the following instructions.

1. Make a list of farm tools used in:
 - land preparation
 - cultivation
 - plant propagation
 - harvesting
2. Write the functions of each tool.
3. Compile the listings in one folder and submit to your teacher.

After submission trainee will perform the following instructions:

1. Select and identify the tools in land preparation and demonstrate its use.
2. Select and identify the tools in cultivation and demonstrate its use.
3. Select and identify the tools in plant propagation and demonstrate its use.
4. Select and identify the tools in harvesting and demonstrate its use.



How Well Did You Perform?

**Find out by accomplishing the Scoring Rubric honestly and sincerely.
Remember it is your learning at stake!**

While performing the activity it is important that you to assess your performance following the criteria below:

Criteria	Score			
	20	15	10	5
List of tools are completed				
Function of tools are correctly stated				
Appropriate farm tools are identified and selected according to requirements/use				
Farm tool checked for faults and defective tools are reported in accordance with farm procedures				
Appropriate tools are safely used according to job requirements and manufacturers' conditions.				

Interpretation of Scores:

16 – 20 – Excellent output

11 – 15 – Very good

6 – 10 – Fair output

5 and below – Poor output



How Do You Apply What You Learned?

Show that you learned something by doing this activity

Operation Sheet 1.1

Introduction:

Shovel is used for different farm operation. It is used for digging soil, moving soil from one place to another, cleaning ditches, etc. Proper use of this tool can help user to make the work easier.

PPE and Tools needed:

- Footwear
- Long pants
- Gloves
- Rag
- Shovel

Procedure:

Follow these instructions. Make sure that you are wearing appropriate personal protective equipment; before you perform this activity.

1. Keep feet wide apart. Place front foot close to the shovel.



2. Put your weight on front foot. Use your two hands to push shovel.



3. Shift weight to the rear foot.
Keep load close to your body.



4. Turn feet in the direction of throw



5. Perform housekeeping.

Digging Procedures

1. Push spade down using leg muscle



2. Slide load close to body.
Ensure load is loose from ground before lifting





How Well Did You Perform?

Find out by accomplishing the Scoring Rubric honestly and sincerely. Remember; it is your learning at stake!

While performing the activity it is important that you to assess your performance following the criteria below:

Criteria	Score			
	20	15	10	5
Proper distance of your feet from each other				
The weight should be on front foot				
The load should be close to your body				
Direction of your feet when throwing load				
Practice good housekeeping				

Interpretation of Scores:

16 – 20 – Excellent output

11 – 15 – Very good

6 – 10 – Fair output

5 and below – Poor output

LEARNING OUTCOME 2

Select and operate farm equipment

PERFORMANCE STANDARDS

- Appropriate farm equipment and facilities are identified.
- Instructional manual of farm equipment are carefully read prior to operation.
- Pre-operation check-up is conducted in line with manufacturers' manual.
- Faults in farm equipment and facilities are identified and reported in line with farm procedures.



Equipment

- Hand Tractor
- Four Wheel Tractor
- Water Pump



What Do You Already Know?

Let us determine how much you already know about the use of farm equipment. Take this test.

Pretest LO 2

ANSWER THE FOLLOWING:

1. Define what is an equipment.(4 points)
2. Give the specific uses and function of the following equipments:
 - A. Hand tractor (3 points)
 - B. Four wheel tractor (3 points)
 - C. Water pump (3 points)



What Do You Need To Know?

Read the Information Sheet 2.1 Find out how much you can remember and how much you have learned by doing the Self-check 2.1.

Information Sheet 2.1

COMMON FARM EQUIPMENT

These are machineries used in horticultural operations, especially in vegetable production. They are used in land preparation and in transporting farm inputs and products. This equipment needs a highly skilled operator to use.

A **Hand tractor** is used to pull a plow and harrow in preparing a large area of land.

A **Four wheel tractor** is used to pull disc plow and disc harrow in preparing much bigger area of land.

Water pumps are used to draw irrigation water from a source.



Hand Tractor



Four Wheel Tractor



Water Pump

Courtesy of Alcala Rural School

HAND TRACTOR SPECIFICATION



<http://jonathanong.sulit.com.ph>

Specification—

1. The tillage blade can add the ground-break blade for cultivating the hard land (black soil).
2. Using the Japanese engine is heavy duty and use for long time.
3. Joinable blade : depend on the working demand to adjust the width of the cultivation .

ENGINE :

2 Cycle Gasoline -- Made in Japan

Type :	ROBIN - EC08 3.3 HP / 5500 rpm	Engine Weight : 7.6 KG
Ignition :	Electronic	
Start Mode :	Recoil Starter	
Fuel Tank :	1.5 liter	
The Device :		
Operation Mode	Rear-drag type	
Forward Mode	The device moves forward by the rotary blades	
Transmission Mode	Driving shaft going through worm-gear speed reducer operate centrifugal clutch	
Transfer Mode	Easy carry by hand / shoulders / car ,do not affect by the landform circumstance	
Width of tillage	26-74cm (joinable tillage blade)	
Depth of tillage	28cm (adjustable)	
Weight	25kg (not including 6-rotary tillage blade)	

Included ACCESSORIES : tillage blade and tool bag , each in one set

FARM EQUIPMENT PARTS AND FUNCTIONS

Understanding the Various Controls on the Tractor

• Starting the Tractor

- The Kubota and most small farm tractors are started by turning the key to the right one click until the light for the glow plugs comes on and then goes off again.
- You may then depress the clutch and turn the key all the way to the right until the engine turns over.
- On cold mornings the choke may be required. This is operated by pulling the choke (located near the key) all the way out. As you turn the engine over, slowly push the choke back in until the engine kicks on.
- It is very important that the throttle be pushed all the way in the upward (turtle) position before starting the tractor. This gives the tractor an opportunity to warm up in the idle position, which is very important for any diesel engine.

• Throttle Control

- The throttle can be located sticking out of right side of the dash. It is an orange handled lever equipped with a turtle and a rabbit symbol.
- Pulling down on the lever towards the rabbit increases the amount of fuel fed into the engine and therefore increases RPM's and available power to the tractor.

• Clutch Pedal

- This pedal is found on the left side of your foot controls. It is a single pedal.

• Forward and Reverse Pedal

- This “rocker” pedal makes the tractor go forwards and backwards and can be found on the right side of your foot controls. It sits on the floor of the tractor.

• Brake Pedals

- These pedals sit above the “rocker” pedal and can be operated as one pedal or split to brake the individual rear wheels

Understanding the various parts of a small farm tractor and their functions

• PTO (power take off)

- A PTO is used for powering a tiller, auger, or any other implement that is actively driven by the tractors engine.
- The PTO can be located in the back of the tractor.
- Hooking up the PTO drive shaft to the PTO and running the engine so the tachometer reads 540 RPM's use the PTO.
- To engage the PTO the clutch must be depressed. Once the clutch is depressed you may shift the PTO lever forward and then slowly release the clutch pedal to begin spinning the PTO. The lever can be found next to your right hip on the tractor.
- It is important when engaging the PTO not to “shock load.” A “shock load” happens when the clutch is popped and the engine is revved to a running RPM level. “Shock loading” the PTO stresses the metal on the tractor and the implement being driven. To avoid this, run the tractor's engine with the lowest RPM's possible when taking your foot off the clutch and engaging the implement.

- **Three-Point Hitch Hydraulic**

- The hydraulic unit and three-point hitch system is designed to raise and lower the implement positioned on the rear of the tractor.
- The hydraulic is used to determine the operating depth of both active (PTO driven) and passive implements. This will determine the depth of tillage, subsoil ripping, plowing, etc of any given implement in use.
- The lever that controls the three-point hitch can be found on the right side of the tractor driver's body around the height of the knee.
- If the lever is pushed towards the ground at maximum depth the implement will be forced down as far as it may go by the hydraulics of the tractor.

- **Front Bucket Loader**

- The front bucket loader is used for scooping large loads and moving heavy objects or masses of earth around the farm.
- The front bucket loader is hydraulically operated using the ball lever located on
- the right hand side of the tractor directly across from the tractor driver's shoulder.
- There are two different ranges of motion available to you when using the front loader.
- The arm of the bucket may be raised or lowered and the bucket may be tilted forward and backward.
- The controls are "reversed" in that to make the arm of the bucket come up, you pull down on the ball lever. To lower the arm, you push up on the ball lever.
- To dump the bucket, you move the ball lever to your right. To tilt the bucket back, you move the ball lever to your left.
- These are the four main movements of the ball lever. Each movement is accomplished by moving the lever in the primary directions (north, south, east and west).
- There are four other movements that incorporate both ranges of motion simultaneously. In other words, they move the arm and the bucket at the same time. These movements can be found by engaging the ball lever at the secondary directions (i.e., southwest, northeast, etc). These movements require more skill and experience and will make your movements more fluid.

Basic Tractor Safety Principles

- Always wear your seatbelt! Most tractors are equipped with a roll over protection device that
- is built to protect you if the tractor rolls. A seatbelt will save you from getting crushed!
- Never stand near a spinning PTO! The PTO and connected drive shaft spins with incredible
- force. Keep clothing and body parts away from the spinning shaft, or risk dismemberment and death!
- Do not rest arms or hands in the joints of any hydraulic part! Or risk dismemberment.
- Never put your hands inside or around active implements when the tractor is running!
- Turn off tractor if any jamming or other obstructions occur when using PTO driven implements.
- Do not operate tractor on a dangerous slope! Be aware of rollover dangers.
- Always move very slowly when moving heavy loads in the bucket! Driving with a heavy
- load greatly changes the balance and stability of the tractor. Heavy loads encourage tipping and rolling.

How to Operate a Farm Tractor

Knowing how to drive farm tractor properly can help avoid accidents. Using the tractor in the farm reduces the tedious work and eventually offers more time enjoying other activities.

In this sense, you should know the safety precautions when using the farm tractor.



Improper use of farm tractor is one of the major causes of deaths related to farm works. According to study, almost 800 people died every year because of tractor accidents and other s re injured. There are several ways of tractor accident such as falls of both the operators as well as extra riders. That is why if you are using the farm tractor during the cropping months make sure that you have the proper knowledge in operating the equipment.

Know the Operation

Before you decide to let anyone operate the farm tractor you need to ensure that the individual knows how to operate the machine. Never let anyone operate the tractor without proper training otherwise it might lead to accident. It is vital to follow the safety rule to ensure that the operator is physically fit, trained and qualified to operate the farm tractor. To ensure safety a new operator can practice using the farm tractor without attaching the equipment. Make sure that you have at least one member of the family who is trained to operate the tractor. In this way, the trained individual can assist other individuals in operating the machine. Proper demonstration of the procedure is necessary as well as explains how each element of the machine operates. On the other hand, after the demonstration the trainer should allow the new operator to operate the machine. Yet close supervision is required and give instructions when needed.

Pre-Operation Checkup

Maintenance Inspection

Before operating the farm tractor see to it to check first if it works well. Keep in mind that there are many factors that alter the safety and reliability of the machine. That is why it is essential to perform pre-operational check up to ensure safe operation. Keeping the tractor in good working condition can help prevent possible accidents. Ensure to keep always at hand the operating manual. See to it that each operator should read and understand the information written the manual. By following the operating precautions as well as following the recommendations, accidents will be avoided. Likewise, the operator should wear the appropriate clothing and gears when operating the farm tractor.

Safe refueling

Another accident that is associated to farm tractor is fire and explosions. Keep in mind that when refueling there is a great risk as you will handle gasoline. As a safety measure, you should never refuel the machine while the engine is running. Otherwise, static electricity would generate a spark and worst lead to fire. To reduce the static electricity, you should drop a mounted wire in the equipment to the ground.



How Much Have You Learned?

Self-Check 2.1

ANSWER THE FOLLOWING:

1. Define equipment. (4 points)
2. Give the specific uses and function of the following equipments:
 - A. Hand tractor (3 points)
 - B. Four wheel tractor (3 points)
 - C. Water pump (3 points)



How Do You Apply What You Learned?

Show that you learned something by doing this activity

Activity Sheet 2.1

SCRAPBOOK ON FARM EQUIPMENT

Introduction:

After learning about the different farm equipment, you will be compiling pictures of farm equipment which includes an instructional manual.

Materials needed:

Procedure:

1. Collect pictures of various farm equipment and instructional manual. You may clip pictures from the internet.
2. For the pictures taken from online sites, copy the URL and paste it below the pictures.
3. Cut the pictures and paste them to a short bond paper
4. Search the uses or functions of this equipment and write them below or beside the pictures.
5. If the instructional manuals are available, paste it in another bond paper.
6. Compile the sheets in one folder and submit them to your teacher.

OPERATING THE FARM EQUIPMENT

Introduction:

Given the available farm equipment, the trainee will be able to operate this equipment following the given instructions and the trainee will be observed and assessed by the trainer using the performance standard reflected in the scoring rubrics.

Equipment:

Any of the following equipment or farm equipment suggested by the trainer is acceptable in performing this operation.

- Hand Tractor
- Four Wheel Tractor
- Water Pump

Instructions:

1. Read the operation manual of the selected equipment carefully.
2. Identify the parts and operation controls and explain its functions in the presence of the expert/trainer.
3. Conduct inspection using the pre-operation check up manual.
4. Make the inspection report and indicate the action to be taken.
5. Correct and remedy the equipment trouble as instructed by the expert/trainer.
6. Ask permission from the authorized personnel to operate the equipment.



How Well Did You Perform?

**Find out by accomplishing the Scoring Rubric honestly and sincerely.
Remember it is your learning at stake!**

For Activity 2.1

Criteria	Score			
	20	15	10	5
Completeness				
Well organized				
Neatness				
Updated				

For Operation 2.1

Criteria	Score			
	20	15	10	5
Instructional manual of farm equipment are carefully read prior to operation.				
Appropriate farm equipment and operation controls are identified and functions are explained.				
Pre-operation check-up is conducted in line with manufacturers' manual				
Faults in farm equipment and facilities are identified and reported in line with farm procedures				
Farm equipment are safely operated according to its function				

Interpretation of Scores:

16 – 20 – Excellent output

11 – 15 – Very good

6 – 10 – Fair output

5 and below – Poor output

LEARNING OUTCOME 3

Perform preventive maintenance

PERFORMANCE STANDARDS

- Tools and equipment are cleaned immediately after use in line with farm procedures.
- Routine check-up and maintenance are performed.
- Tools and equipment are stored in designated areas in line with farm procedures.
- Farm tools and equipment are regularly sharpened and oiled from time to time.



Materials Tools &

- Bolo
- Pick-mattock
- Spade
- Rake
- Light hoe
- Hand cultivator
- Pruning shears
- Knife
- Water pails
- Wheel barrow
- Plow
- Rotavator
- Hand Tractor
- Four Wheel Tractor
- Water Pump
- Crowbar
- Grab-hoe
- Shovel
- Spading fork
- Hand trowel
- Hand fork
- Axe
- Sprinklers
- Sprayers
- Sickle
- Harrow



What Do You Already Know?

Determine how much you already know about performing preventive maintenance on farm tools and equipment. Take this test.

Pretest LO 3

TRUE OR FALSE: Read and analyze each statement below. Write True if the statement is correct; False if the statement is incorrect on the space provided for.

1. It is not advisable to use the stone in a stabilized way.
2. Tools that are worn out should be separated and fixed immediately to avoid accident.
3. When sharpening, try to maintain the original factory bevel or angle
4. Always push the file across the blade in a motion away from your body
5. Clean accumulated rust and dirt off all metal surfaces with paint.
6. Move the file diagonally, so that its cutting teeth are biting into the metal on the tool.
7. Use medium-grit sandpaper to remove rust on larger tools such as shovels, spades, and hoes.
8. When sharpening with a file, use oil.
9. Oil helps tool to work as intended and will prevent the formation of rust.
10. For pruners, use a whetstone because it produces a very sharp cutting edge.



What Do You Need To Know?

Read the Information Sheet 3.1 Find out how much you can remember and how much you have learned by doing Self-check 3.1.

Information Sheet 3.1

PRE-OPERATIVE CHECK UP OF FARM TOOLS, IMPLEMENTS AND EQUIPMENTS

Imagine that the long, hot summer vacation has finally come to an end, it's the beginning of the school year, and you are ready to start working your vegetable gardens. But before that, let us check first our tools, implements and equipment.

Use your working clothes and your personal protective equipment (PPE). Proceed to the shop to retrieve your tools so that you can start clearing away the last remnants of

summer, and begin breaking the soil for a new year. Imagine your frustration as you start pulling out all of your tools to see that they are covered with rust, and dirt and crusty globs of oil that have collected dust last vacation. It seems that you are going to spend more time cleaning and repairing tools more than you will actually use them.

How to Clean Your Garden Tools:

Let's start with the basics. Your shovel, spade, hoe, or even the blades on a hedge trimmer will be a lot easier to use if you take a few minutes to knock some of the rust off the blade. Not only will this extend the life of the tool, but also cut through the soil better, requiring less effort to use. It is a good idea to keep a large whetstone in your shop. A whetstone is an ideal tool to use, to keep all of the cutting edges of your garden tools honed. It will work well on your shovel, as well as many other common garden tools.

The best way to use the stone is to find a way to stabilize the tool that you want to work on. A bench vise is ideal. You will be able to clamp the tool into place at an angle, so you can work on it. Clamping the garden tool into place with a vise frees both of your hands to use the whetstone, and gives you more control over what you are doing.

Apply a little lubricating oil at the end of the tool, and carefully begin to work the stone over the blade. Maintain a 30-degree angle between the stone and the blade to form the ideal cutting edge for your tool. Not only will the edge become sharper, but you will also be removing any pitting and rust that has formed at the edge of your tool's blade.

In instances where the moving parts of your garden tools (such as with of any new pruners, shears, and loppers) have frozen in place, like springs and pivot joints. You should disassemble them first removing carefully any rust or dirt that may keep the tool from functioning properly. Clean accumulated rust and dirt off all metal surfaces with a wire brush. Remove stubborn rust from small tools with a fine steel wool. Using an old toothbrush with some lightweight lubricating oil is a great way to work fresh oil into the joints of most garden tools. Not only will this fresh oil help your tool to work as it was intended, but it will also prevent the formation of rust. Use medium-grit sandpaper to remove rust on larger tools such as shovels, spades, and hoes.



Once your tools are cleaned, they're ready to be sharpened. When sharpening, try to maintain the original factory bevel or angle. For pruners, use a whetstone because it produces a very sharp cutting edge. Depending on the type of whetstone, apply a few drops of oil or water to the stone. With the beveled side of the blade against the stone, rub the sharp edge of the blade toward the stone in a curved motion, as if you were trying to shave off a thin slice from the stone.



When working with a file, stabilize the blades in a vise, or against a solid surface such as a work bench, to avoid injury and ensure an even stroke. Always push the file across the blade in a motion away from your body. Move the file diagonally, so that its cutting teeth are biting into the metal on the tool. When sharpening with a file, do not use oil; metal filings will accumulate and clog the file's serrations.

Farm implements like ordinary plow and wooden harrow should be checked thoroughly before use. Loosened bolts and nuts should be tightened firmly. Disc plow, and harrow, should also be lubricated on their moving parts like bearings. Tractors should be tuned-up by skilled operator. Checking on their oil, a lubricant, fuel and cooling system.



Tools that are worn out should be separated and be fixed immediately to avoid accidents.

Upkeep of Equipment

- Keep a detailed service record. Scheduled service intervals are usually found in the owner's manual, but many tractors do not get enough use to reach the hour requirements for oil changes, etc., so these services may be done on an annual basis instead.
- When lubricating grease fittings, it is best practice to lubricate in both the loaded and unloaded positions, as the grease will only press into the unloaded space in either position. Greasing in both positions will better provide a complete lubrication.
- The battery in this tractor has little protection so it should be checked often
- Always allow tractors, especially diesel engine tractors, to warm up when cranked after a long period of non-use. Never over rev the engine when it is first started. Hydraulic lifters, hydraulic pumps, and oil pumps may drain down while the tractor is not in use, and damage can occur to these components.
- Check lug nuts. The lug nuts on the large back wheels are prone to work loose if not torque properly.
- The rear wheel has a tapered hub, so reversing the wheel brings the tire in toward the tractor's center
- Learn to reverse the wheels if you use the tractor for field operations that require different wheel width settings. Some equipment, such as bottom plows or mowers, work better with a narrow wheel width, where for planting and cultivating crops you may need the wheels set out to the widest width.



How Much Have You Learned?

Self-Check 3.1

TRUE OR FALSE: Read and analyze each statement below. Write True if the statement is correct; False if the statement is incorrect on the space provided for.

1. The best way to use the stone is to find a way to stabilize the tool that you want to work on.
2. Tools that are worn out should be separated and fixed immediately to avoid accident.
3. When sharpening, try to maintain the original factory bevel or angle.
4. Always push the file across the blade in a motion away from your body
5. Clean accumulated rust and dirt off all metal surfaces with a wire brush
6. Move the file diagonally, so that its cutting teeth are biting into the metal on the tool.
7. Use medium-grit sandpaper to remove rust on larger tools such as shovels, spades, and hoes.
8. When sharpening with a file, do not use oil; metal filings will accumulate and clog the file's serrations.
9. Oil helps tool to work as intended, and will prevent the formation of rust.
10. For pruners, use a whetstone because it produces a very sharp cutting edge.

Refer to the Answer Key. What is your score?



How Do You Apply What You Learned?

Show that you learned something by doing this activity

Activity Sheet 3.1

CREATING FORMS FOR MONITORING THE PREVENTIVE MAINTENANCE

Materials needed:

- Ballpen
- Bond paper
- Farm tools and equipment

Instructions

After learning about the preventive maintenance of different farm equipment, you will making an inventory reflecting the conditions of all the tools and equipment.

1. Make a list of all the tools and equipment
2. Create a maintenance checklist of all the tools and equipment reflecting its regular and periodic cleaning
3. Create an inspection checklist reflecting its condition
4. Create an inspection summary checklist stating the conditions and the action to be done
5. Compile the sheets in one folder and submit to your teacher.

Operation Sheet 3.1

Sharpening of Tools

Materials, Tools and Equipment:

Materials:		
○ Oil	-	
○ Rag	-	1 pc
○ Sand Paper 300	-	1 pc
Tools		
○ Hedge shear	-	1 set
○ Metal clamp	-	1 set
○ File	-	1 pc
○ Wrench		
○		

Introduction:

Hoes, forks, shears, and spades become blunt and eventually will need sharpening steel. Use a file or sharpening steel. Sharpen the upper surface. Then rub it over with an oily rag.

Procedure:

Step 1: Tighten the pivot nut. Before sharpening, check the pivot nut. It could be loose, making the blades drift apart while cutting and tear the twig instead of cutting it cleanly. The nut should be snug with no play in the pivot. With the nut tightened, check the tool. If it cuts cleanly, it doesn't need sharpening. If it still cuts poorly, look down each blade to make sure it's not bent. If a blade is slightly bent, loosen the pivot nut and separate the blades. To straighten the blade, put it in a vise, slip on some thick leather gloves and tweak it until it is straight.



Step 2: File the edge to expose clean metal. Clamp the blade firmly in a vise. Examine the factory edge. Hold the file with both hands and mimic the direction of the bevel like a golfer taking a practice putt. Now move the file in one broad stroke away from you along the entire cutting angle. To move the file in one direction, away from you. Don't use small, jerky strokes or you'll lose the factory edge. As you work, you can see the clean metal path left by the file. Adjust your angle as needed to file the entire edge evenly. Repeat this motion several times until you expose clean metal over the whole edge. Usually it will take only about 10 strokes. Do the same with other blade.



Step 3: Sand the back side of the blade. Place a sheet of 300-grit wet/dry sandpaper on a smooth, flat piece of plywood. You'll be able to feel the burrs (be careful—they're sharp) on the back side of each blade caused by the filing action. To remove them, lightly sand the back side of the blade. Keep the blade flat and move it in a circular motion. After making several circles, pick up the blade and gently feel the edge. When the burrs left by the file disappear, assemble the blades and lightly oil the moving parts with 3-In-One oil.



Step 4. Perform house keeping



How Well Did You Perform?

Find out by accomplishing the Scoring Rubric honestly and sincerely.
Remember it is your learning at stake!

For Activity 3.1

Criteria	Score			
	20	15	10	5
Completeness				
Well organized				
Neatness				
Updated				

For Operation 3.1

Criteria	Score			
	20	15	10	5
The blade is properly sharpened				
The nut is properly removed and returned				
The step by-step procedures are correctly followed				
The safety precautions are properly observed.				
Housekeeping is performed accordingly				

Interpretation of Scores:

16 – 20 – Excellent output

11 – 15 – Very good

6 – 10 – Fair output

5 and below – Poor output

**Congratulations! You did a great job!
Rest and relax a while then move on to
the next lesson. Good luck!**



REFERENCES

LO1

- Agricultural Arts for Secondary
- Agricultural Arts (T.H.E., SEDP, NSEC series) by Ramon G. Asuncion et.al.
- Farm Mechanics Textbook by Phipps, McColly, Scranton, & Cook
- Growing Vegetables by Tony Biggs
- Growing Rich, Tasty Veggies in Harmony with Nature, vol. 1 by Jef Van Haute-Lyds Quileste Van Haute
- <http://www.antiquefarmtools.info>
- <http://www.cdc.gov/niosh/pdfs/01-111b>
- <http://www.ebc.com.au>

LO 2

- <http://library.thinkquest.org/TQ0312380/machine.htm>
- <http://www.agmachine.com/xmmd43d.htm>

LO 3

- <http://library.thinkquest.org/TQ0312380/machine.htm>
- <http://www.agmachine.com/xmmd43d.htm>

LESSON 2

PERFORM ESTIMATION AND BASIC CALCULATION



LEARNING OUTCOMES:

At the end of this Lesson, you are expected to do the following:

- LO 1. perform estimation; and
- LO 2. perform basic workplace calculations.



Definition of Terms

Area - refers to the size of the surface

Fertilizer - any material added to the soil to support nutrient

Germination- the development of the seed into a young plant

Graph- a drawing in which the relationship between two (or more) items of information (e.g. Time and plant growth) is shown in a symbolic way.

Gross Income/Sales - the equivalent value of the product sold.

Interest- is the corresponding value that will be added to the principal as payment for using money of the lender.

Labor- refers to the work performed by farm workers in exchange for salary.

Net Income- is the value remains after all the expenses have been deducted from the gross income or sales.

Principal –refers to the amount you owed.

Volume- is the content of a body or object

Acronyms

MAD(Man Animal Day) refers to the number of day/s the work will be completed by 1 person and 1 animal.

MD-(Manday) refers to the number of day/s the work will be completed by 1 person.

LEARNING OUTCOME 1

Perform Estimation

PERFORMANCE STANDARDS

- Job requirements are identified from written or oral communications.
- Quantities of materials and resources required to complete a work task are estimated.
- Time needed to complete a work activity is estimated.
- Accurate estimate for work completion are made.
- Estimate of materials and resources are reported to appropriate person.
- Determine the cost and return of producing horticultural crops.
- Determine the profit/loss using the four fundamental operations.
- Determine the price of a product with the use of mark up percentage.



Materials

- Calculator
- Pencil
- Graphing paper
- References



What Do You Already Know?

Let us determine how much you already know about estimation for farm activities. Take this test.

Pretest LO 1

Label the following pictures



1. _____



2. _____



3. _____



3. _____



4. _____



6. _____



7. _____



8. _____



9. _____



10. _____



What Do You Need To Know?

Read the Information Sheet 1.1 Find out how much you can remember, and how much you learned by doing Self-check 1.1.

Information Sheet 1.1

FARM INPUTS



SEEDS



SEEDLINGS



FERTILIZER



INSECTICIDES

FARM LABOR

LABOR REQUIREMENT FOR LAND PREPARATION

Plowing using a tractor



Clearing the land using hoe



Plowing using animal



Harrowing using hand tractor



Preparation of Furrow



Trellis Preparation (for cucurbit crops)



Mulching

Digging Holes (for orchard)



Students of Balagtas National Agricultural High School



LABOR REQUIREMENT IN PLANTING

PRODUCTION OF SEEDLINGS



TRANSPLANTING



LABOR REQUIREMENT FOR PLANT CARE

FERTILIZER APPLICATION



PEST CONTROL



IRRIGATION



WEEDING



HARVESTING



Estimating Farm Inputs and Labor Requirements

Estimated irrigation expenses from planting up to last harvest *

Irrigation expenses is the product of price of water per volume, the number of volumes per day and total number of days to be irrigated from planting to last harvest. This is expressed as

$$\text{Irrigation Expenses} = \frac{\text{Price of Water}}{\text{Volume}} \times \frac{\text{No. of volumes}}{\text{Day}} \times \text{Total no. of days}$$

Estimated worker hired to perform irrigation from planting to last harvest.*

$$\text{Estimated workers} = \frac{\text{Worker}}{\text{Square area}} \times \text{Total irrigated area}$$

Estimated number of days for spraying insecticides* (per worker)

$$\text{Estimated no. of days} = \frac{\text{No. of days}}{\text{Square area}} \times \text{Total land area}$$

Estimated workers needed for spraying insecticides* (in one day)

$$\text{Estimated workers} = \frac{\text{No. of worker}}{\text{Square area}} \times \text{Total land area}$$

Estimated cost of insecticide use for spraying*

$$\text{Estimated cost} = \frac{\text{Price}}{\text{Insecticides}} \times \frac{\text{No. of insecticides}}{\text{Square area}} \times \text{Total land area}$$

Workers' salary during insecticide spraying*

$$\text{Worker' salary} = \frac{\text{Salary}}{\text{Day}} \times \text{Total no. of days}$$

Estimated number of weeding operation*

Estimated number of workers needed in weeding*

$$\text{Estimated workers} = \frac{\text{No. of worker}}{\text{Square area}} \times \text{Total land area}$$

Workers salary during weeding

$$\text{Workers salary} = \frac{\text{Salary}}{\text{Worker}} \times \text{Total no. workers}$$

Estimated number of workers employ during harvesting

$$\text{Workers employed} = \frac{\text{No. of worker}}{\text{Square area}} \times \text{Total land harvesting area}$$

Example:

Given the gathered data

Total land area	50 ,000 sq meter
Amount of fertilizer	20/kilo
Number of days consumed in planting the area	2 day
Number of workers planted the area	5 workers
Amount of salary paid in planting the area	300/day
Number of workers who fertilized the area from planting up to the date of this survey.	2 workers
Quantity of fertilizer used from planting up to the date where survey was made	200 kilos
Amount of salary paid in applying fertilizer from planting to the date of this survey	300/day
Quantity of fertilizer to be used after the survey until final harvesting*	500 kilos
Number of workers required to perform fertilization after the survey until final harvesting*	2 workers
Amount of salary paid in applying fertilizer from planting to the date of this survey	300/day

Computation:**a) Total amount of salary paid in planting the area**

Total amount of salary = (no. of days)(no. of workers)(amount of salary)
Total amount of salary paid in planting the area = (2)(5)(300) = 3,000.00

b) Total amount of fertilizer consumed from planting up to the date of the survey

Total amount of fertilizer = (amount of fertilizer per kilo)(no. of kilos)
Total amount of fertilizer = (20)(200) = 4,000.00

c) Total amount of salary paid in fertilizing the area from planting up to the date of the survey

Total amount of salary = (no. of days)(no. of workers)(amount of salary)
Total amount of salary paid in fertilizing the area = (2)(2)(300) = 1,200.00

d) Total amount of fertilizer consumed after the survey until final harvesting

Total amount of fertilizer = (amount of fertilizer per kilo)(no. of kilos)
Total amount of fertilizer = (20)(400) = 8,000.00

e) Total amount of salary paid in fertilizing the area after the survey until final harvesting

Total amount of salary = (no. of days)(no. of workers)(amount of salary)
Total amount of salary paid in fertilizing the area = (4)(2)(300) = 2,400.00

Total cost of all the expenses is the sum of the following:

Total amount of salary paid in planting the area	3,000.00
Total amount of fertilizer consumed from planting up to the date of the survey	4,000.00
Total amount of salary paid in fertilizing the area from planting up to the date of the survey	1,200.00
Total amount of fertilizer consumed after the survey until final harvesting	8,000.00
Total amount of salary paid in fertilizing the area after the survey until final harvesting	2,400.00
Total cost of all the expenses	18,600.00



How Much Have You Learned?

Self-Check 1.1

Give three (3) examples of farm input

Enumerate seven (7) farm activities that require labor force

Refer to the Answer Key. What is your score?

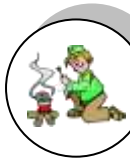

How Do You Apply What You Have Learned?

Show that you have learned something by doing this activity.

Activity Sheet 1.1

Estimating Farm Inputs and Labor Requirements

SPECIFIC INSTRUCTIONS:

1. Visit vegetable farm near your school or home
2. Get the following data
 - a. Area
 - b. Crop
 - c. Age of crop
 - d. Planting distance between furrows and between hills
 - e. Number of plants
 - f. Number of workers who prepared the land
 - g. Number of days consumed in preparing the area
 - h. Amount of salary given to each worker during land preparation
 - i. Number of workers planted the area
 - j. Number of days consumed in planting the area
 - k. Amount of salary paid in planting the area
 - l. Number of workers who fertilized the area from planting up to the date of this survey.
 - m. Quantity of fertilizer used from planting up to the date where survey was made
 - n. Amount of salary paid in applying fertilizer from planting to the date of this survey
 - o. Quantity of fertilizer to be used after the survey until final harvesting

- p. Number of workers required to perform fertilization after the survey until final harvesting
- q. Amount of salary needed for fertilizer application after this survey until final harvesting
- r. Estimated irrigation expenses from planting up to last harvest *
- s. Estimated worker hired to perform irrigation from planting to last harvest.*
- t. Estimated number of days for spraying insecticides*
- u. Estimated workers needed for spraying insecticides*
- v. Estimated cost of insecticide use for spraying*
- w. Workers' salary during insecticide spraying*
- x. Estimated number of weeding operation*
- y. Estimated number of workers needed in weeding*
- z. Workers salary during weeding
- aa. Estimated harvesting period
- bb. Estimated number of workers employ during harvesting

3. Present your data in a tabular form



How Well Did You Perform?

**Find out by accomplishing the Scoring Rubric honestly and sincerely.
Remember it is your learning at stake!**

Criteria	Score			
	20	15	10	5
Required measuring tool is used in measuring the area.				
The data gathered is consistent				
The respondent answers the question carefully				
The safety precautions are properly observed.				
Data are presented in a tabular form				

Interpretation of Scores:

16 – 20 – Excellent output

11 – 15 – Very good

6 – 10 – Fair output

5 and below – Poor output

***from transplanting to last harvest**

LEARNING OUTCOME 2

Perform basic workplace calculations

PERFORMANCE STANDARDS

- Calculations to be made shown should be identified according to job requirements.
- Correct method of calculation should be determined.
- Systems and units of measurement to be followed should be ascertained.
- Calculations needed to complete work task should be performed using the four basic mathematical operations.
- Appropriate operations should be used to comply with the instructions.
- Result obtained should be reviewed and thoroughly checked



Materials

- Mathematics Books
- Ruler
- Calculators
- Relevant tools and equipment for basic calculations



What Do You Already Know?

Let us determine how much you already know about basic workplace calculations. Take this test.

Pretest LO 2

ANSWER THE FOLLOWING:

A. Convert the following:

1. $1\text{m} = \underline{\hspace{1cm}}\text{cm}$
2. $400\text{cm} = \underline{\hspace{1cm}}\text{m}$
3. $5\text{km} = \underline{\hspace{1cm}}\text{m}$
4. $1\text{km} = \underline{\hspace{1cm}}\text{cm}$
5. $2000\text{ m} = \underline{\hspace{1cm}}\text{km}$

B. Find the area (hectare) of the following:

1. $600\text{m} \times 600\text{m}$
2. $100\text{m} \times 1000\text{m}$
3. $200\text{m} \times 300\text{m}$
4. $300\text{m} \times 400\text{m}$
5. $500\text{m} \times 600\text{m}$

Compute the following:

1. 6% of 100 plants were replaced
2. 15% of 28 hectares are harvested
3. 80% of 90 farmers are present
4. 50% of P200 increase in farmers salary
5. 5% of 100 kg seeds are dormant



What Do You Need To Know?

Read the Information Sheet 2.1 very well. Then find out how much you can remember and how much you learned by doing Self-check 2.1.

Information Sheet 2.1

PERFORM CALCULATION

It is important to be able to measure and calculate surface areas. It might be necessary to calculate, for example, the surface area of the cross-section of a canal or the surface area of a farm.

This Section will discuss the calculation of some of the most common surface areas: the triangle, the square, the rectangle, the rhombus, the parallelogram, the trapezium, and the circle.

The most common surface areas



TRIANGLE



RECTANGLE



SQUARE

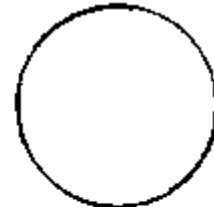

CIRCLE



RHOMBUS



PARALLELOGRAM



TRAPEZIUM

The height (h) of a triangle, a rhombus, a parallelogram or a trapezium, is the distance from a top corner to the opposite side called base (b). The height is always perpendicular to the base; in other words, the height makes a *right angle* with the base. An example of a right angle is the corner of this page.

In the case of a square or a rectangle, the expression length (l) is commonly used instead of base and width (w) instead of height. In the case of a circle the expression diameter (d) is used.

The height (h), base (b), width (w), length (l) and diameter (d) of the most common surface areas

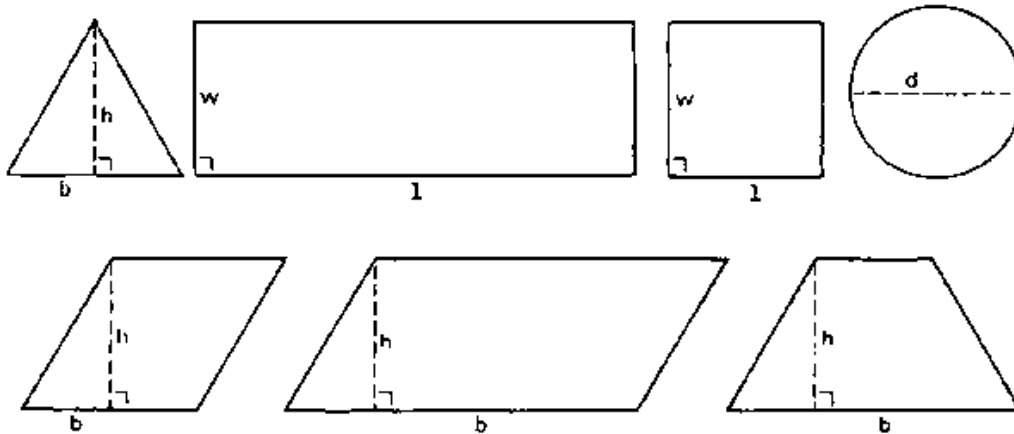

TRIANGLES

The surface area or surface (A) of a triangle is calculated by the formula:

$$A (\text{triangle}) = 0.5 \times \text{base} \times \text{height} = 0.5 \times b \times h \dots (1)$$

Triangles can have many shapes but the same formula is used for all of them.

Some examples of triangles

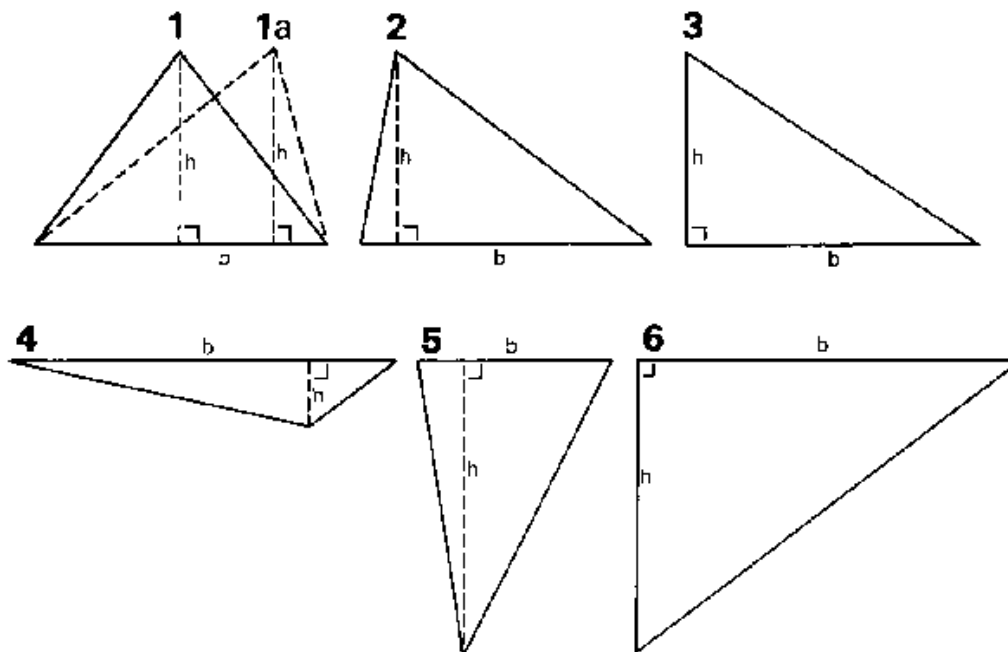

EXAMPLE

Calculate the surface area of the triangles no. 1, no. 1a and no. 2

Given

Triangles no. 1 and no. 1a:

base = 3 cm
height = 2 cm

Triangle no. 2:

base = 3 cm
height = 2 cm

Answer

Formula: $A = 0.5 \times \text{base} \times \text{height}$
 $= 0.5 \times 3 \text{ cm} \times 2 \text{ cm} = 3 \text{ cm}^2$

$A = 0.5 \times 3 \text{ cm} \times 2 \text{ cm} = 3 \text{ cm}^2$

It can be seen that triangles no. 1, no. 1a and no. 2 have the same surface; the shapes of the triangles are different, but the base and the height are in all three cases the same, so the surface is the same.

The surface of these triangles is expressed in square centimeters (written as cm^2). Surface areas can also be expressed in square decimeters (dm^2), square meters (m^2), etc...

QUESTION

Calculate the surface areas of the triangles nos. 3, 4, 5 and 6.

Given

Triangle no. 3:

base = 3 cm
height = 2 cm

Triangle no. 4:

base = 4 cm
height = 1 cm

Triangle no. 5:

base = 2 cm
height = 3 cm

Triangle no. 6:

base = 4 cm
height = 3 cm

Answer

Formula: $A = 0.5 \times \text{base} \times \text{height}$
 $= 0.5 \times 3 \text{ cm} \times 2 \text{ cm} = 3 \text{ cm}^2$

$A = 0.5 \times 4 \text{ cm} \times 1 \text{ cm} = 2 \text{ cm}^2$

$A = 0.5 \times 2 \text{ cm} \times 3 \text{ cm} = 3 \text{ cm}^2$

$A = 0.5 \times 4 \text{ cm} \times 3 \text{ cm} = 6 \text{ cm}^2$

SQUARES AND RECTANGLES

The surface area or surface (A) of a square or a rectangle is calculated by the formula:

$$A (\text{square or rectangle}) = \text{length} \times \text{width} = l \times w \dots (2)$$

In a square, the lengths of all four sides are equal, and all four angles are right angles.

In a rectangle, the lengths of the opposite sides are equal, and all four angles are right angles.

A square and a rectangle

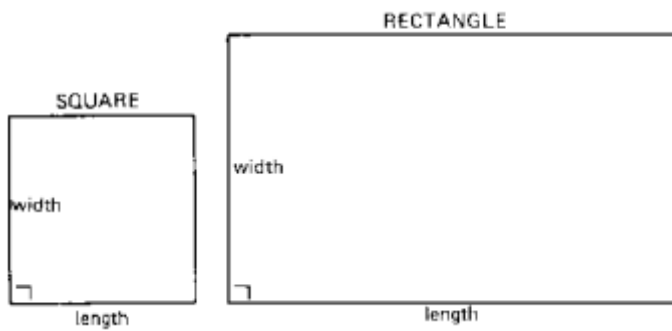

Note that in a square the length and width are equal and that in a rectangle the length and width are not equal.

QUESTION

Calculate the surface areas of the rectangle and of the square.

Given

Square: length = 2 cm
width = 2 cm

Rectangle: length = 5 cm
width = 3 cm

Answer

Formula: $A = \text{length} \times \text{width}$
 $= 2 \text{ cm} \times 2 \text{ cm} = 4 \text{ cm}^2$

Formula: $A = \text{length} \times \text{width}$
 $= 5 \text{ cm} \times 3 \text{ cm} = 15 \text{ cm}^2$

In relation to irrigation, you will often come across the expression hectare (ha), which is a surface area unit. By definition, 1 hectare equals $10\,000 \text{ m}^2$. For example, a field with a length of 100 m and a width of 100 m has a surface area of $100 \text{ m} \times 100 \text{ m} = 10\,000 \text{ m}^2 = 1 \text{ ha}$.

Fig. 4. One hectare equals $10\,000 \text{ m}^2$

$$\text{surface} = 100 \text{ m} \times 100 \text{ m} = 10\,000 \text{ m}^2 = 1 \text{ ha}$$

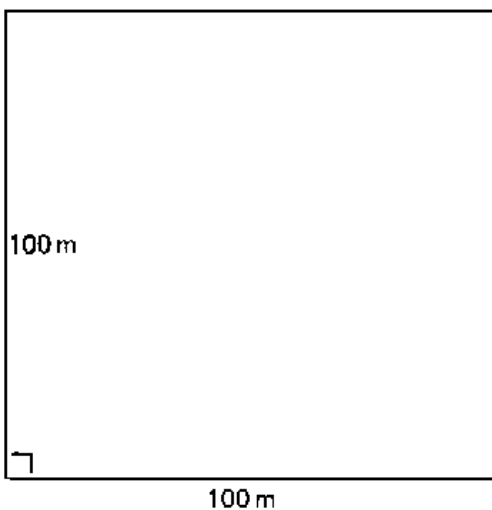

RHOMBUSES AND PARALLELOGRAMS

The surface area or surface (A) of a rhombus or a parallelogram is calculated by the formula:

$$A \text{ (rhombus or parallelogram)} = \text{base} \times \text{height} = b \times h \dots (3)$$

In a rhombus, the lengths of all four sides are equal; none of the angles are right angles; opposite sides run parallel.

In a parallelogram the lengths of the opposite sides are equal; none of the angles are right angles; opposite sides run parallel.

A rhombus and a parallelogram

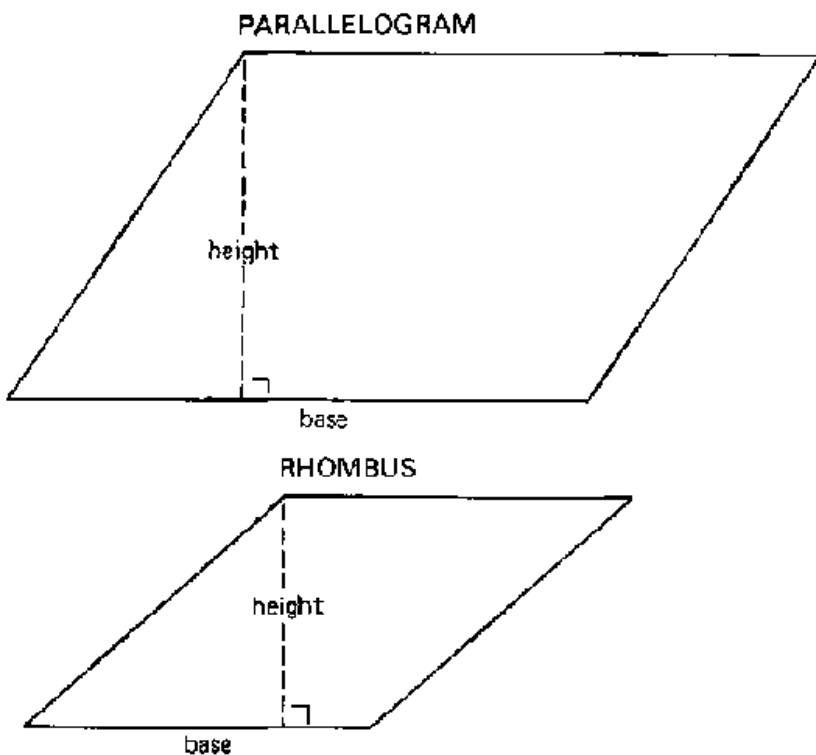

QUESTION

Calculate the surface areas of the rhombus and the parallelogram.

Given

Rhombus: base = 3 cm
height = 2 cm

Parallelogram: base = 3.5 cm
height = 3 cm

Answer

Formula: $A = \text{base} \times \text{height}$
 $= 3 \text{ cm} \times 2 \text{ cm} = 6 \text{ cm}^2$

Formula: $A = \text{base} \times \text{height}$
 $= 3.5 \text{ cm} \times 3 \text{ cm} = 10.5 \text{ cm}^2$

1.1.4 TRAPEZIUMS

The surface area or surface (A) of a trapezium is calculated by the formula:

$$A (\text{trapezium}) = 0.5 (\text{base} + \text{top}) \times \text{height} = 0.5 (b + a) \times h \dots (4)$$

The top (a) is the side opposite and parallel to the base (b). In a trapezium, only the base and the top run parallel.

Some examples are shown below:

Some examples of trapeziums

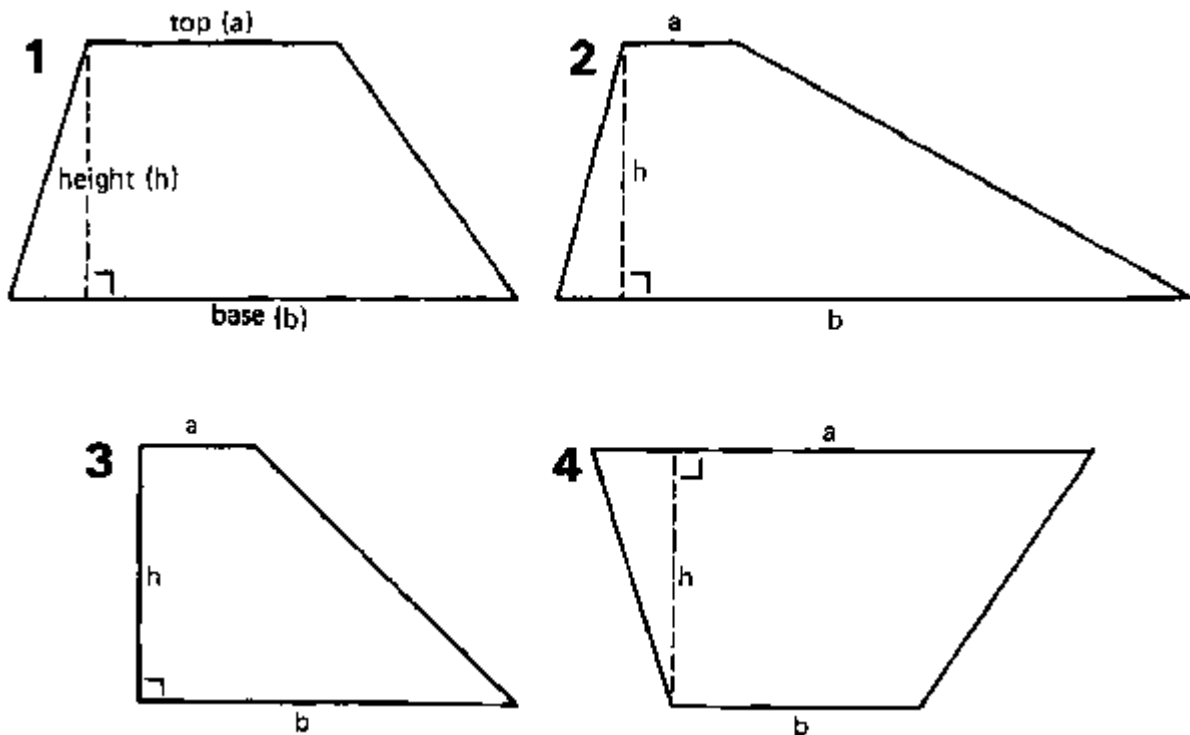

EXAMPLE

Calculate the surface area of trapezium no. 1.

Given

Trapezium no. 1: base = 4 cm
top = 2 cm
height = 2 cm

Answer

Formula: $A = 0.5 \times (\text{base} + \text{top}) \times \text{height}$
 $= 0.5 \times (4 \text{ cm} + 2 \text{ cm}) \times 2 \text{ cm}$
 $= 0.5 \times 6 \text{ cm} \times 2 \text{ cm} = 6 \text{ cm}^2$

QUESTION

Calculate the surface areas trapeziums nos. 2, 3 and 4.

Given

Answer

Trapezium no. 2:

base = 5 cm
top = 1 cm
height = 2 cm

Formula: $A = 0.5 \times (\text{base} + \text{top}) \times \text{height}$
 $= 0.5 \times (5 \text{ cm} + 1 \text{ cm}) \times 2 \text{ cm}$
 $= 0.5 \times 6 \text{ cm} \times 2 \text{ cm} = 6 \text{ cm}^2$

Trapezium no. 3:

base = 3 cm
top = 1 cm
height = 1 cm

$A = 0.5 \times (3 \text{ cm} + 1 \text{ cm}) \times 2 \text{ cm}$
 $= 0.5 \times 4 \text{ cm} \times 2 \text{ cm} = 4 \text{ cm}^2$

Trapezium no. 4:

base = 2 cm
top = 4 cm
height = 2 cm

$A = 0.5 \times (2 \text{ cm} + 4 \text{ cm}) \times 2 \text{ cm}$
 $= 0.5 \times 6 \text{ cm} \times 2 \text{ cm} = 6 \text{ cm}^2$

Note that the surface areas of the trapeziums 1 and 4 are equal. Number 4 is the same as number 1, but upside down.

Another method to calculate the surface area of a trapezium is to divide the trapezium into a rectangle and two triangles, to measure their sides, and to determine separately the surface areas of the rectangle and the two triangles.

Split the trapezium into one rectangle and two triangles. Note that $A = A_1 + A_2 + A_3 = 1 + 6 + 2 = 9 \text{ cm}^2$

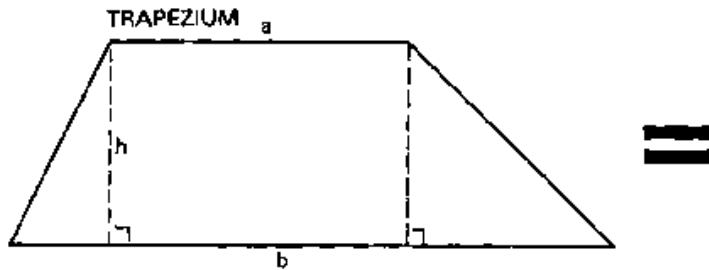

$a = 3 \text{ cm}$
 $b = 6 \text{ cm}$
 $h = 2 \text{ cm}$
 $A = 0.5(b + a) \times h = 9 \text{ cm}^2$

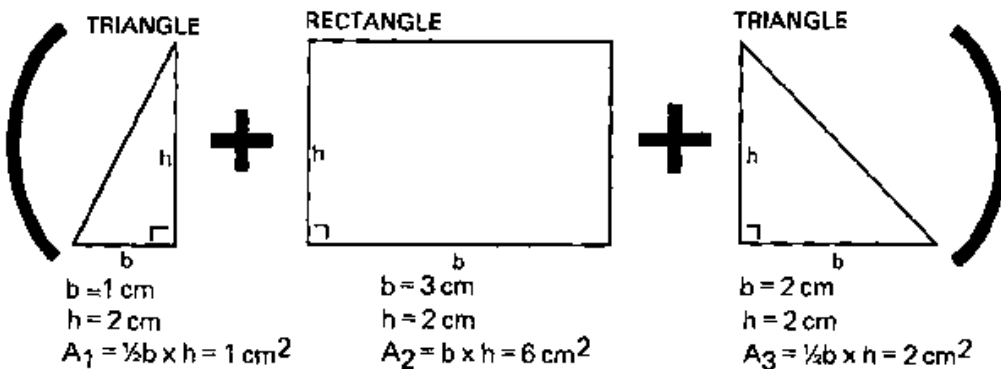

1.1.5 CIRCLES

The surface area or surface (A) of a circle is calculated by the formula:

$$A (\text{circle}) = \frac{1}{4} (\pi \times d \times d) = \frac{1}{4} (\pi \times d^2) = \frac{1}{4} (3.14 \times d^2) \dots (5)$$

whereby d is the diameter of the circle and π (a Greek letter, pronounced Pi) a constant ($\pi = 3.14$). A diameter (d) is a straight line which divides the circle in two equal parts.

A circle

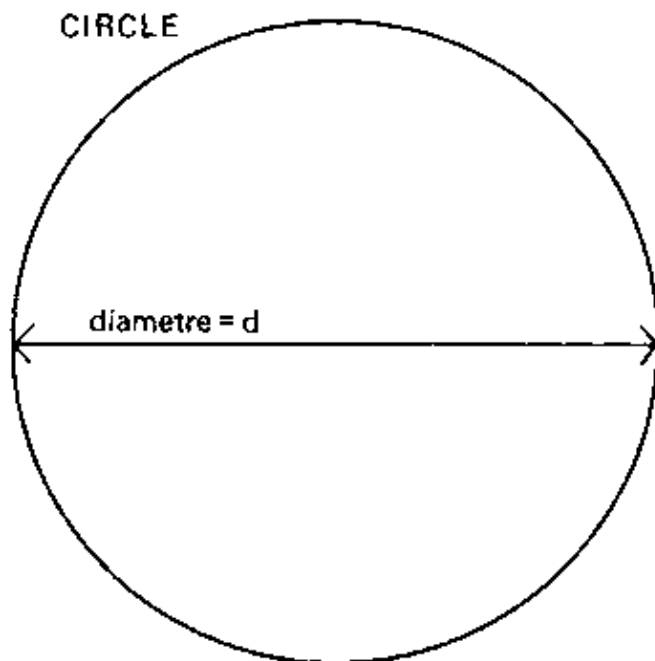

EXAMPLE

Given

Circle: d = 4.5 cm

Answer

$$\begin{aligned} \text{Formula: } A &= \frac{1}{4} (\pi \times d^2) \\ &= \frac{1}{4} (3.14 \times d \times d) \\ &= \frac{1}{4} (3.14 \times 4.5 \text{ cm} \times 4.5 \text{ cm}) \\ &= 15.9 \text{ cm}^2 \end{aligned}$$

QUESTION

Calculate the surface area of a circle with a diameter of 3 m.

Given

Circle: d = 3 m

Answer

$$\begin{aligned} \text{Formula: } A &= \frac{1}{4} (\pi \times d^2) = \frac{1}{4} (3.14 \times d \times d) \\ &= \frac{1}{4} (3.14 \times 3 \text{ m} \times 3 \text{ m}) = 7.07 \text{ m}^2 \end{aligned}$$

METRIC CONVERSIONS

Units of length

The basic unit of length in the metric system is the meter (m). One meter can be divided into 10 decimeters (dm), 100 centimeters (cm) or 1000 millimeters (mm); 100 m equals to 1 hectometer (hm); while 1000 m is 1 kilometer (km).

1 m = 10 dm = 100 cm = 1000 mm
0.1 m = 1 dm = 10 cm = 100 mm
0.01 m = 0.1 dm = 1 cm = 10 mm
0.001 m = 0.01 dm = 0.1 cm = 1 mm

1 km = 10 hm = 1000 m
0.1 km = 1 hm = 100 m
0.01 km = 0.1 hm = 10 m
0.001 km = 0.01 hm = 1 m

Units of surface

The basic unit of area in the metric system is the square meter (m²), which is obtained by multiplying a length of 1 meter by a width of 1 meter.

A square meter

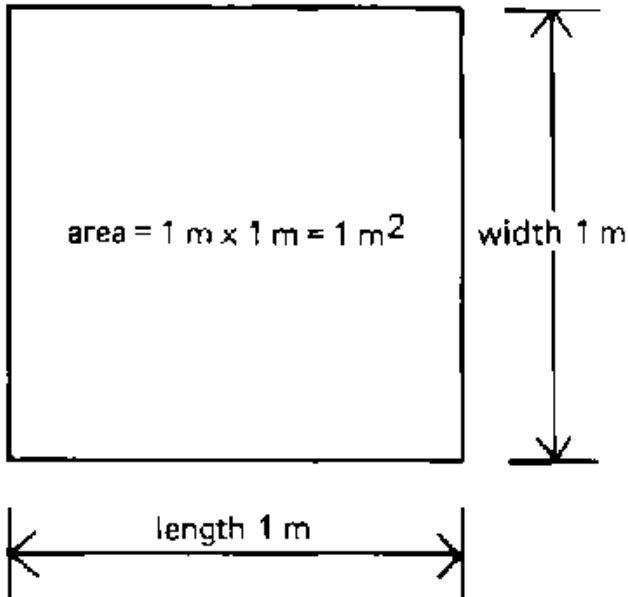

1 m² = 100 dm² = 10 000 cm² = 1 000 000 mm²
0.01 m² = 1 dm² = 100 cm² = 10 000 mm²
0.0001 m² = 0.01 dm² = 1 cm² = 100 mm²
0.000001 m² = 0.0001 dm² = 0.01 cm² = 1 mm²

$1 \text{ km}^2 = 100 \text{ ha}^2 = 1\,000\,000 \text{ m}^2$
 $0.01 \text{ km}^2 = 1 \text{ ha}^2 = 10\,000 \text{ m}^2$
 $0.000001 \text{ km}^2 = 0.0001 \text{ ha}^2 = 1 \text{ m}^2$

NOTE:

1 ha = 100 m x 100 m = 10 000 m²

SURFACE AREAS OF CANAL CROSS-SECTIONS AND FARMS

This section explains how one can apply the surface area formulas to two common practical problems that will often be met in the field.

DETERMINATION OF THE SURFACE AREAS OF CANAL CROSS-SECTIONS

The most common shape of a canal cross-section is a trapezium or, an "up-side-down" trapezium.

Canal cross-section

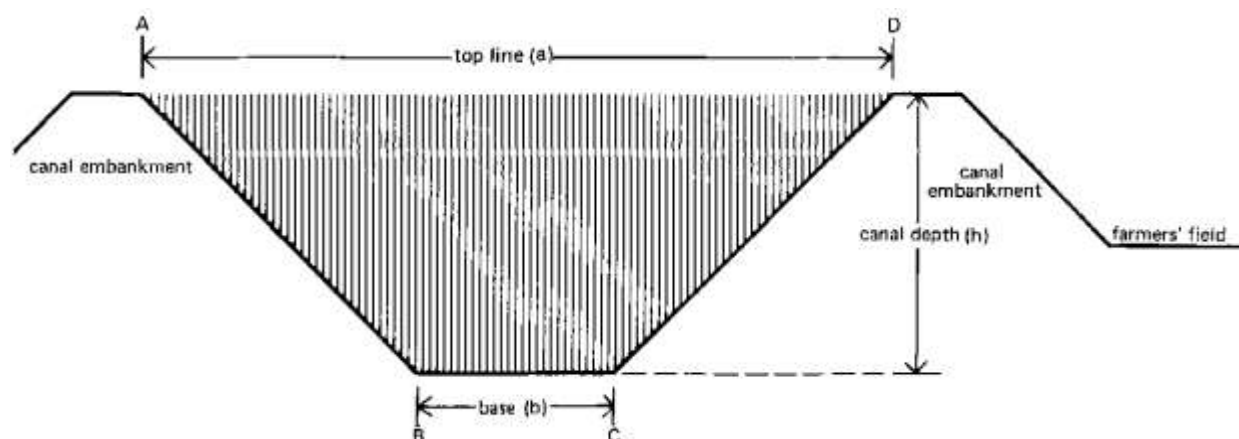

The area (A B C D), hatched on the above drawing, is called the canal cross-section and has a trapezium shape. Thus, the formula to calculate its surface is similar to the formula used to calculate the surface area of a trapezium:

Surface area of the canal cross-section = $0.5 (\text{base} + \text{top line}) \times \text{canal depth} = 0.5 (b + a) \times h \dots$
 (6)

whereby:

base (b) = bottom width of the canal

top line (a) = top width of the canal

canal depth (h) = height of the canal (from the bottom of the canal to the top of the embankment)

Suppose that the canal contains water, as shown in Figure below.

Wetted cross-section of a canal

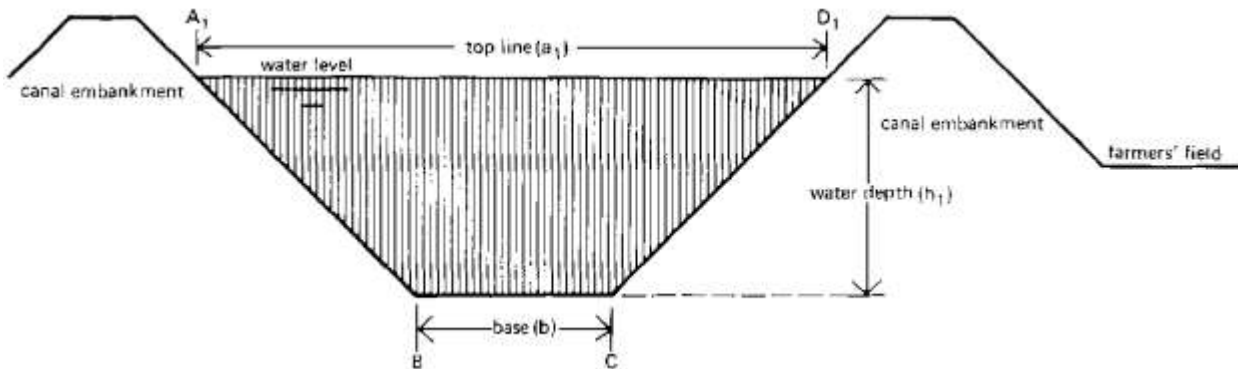

The area (A B C D), hatched on the above drawing, is called the wetted canal cross-section or wetted cross-section. It also has a trapezium shape. The formula to calculate its surface area is:

$$\text{Surface area of the wetted canal cross-section} = 0.5 (\text{base} + \text{top line}) \times \text{water depth} = 0.5 (b + a_1) \times h_1 \dots (7)$$

whereby:

base (b) = bottom width of the canal

top line (a₁) = top width of the water level

water depth (h₁) = the height or depth of the water in the canal (from the bottom of the canal to the water level).

EXAMPLE

Calculate the surface area of the cross-section and the wetted cross-section, of the canal shown in next figure.

Dimensions of the cross-section

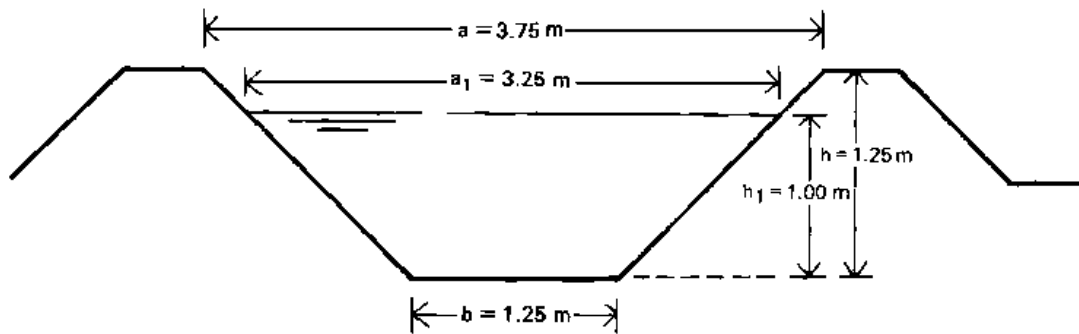

Given

Canal cross-section:

base (b) = 1.25 m

top line (a) = 3.75 m

canal depth (h) = 1.25 m

Canal wetted cross-section:

base (b) = 1.25 m

top line (a₁) = 3.25 m

water depth (h₁) = 1.00 m

Answer

Formula: $A = 0.5 \times (b + a) \times h$

$$= 0.5 \times (1.25 \text{ m} + 3.75 \text{ m}) \times 1.25 \text{ m} \\ = 3.125 \text{ m}^2$$

Formula: $A = 0.5 \times (b + a_1) \times h$

$$= 0.5 \times (1.25 \text{ m} + 3.25 \text{ m}) \times 1.00 \text{ m} \\ = 2.25 \text{ m}^2$$

DETERMINING THE SURFACE AREA OF A FARM

It may be necessary to determine the surface area of a farmer's field. For example, when calculating how much irrigation water should be given to a certain field, the size of the field must be known.

When the shape of the field is regular and has, for example, a rectangular shape, it should not be too difficult to calculate the surface area once the length of the field (that is, the base of its regular shape, and the width of the field have been measured.

Field of regular shape

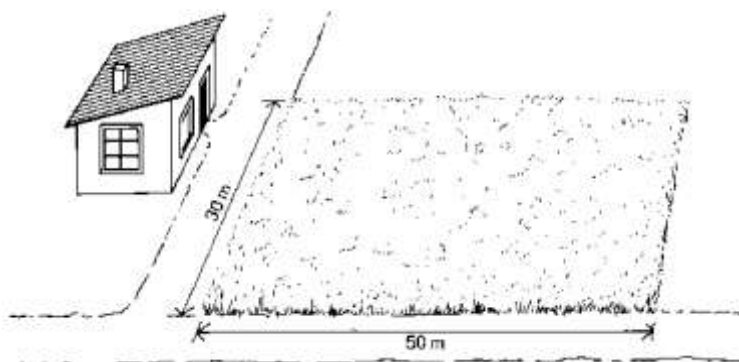

EXAMPLE

Given

Length of the field = 50 m

Width of the field = 30 m

Answer

Formula: $A = \text{length} \times \text{width}$ (formula 2)
 $= 50 \text{ m} \times 30 \text{ m} = 1500 \text{ m}^2$

QUESTION

What is the area of the same field, in hectares?

ANSWER

A hectare is equal to 10 000 m. Thus, the formula to calculate a surface area in hectares is:

$$\text{Surface area in hectares (ha)} = \frac{\text{surface area in square metres (m}^2\text{)}}{10\,000} \dots (8)$$

In this case: area of the field in $\text{ha} = \frac{1500 \text{ m}^2}{10\,000} = 0.15 \text{ ha}$

More often, however, the field shape is not regular, as shown in Figure below.

Field of irregular shape

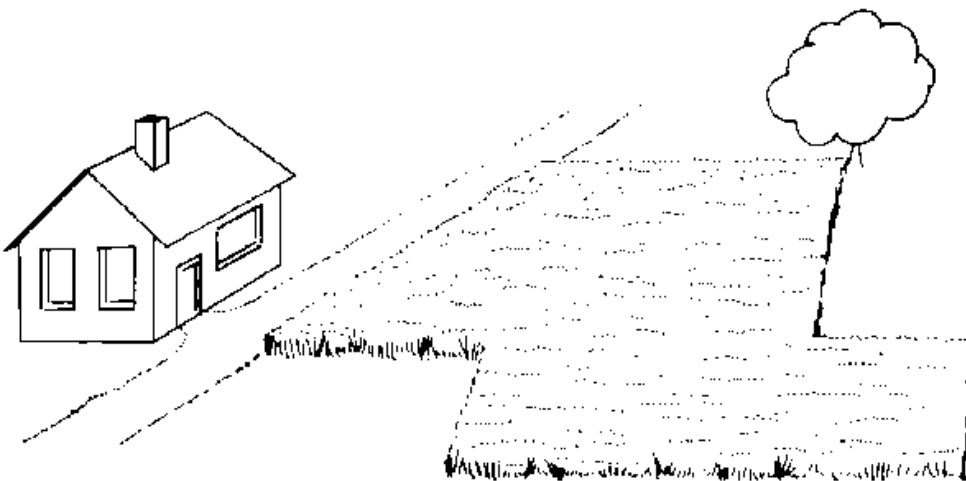

In this case, the field should be divided in several regular areas (square, rectangle, triangle, etc.).

Dividing an irregular field into regular areas

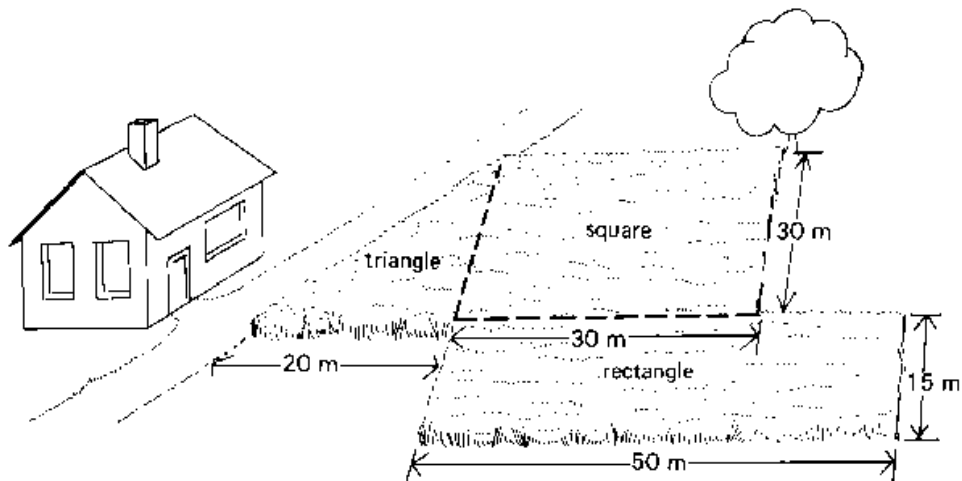

Surface area of the square: $A_s = \text{length} \times \text{width} = 30 \text{ m} \times 30 \text{ m} = 900 \text{ m}^2$

Surface area of the rectangle: $A_r = \text{length} \times \text{width} = 50 \text{ m} \times 15 \text{ m} = 750 \text{ m}^2$

Surface area of the triangle: $A_t = 0.5 \times \text{base} \times \text{height} = 0.5 \times 20 \text{ m} \times 30 \text{ m} = 300 \text{ m}^2$

Total surface area of the field: $A = A_s + A_r + A_t = 900 \text{ m}^2 + 750 \text{ m}^2 + 300 \text{ m}^2 = 1950 \text{ m}^2$

INTRODUCTION TO VOLUME

A volume (V) is the content of a body or object. Take a block for example. A block has a certain length (l), width (w) and height (h). Using this data, the volume of the block can be calculated using the formula:

$$V (\text{block}) = \text{length} \times \text{width} \times \text{height} = l \times w \times h \dots (9)$$

A block

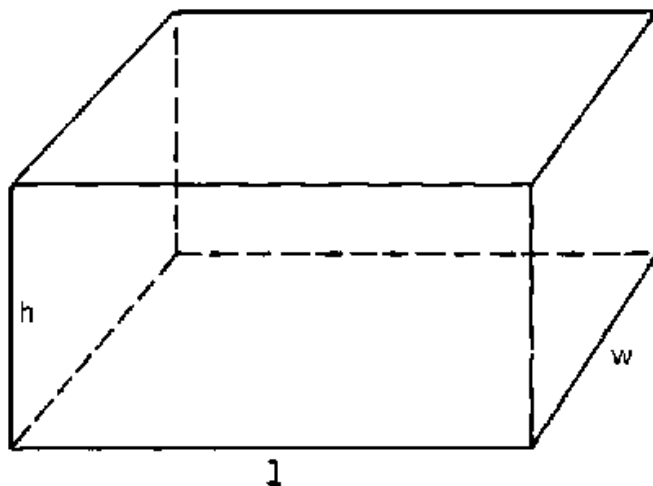

EXAMPLE

Calculate the volume of the block.

Given

length = 4 cm

width = 3 cm

height = 2 cm

Answer

Formula: $V = \text{length} \times \text{width} \times \text{height}$

$= 4 \text{ cm} \times 3 \text{ cm} \times 2 \text{ cm}$

$= 24 \text{ cm}^3$

The volume of this block is expressed in cubic centimeters (written as cm). Volumes can also be expressed in cubic decimeters (dm^3), cubic meters (m^3), etc.

QUESTION

Calculate the volume in m^3 of a block with a length of 4 m, a width of 50 cm and a height of 200 mm.

Given

All data must be converted in meters (m)

length = 4 m

width = 50 cm = 0.50 m

height = 200 mm = 0.20 m

Answer

Formula: $V = \text{length} \times \text{width} \times \text{height}$

$= 4 \text{ m} \times 0.50 \text{ m} \times 0.20 \text{ m}$

$= 0.40 \text{ m}^3$

QUESTION

Calculate the volume of the same block, this time in cubic centimeters (cm^3)

Given

All data must be converted in centimeters (cm)

length = 4 m = 400 cm

width = 50 cm

height = 200 mm = 20 cm

Answer

Formula: $V = \text{length} \times \text{width} \times \text{height}$

$= 400 \text{ cm} \times 50 \text{ cm} \times 20 \text{ cm}$

$= 400\,000 \text{ cm}^3$

Of course, the result is the same: $0.4 \text{ m}^3 = 400\,000 \text{ cm}^3$

UNITS OF VOLUME

The basic unit of volume in the metric system is the cubic meter (m^3) which is obtained by multiplying a length of 1 meter, by a width of 1 meter and a height of 1 meter.

One cubic meter

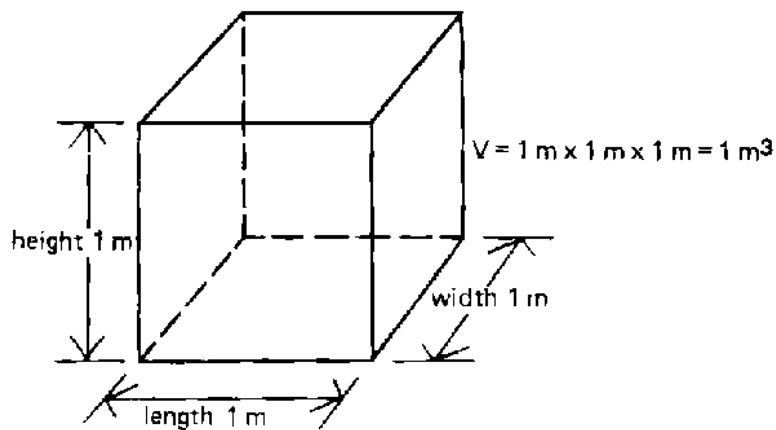

$$1\text{ m}^3 = 1.000\text{ dm}^3 = 1\,000\,000\text{ cm}^3 = 1\,000\,000\,000\text{ mm}^3$$

$$0.001\text{ m}^3 = 1\text{ dm}^3 = 1\,000\text{ cm}^3 = 1\,000\,000\text{ mm}^3$$

$$0.000001\text{ m}^3 = 0.001\text{ dm}^3 = 1\text{ cm}^3 = 1\,000\text{ mm}^3$$

$$0.000000001\text{ m}^3 = 0.000001\text{ dm}^3 = 0.001\text{ cm}^3 = 1\text{ mm}^3$$

NOTE

$$1\text{ dm}^3 = 1\text{ liter}$$

and

$$1\text{ m}^3 = 1000\text{ liters}$$

VOLUME OF WATER ON A FIELD

Suppose a one-liter bottle is filled with water. The volume of the water is thus 1 liter or 1 dm^3 . When the bottle of water is emptied on a table, the water will spread out over the table, and form a thin water layer. The amount of water on the table is the same as the amount of water that was in the bottle 1 liter.

The volume of water remains the same; only the shape of the "water body" changes.

One liter of water spread over a table

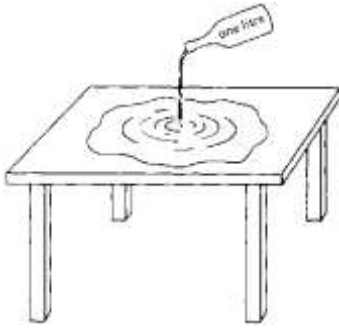

A similar process happens if you spread irrigation water from a storage reservoir over a farmer's field.

QUESTION

Suppose there is a reservoir, filled with water, with a length of 5 m, a width of 10 m and a depth of 2 m. All the water from the reservoir has been spread over a field of 1 hectare. Calculate the water depth (which is the thickness of the water layer) on the field.

A volume of 100 m³ of water spread over an area of one hectare

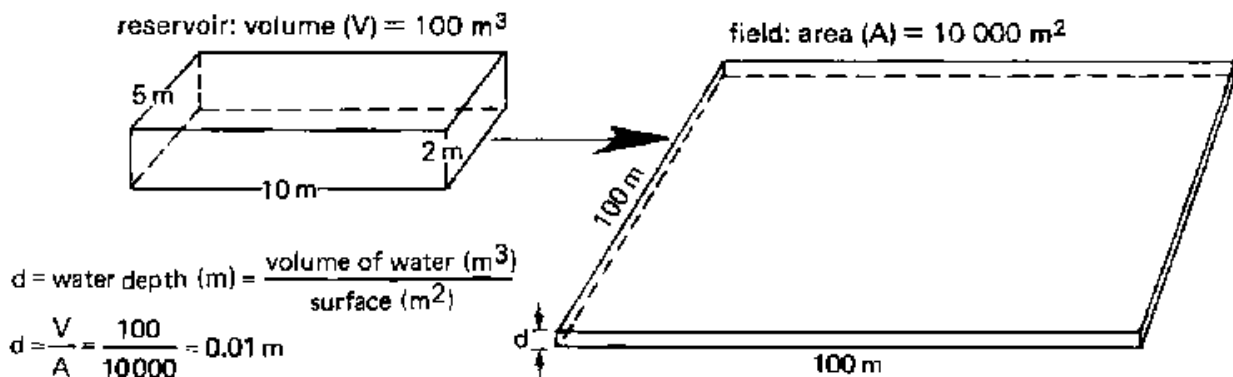

The formula to use is:

$$\text{Water depth (d)} = \frac{\text{Volume of water (V)}}{\text{Surface of the field (A)}} \dots (10)$$

Firstly, the volume of water must be calculated. It is the volume of the filled reservoir, calculated with formula (9):

$$\text{Volume (V)} = \text{length} \times \text{width} \times \text{height} = 5 \text{ m} \times 10 \text{ m} \times 2 \text{ m} = 100 \text{ m}^3$$

Secondly, the thickness of the water layer is calculated using formula (10):

Given

Surface of the field = 10 000 m²
 Volume of water = 100 m³

Answer

Formula: $d = \frac{\text{Volume of water (m}^3\text{)}}{\text{Surface of the field (m}^2\text{)}}$

$$d = \frac{100 \text{ (m}^3\text{)}}{10\,000 \text{ (m}^2\text{)}}$$

$$d = 0.01 \text{ m}$$

$$d = 10 \text{ mm}$$

QUESTION

A water layer 1 mm thick is spread over a field of 1 ha. Calculate the volume of the water (in m³).

One millimeter water depth on a field of one hectare

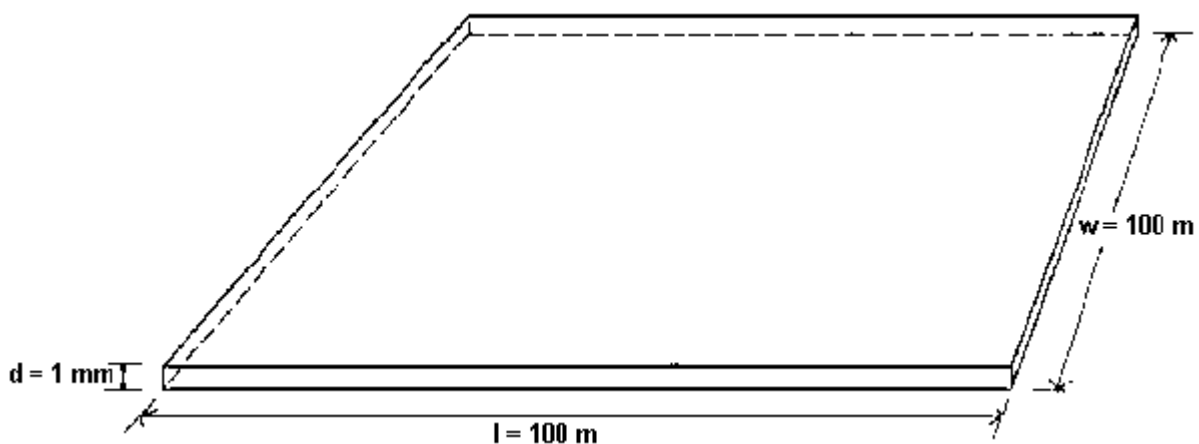

The formula to use is:

$$\text{Volume of water (V) = Surface of the field (A) x Water depth (d) (11)}$$

Given

Surface of the field = 10 000 m²
 Water depth = 1 mm = 1/1 000 = 0.001 m

Answer

Formula: = surface of the field (m²) x water depth (m)
 Volume (m³) V = 10 000 m² x 0.001 m
 V = 10 m³ or 10 000 litres

INTRODUCTION TO FLOW-RATE

DEFINITION

The flow-rate of a river, or of a canal, is the volume of water discharged through this river, canal, during a given period of time. Similar to irrigation, the volume of water is usually expressed in

liters (l) or cubic meters (m³) and the time in seconds (s) or hours (h). The flow-rate is also called discharge-rate.

CALCULATION AND UNITS

The water running out of a tap fills a one liter bottle in one second. Thus the flow rate (Q) is one liter per second (1 l/s).

A flow-rate of one liter per second

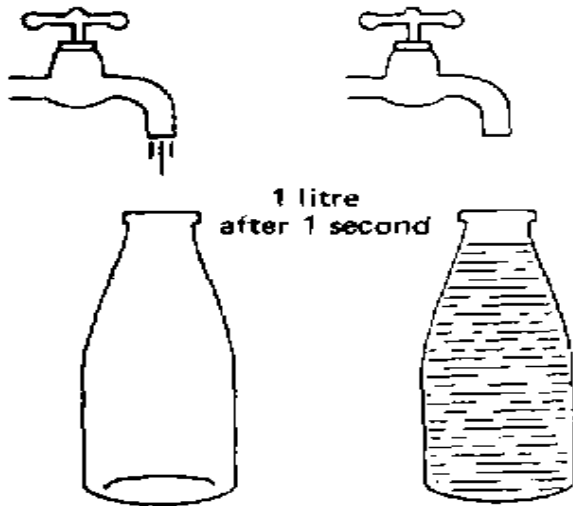

QUESTION

The water supplied by a pump fills a drum of 200 liters in 20 seconds. What is the flow rate of this pump?

The formula used is:

$$Q = \text{Flow - rate (l/s)} = \frac{\text{Volume of water (litres)}}{\text{Time (seconds)}} \dots (12a)$$

Given

Volume of water: 200 l

Time: 20 s

Answer

Formula:

$$Q = \frac{\text{Volume of water}}{\text{Time}} = \frac{200\text{l}}{20\text{s}} = 10\text{l/s}$$

The unit *liter per second* is commonly used for small flows, e.g. a tap or a small ditch. For larger flows, e.g. a river or a main canal, the unit *cubic metre per second* (m³/s) is more conveniently used.

QUESTION

A river discharges 100 m³ of water to the sea every 2 seconds. What is the flow-rate of this river expressed in m³/s?

The formula used is:

$$Q = \text{Flow - rate (m}^3/\text{s)} = \frac{\text{Volume of water (m}^3\text{)}}{\text{Time (seconds)}} \dots (12b)$$

Given

Volume of water: 100 m³

Time: 2 s

Answer

$$\text{Formula: } Q = \frac{\text{Volume of water}}{\text{Time}} = \frac{100\text{m}^3}{2\text{s}} = 50\text{m}^3/\text{s}$$

The discharge rate of a pump is often expressed in m³ per hour (m³/h), or in liters per minute (l/min).

$$Q = \text{Flow - rate (l/min)} = \frac{\text{Volume of water (litres)}}{\text{Time (minutes)}} \dots (12c)$$

$$Q = \text{Flow - rate (m}^3/\text{h)} = \frac{\text{Volume of water (m}^3\text{)}}{\text{Time (hours)}} \dots (12d)$$

NOTE: Formula 12a, 12b, 12c and 12d are the same; only the units change

INTRODUCTION TO PERCENTAGE

In relation to agriculture, the word *percentage* will be met regularly. For instance "60 percent of the total area is irrigated during the dry season". In this Section the meaning of the word "percentage" will be discussed.

PERCENTAGE

The word "percentage" means literally "per hundred"; in other words one percent is the one hundredth part of the total. You can either write percent, or %, or 1/100, or 0.01.

Some examples are:

$$5 \text{ percent} = 5\% = 5/100 = 0.05$$

$$20 \text{ percent} = 20\% = 20/100 = 0.20$$

$$25 \text{ percent} = 25\% = 25/100 = 0.25$$

$$50 \text{ percent} = 50\% = 50/100 = 0.50$$

$$100 \text{ percent} = 100\% = 100/100 = 1$$

$$150 \text{ percent} = 150\% = 150/100 = 1.5$$

QUESTION

How many oranges is 1% of a total of 300 oranges?

Three oranges are 1% of 300 oranges

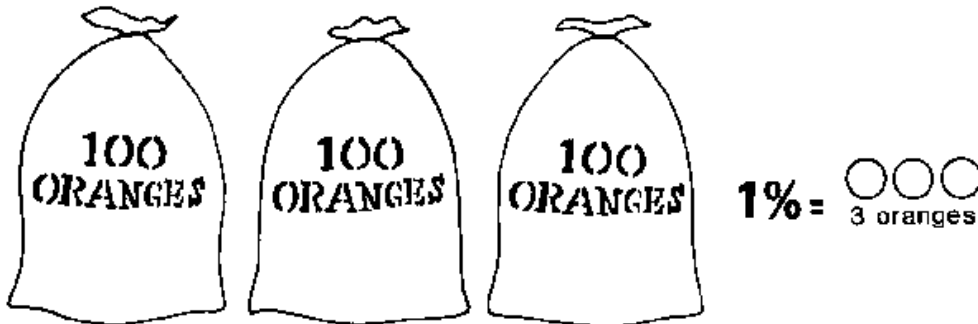

ANSWER

1% of 300 oranges = $\frac{1}{100} \times 300 = 3$ oranges

<u>QUESTIONS</u>	<u>ANSWERS</u>
6% of 100 cows	$\frac{6}{100} \times 100 = 6$ cows
15% of 28 hectares	$\frac{15}{100} \times 28 = 4.2$ ha
80% of 90 irrigation projects	$\frac{80}{100} \times 90 = 72$ projects
150% of a monthly salary of P100	$\frac{150}{100} \times 100 = 1.5 \times 100 = P150$
0.5% of 194.5 liters	$\frac{0.5}{100} \times 194.5 = 0.005 \times 194.5 = 0.9725$ liters

INTRODUCTION TO GRAPHS

A graph is a drawing in which the relationship between two (or more) items of information (e.g. time and plant growth) is shown in a symbolic way.

To this end, two lines are drawn at a right angle. The horizontal one is called the x axis and the vertical one is called the y axis.

Where the x axis and the y axis intersect is the "0" (zero) point.

The plotting of the information on the graph is discussed in the following example.

A graph

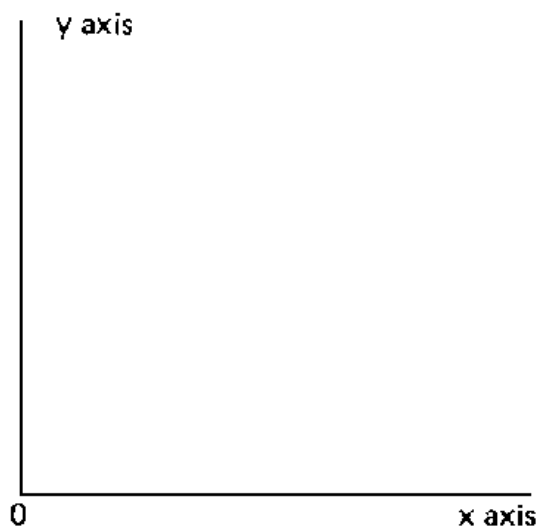

EXAMPLE 1

Suppose it is necessary to make a graph of the growth rate of a corn plant. Each week, the height of the plant is measured. One week after planting the seed, the plant measures 2 cm in height two weeks after planting, it measures 5 cm the height is 10 cm.

Measuring the growth rate of a corn plant

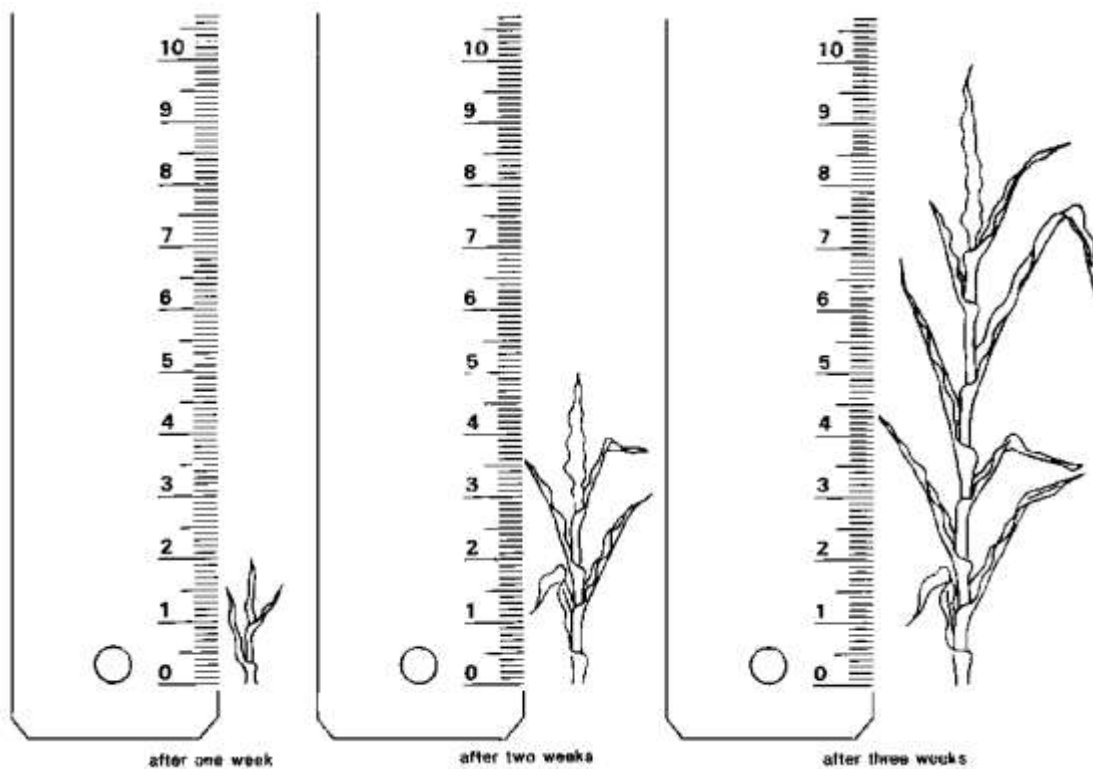

These results can be plotted on a graph. The time (in weeks) will be indicated on the x axis; 2 cm on the axis represents 1 week. The plant height (in centimeters) will be indicated on

the y axis - 1 cm on the axis represents 1 cm of plant height.

After 1 week the height is 2 cm; this is indicated on the graph with A, after 2 weeks, the height is 5 cm, see B, and after 3 weeks the height is 10 cm, see C.

Preparing planting, (Time = 0) the height is zero see D.

Now connect the crosses with a straight line. The line indicates the growth rate of the plant; this is the height increase over time.

Growth rate of corn plant

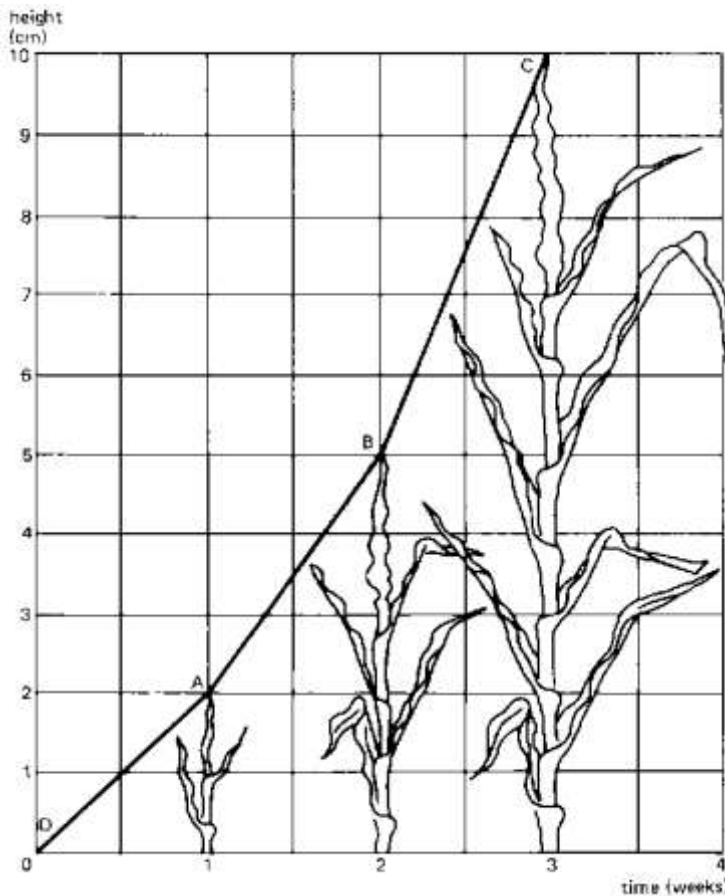

It can be seen from the graph that the plant is growing faster and faster (during the first week 2 cm and during the third week 5 cm). The line from B to C is steeper than the line from D to A. The height of the plant after planting can be read from the graph.

See the dotted line. Locate on the horizontal axis 2 1/2 weeks, and follow the dotted line upwards until the dotted line crosses the graph. From this crossing, follow the dotted line to the left until the vertical axis is reached. Now take: 7.5 cm, which means that the plant had a height of 7.5 cm after 2 1/2 weeks. This height has not been measured in reality, but with the graph the height can be determined.

QUESTION

What was the height of the plant after 1 1/2 weeks?

ANSWER

The height of the plant after 1 1/2 weeks is 3.5 cm.

Graph of the growth rate of a corn plant

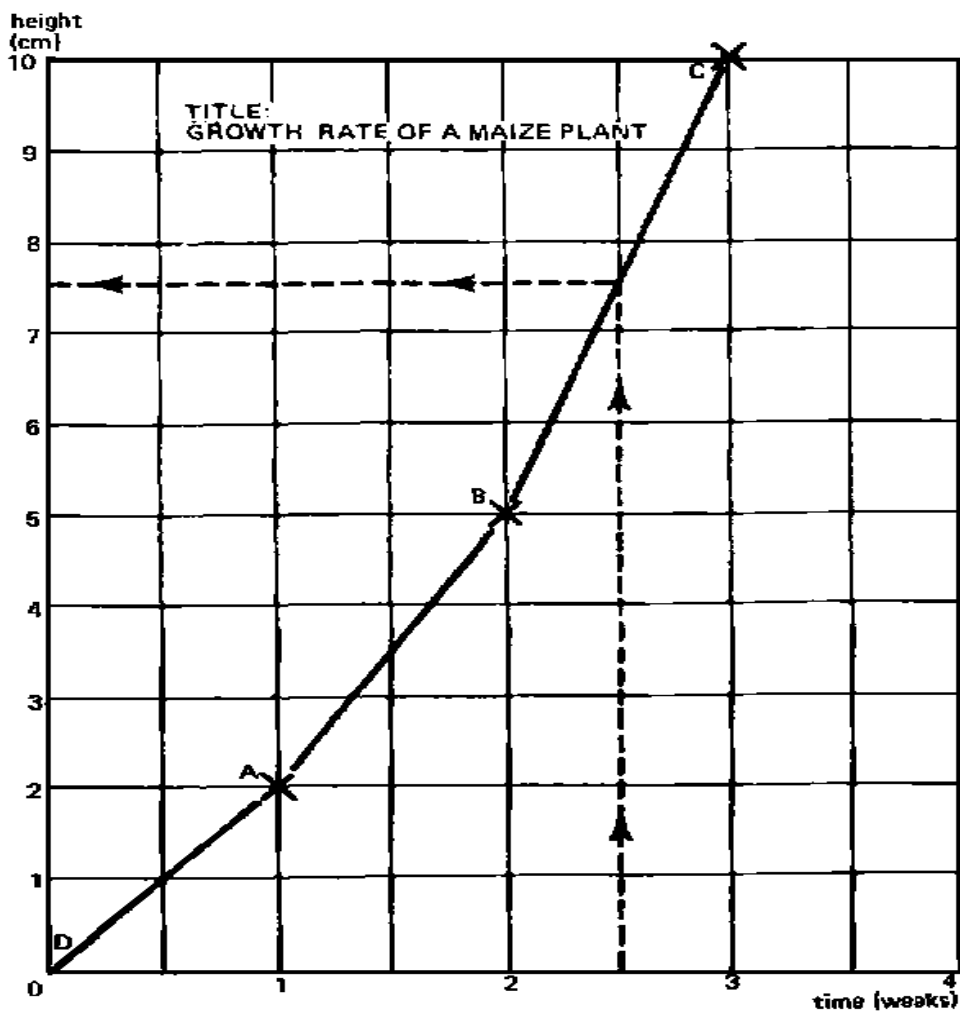

EXAMPLE 2

Another example to illustrate how a graph should be made is the variation of the temperature over one full day (24 hours). Suppose the outside temperature (always in the shade) is measured with a thermometer every two hours, starting at midnight and ending the following midnight.

Suppose the following results are found:

Time (hr)	Temperature (°C)
0	16
2	13
4	6
6	8
8	13
10	19
12	24
14	28
16	2
18	27
20	22
22	19
24	16

On the x axis, indicate the time in hours, whereby 1 cm on the graph is 2 hours. On the y axis, indicate the temperature in degrees Celsius (°C), whereby 1 cm on the graph is 5°C.

Now indicate (with crosses) the values from the table (above) on the graph paper and connect the crosses with straight dotted lines.

Graph showing temperature over 24 hours; mistake 16 hour reading

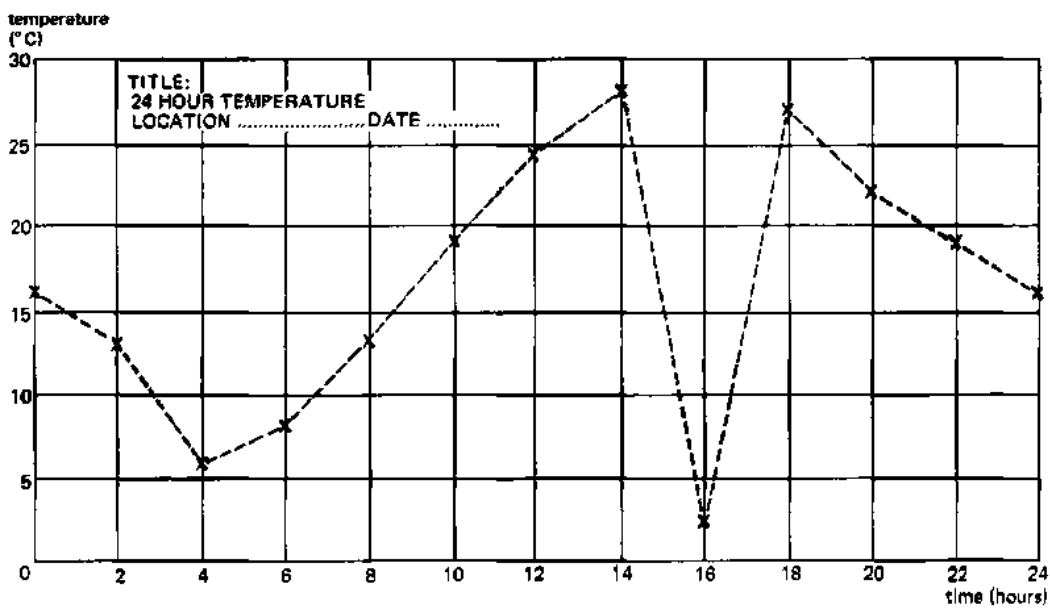

At this stage, if you look attentively at the graph, you will note that there is a very abrupt change in its shape around the sixteenth hour. The outside temperature seems to have fallen from 28°C to 2°C in two hours' time. That does not make sense, and the reading of the thermometer at the sixteenth hour must have been wrong. This cross cannot be taken into consideration for the graph and should be rejected. The only dotted line we can accept is the straight one in between the reading at the fourteenth hour, and the reading at the eighteenth hour.

Graph showing temperature over 24 hours; estimated correction of mistake

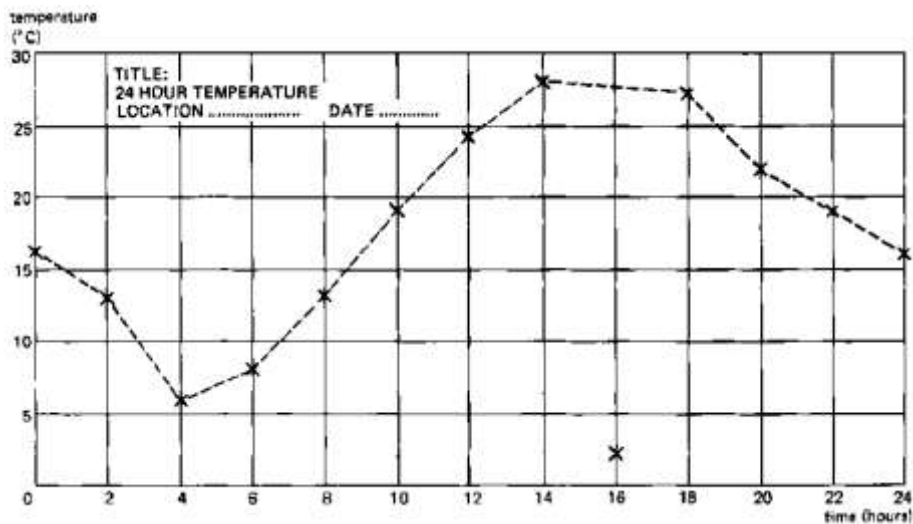

In reality, the temperature will change more gradually than what is indicated by the dotted line; that is why a smooth curve is made (continuous line). The smooth curve represents the most realistic approximation of the temperature over 24 hours.

Graph showing temperature over 24 hours; smooth curve

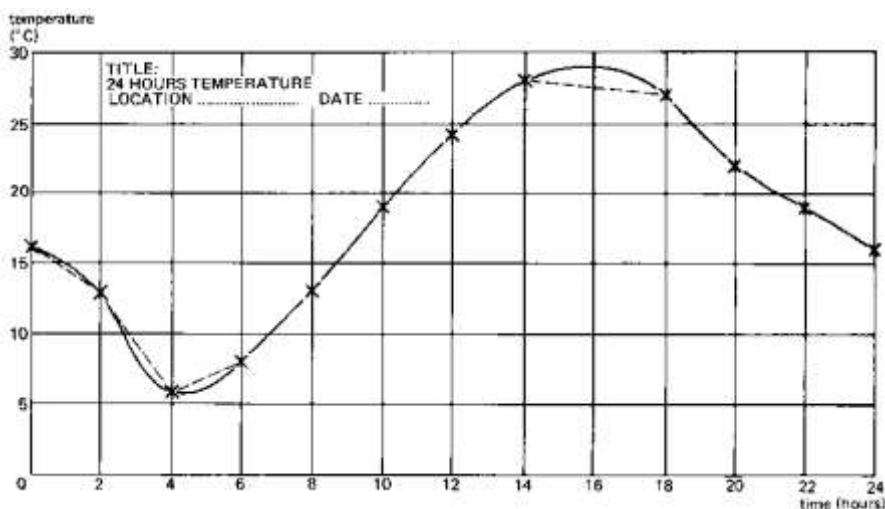

From the graph, it can be seen that the minimum or lowest temperature was reached around 4 o'clock in the morning and was about 6°C. The highest temperature was reached at 4 o'clock in the afternoon and was approximately 29°C.

QUESTION

What was the temperature at 7,15 and 23 hours? (Always use the smooth curve to take the readings).

ANSWER

Temperature at 7 hours: 10°C
Temperature at 15 hours: 29°C
Temperature at 23 hours: 17°C



How Much Have You Learned?

Self-Check 2.1

Convert the following:

1. 1m=___cm
2. 400cm=_____m
3. 5km=_____m
4. 1km=_____cm
5. 2000 m=___km

Find the area (hectare) of the following.

1. 600m x 600m
2. 100mx1000m
3. 200mx300m
4. 300mx400m
5. 500mx600m

Compute the following:

1. 6% of 100 plants were replaced
2. 15% of 28 hectares are harvested
3. 80% of 90 farmers are present
4. 50% of P200 increase in farmers salary
5. 5% of 100 kg seeds are dormant

Refer to the Answer Key. What is your score?



How Do You Apply What You Learned?

Show that you have learned something by doing this activity

Activity Sheet 2.1

PROJECT PROPOSAL

Materials/Tools:

- Mathematics Books
- Ruler
- Calculators
- Relevant tools and equipment for basic calculations

SPECIFIC INSTRUCTIONS:

1. Get a copy of a simple project proposal from any source (it is suggested that your choice is related to horticulture).
2. Study the different parts and make your own version.
3. Project proposal should include the following:
 - Preparing the operating statement and cash flow.
 - Computing for the total sales, total expenses and net profit or net loss.
 - Computing fertilizer amount of fertilizer
4. Submit your proposal before the end of the quarter or grading period.



How Well Did You Perform?

**Find out by accomplishing the Scoring Rubric honestly and sincerely.
Remember it is your learning at stake!**

While performing the activity it is important that you to assess your performance following the criteria below:

Criteria	Score			
	20	15	10	5
Project proposal should be simple and easy to understand				
Project proposal should be related to your course				
Data should be reliable and applicable (prices)				
Sample of project plan should be taken from a reliable source				

Interpretation of Scores:

- 16 – 20 – Excellent output
- 11 – 15 – Very good
- 6 – 10 – Fair output
- 5 and below – Poor output



**Congratulations! You did a great job!
Rest and relax a while then move on
to the next lesson. Good luck!**

REFERENCES

LO1

- Agricultural Arts for Secondary
- Growing Rich, Tasty Veggies in Harmony with Nature, vol. 1 by Jef Van Haute-Lyds Quileste Van Haute p.117-120
- <http://www.antiquefarmtools.info>
- <http://www.cdc.gov/niosh/pdfs/01-111b>
- <http://www.ebc.com.au>
- http://www.google.com.ph/search?q=land+preparation&hl=tl&rlz=1C1AVSX_enPH406PH406&site=webhp&prmd=imvns&tbm=isch&tbo=u&source=univ&sa=X&ei=lhNGT4SeOIK4iQf2lY2nDg&ved=0CF8QsAQ&biw=1366&bih=677

LO 2

- <http://library.thinkquest.org/TQ0312380/machine.htm>
- <http://www.agmachine.com/xmmd43d.htm>
- <http://www.fao.org/docrep/R4082E/r4082e02.htm#1.1%20introduction%20to%20surface%20area>

LESSON 3

Interpret Plans and Drawings



LEARNING OUTCOMES:

At the end of this Lesson you are expected to do the following:

- LO 1. interpret farm plans and layout; and
- LO 2. interpret irrigation plan.



Definition of Terms

Filler-a temporary plant, usually small and early, bearing one that is planted in between permanent plants

Planting board- a device used in lay-outing the area for the crops

Lay-outing- the act of locating the position of plant in the orchard

Staking-the act of the placing of the pole to mark the position of the plant to be set

Orchard-an establishment where fruit bearing crops are grown.

Irrigation- the application of water to the soil by any other means than rainfall

LEARNING OUTCOME 1

Interpret farm plans and layout

PERFORMANCE STANDARDS

- Planting system should be interpreted according to established farm procedures.
- Farm plans and layout should be designed according to crop grown.
- Site should be staked according to planting plan/system



Materials

- Calculator
- Pencil
- Bond paper
- References



What Do You Already Know?

Determine how much you already know about interpreting farm plans and layout. Take this test.

Pretest LO 1

Interpret the drawing below:

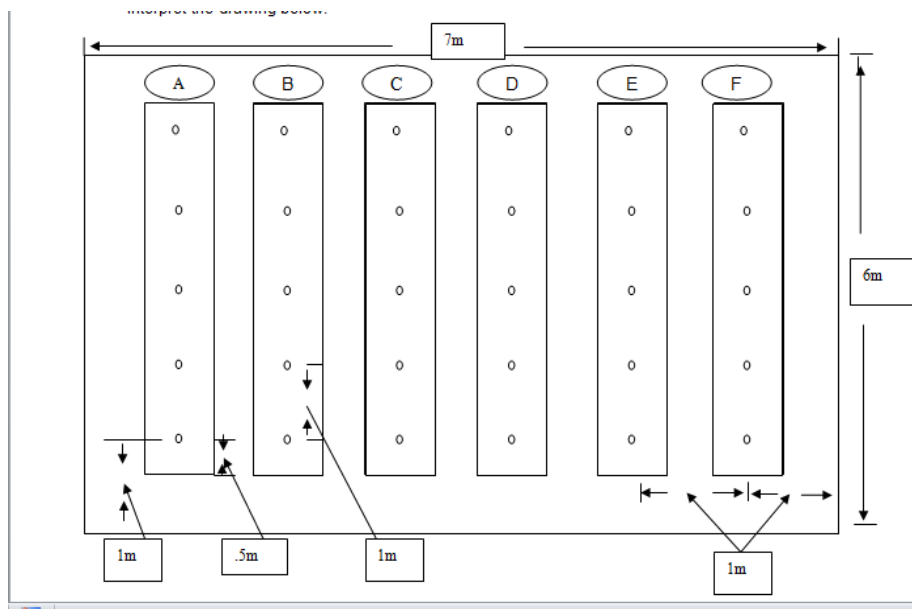

Legend:

○ Plant

MAKE YOUR INTERPRETATION:

1. What is the area?
2. How many rows are there in the area?
3. How many plants are there in a row?
4. How many plants are there in the area?
5. What is the distance between each plant per row?
6. What is the distance of plants between the hills?
7. How many plants are there in row A?
8. What is the length of the area?
9. What is the width of the area?
10. How many plants are needed in rows A,B and C?



What Do You Need To Know?

Read the Information Sheet 1.1 Find out how much you can remember and how much you learned by doing Self-check 1.1.

Information Sheet 1.1

INTERPRET FARM PLANS AND LAYOUTS

The 'Farming for the Future' (FFTF) program can help you to plan the best farm layout. It is an initiative of the NSW Government agencies focusing on whole farm planning. A whole farm plan considers the farm's physical, financial, and human/personal resources for both now and the future.

Site assessment

An on-site assessment of a farm is necessary, so that a map can be drawn according to the property's topography, boundaries, soil, water resources, and so on. A site assessment also will allow the formulation of a farm business plan.

Government plans

Acquaint yourself with the Regional Environmental Plans (REPs), Local Environmental Plans (LEPs), and Development Control Plans (DCPs) include their short and long-term effects on your proposed or existing farm enterprise. This will help to reduce unforeseen risks, and enhance your farm business. Council's building approval or development consent (DAs) may be needed for siting greenhouses, siting and constructing dams, or erecting hail and windbreak netting. Council approval to clear land or a 'no burning of crop debris or waste materials on farm' may apply. Consent will be required if odor or noise is a nuisance likely to be generated from the development.

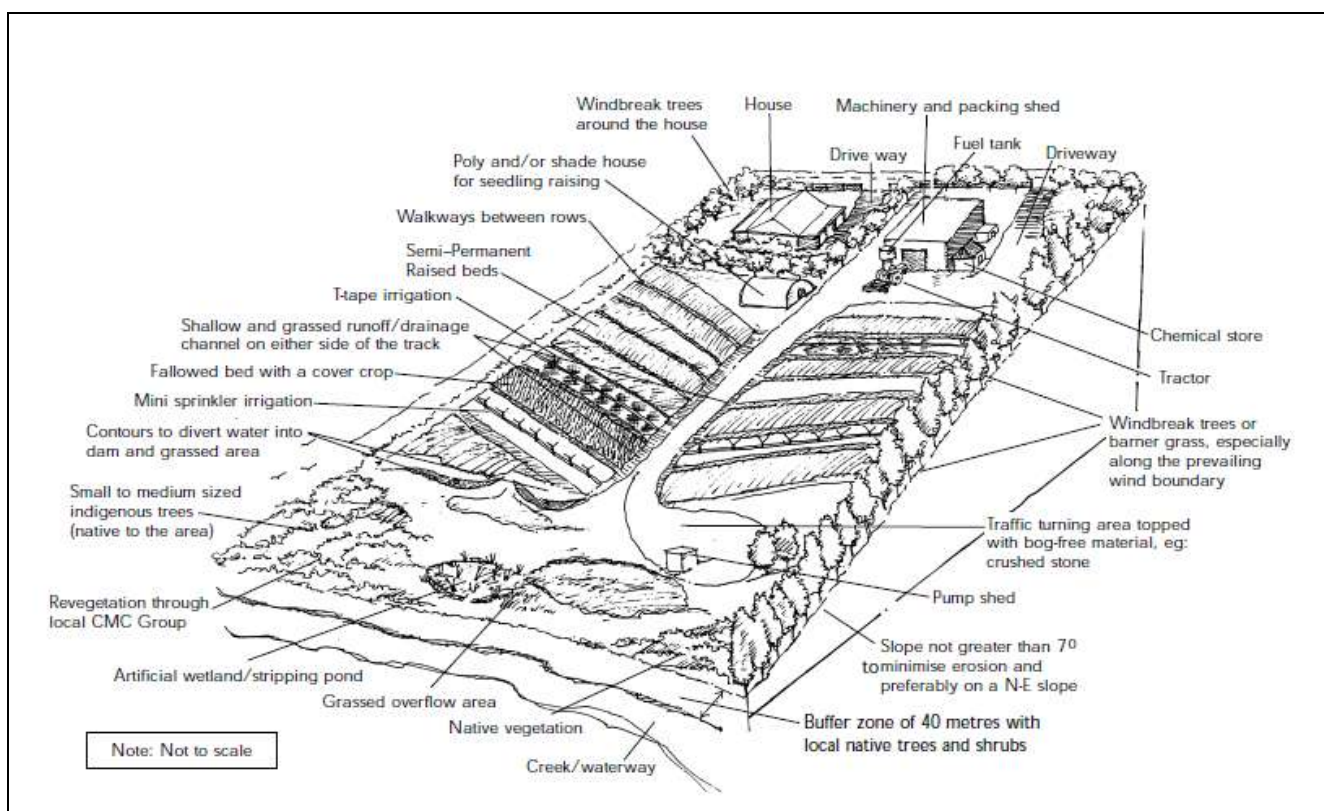

Desirable Layout of Vegetable Farm

Site selection

Site selection is important. Slopes to the northeast are preferred for maximum sunlight, warmth, and protection from wind. Slopes are prone to erosion and need to be farmed with care. To prevent soil erosion and the silting of waterways, do not grow vegetables on slopes greater than seven degrees (7°).

Buffer zones

Buffer zones are areas of vegetated land needed to be established or left in place to protect sensitive environmental areas and provide a habitat/sanctuary for wildlife. They should be located between the area of farm activity, and any areas of possible water quality impairment or contamination. Water environs or features to be protected are:

- **Riparian areas** include flood plains, adjacent to rivers and streams and other watercourses.
- **Wetlands** (the areas of land that are either temporarily or permanently covered with shallow water, and which play a crucial role in nutrient recycling). Wetlands have a high ecological productivity and should not be drained, filled or used as storages.
- **Drainage lines.** Maintain your creek. Leave a strip of uncleared native vegetation between the top of the bank and your farming activities for at least 20 m for small streams and 50–100 m for rivers like the Hawkesbury–Nepean. This buffer zone will intercept and filter farm chemical and nutrient run-off.

Soil types

Soil types should be suitable for the crop being grown. The better soil types are deep, well-drained sands, sandy loams and loams. Heavy clays are much less suitable as they drain poorly and waterlog easily. If in doubt have a physical test of the soil type.

Groundwater contamination

Check for groundwater contamination. Any contamination of the groundwater by pollutants can affect your farm business operations. Although well-drained soils are preferred for growing vegetables, there is a greater risk that pesticides, herbicides and fertilizer can leach through them and contaminate groundwater resources.

Windbreaks

Wind protection and screening of the whole farm and of individual large paddocks is recommended. Screening of the property, especially with trees, prevents many complaints about farm activities. Windbreaks also prevent drift and movement of sprays, dust, pests, and noise to adjoining areas.

Soil management

You need to plan your soil management strategies. It is important to provide good drainage and install grassed drainage/ waterways in conjunction with fields designed to prevent erosion from irrigation and heavy rain. To prevent soil erosion on a 3° slope on Hawkesbury sandstone derived soils (sandy clay loam), you will need contour banks at intervals of 50 m. The Soil and Vegetation Management Directorate of DLWC offers expert advice in this area.

Water management

Water management strategies require pre-cropping assessment. Water supplies must be able to meet the needs of crops in periods of drought when water demand is the highest. Inadequately designed water supplies will limit crop production and profitability.

Salt Tolerance of Vegetable Crops						
Crop	Expected reduction in yield					
	Nil loss EC Salts (dS/m)	Total Soluble Salts (ppm)	10%loss EC (dS/m)	Total Soluble Salts (ppm)	25%loss EC (dS/m)	Total Soluble Salts (ppm)
Beans (green/french)	0.7	450	1.0	640	1.5	960
Broad beans	1.5	960	-	-	-	-
Broccoli	1.9	1220	2.6	1660	3.7	2370
Cabbage	1.2	770	1.9	1220	2.9	1860
Cantaloupe	1.5	960	2.4	1540	3.8	2430
Capsicum	1.0	640	1.5	960	2.2	1410
Carrots	0.7	450	1.1	700	1.9	1220
Cucumber	1.7	1090	2.2	1410	2.9	1860
Lettuce	0.9	580	1.4	900	2.1	1340
Onion	0.8	510	1.2	770	1.8	1150
Potato	1.1	700	1.7	1090	2.5	1600
Radish	0.8	510	1.3	830	2.1	1340
Spinach	1.3	830	2.2	1410	3.5	2240
Sweet Corn	1.1	700	1.7	1090	2.5	1600
Tomato	1.7	1090	2.3	1470	3.4	2180
Watermelon	1.3	830	-	-	-	-

Water quality is also important. Poor water quality reduces the growth and yield of crops. Using poor quality water can damage both the physical and chemical properties of the soil. Avoid high-volume sprinklers and flood irrigation in areas of high soil water salinity where the water table is rising. In such situations use low volume mini sprinklers or drip irrigation and irrigate at night.



How Much Have You Learned?

Self-Check 1.1

TRUE OR FALSE

1. Slopes to the south-west are preferred for maximum sunlight, warmth and protection from wind.
2. To prevent soil erosion and the silting of waterways, do not grow vegetables on slopes greater than 7°.
3. The screening of the property, especially with trees, prevents many complaints about farm activities.
4. Windbreaks also prevent drift and movement of sprays, dust, pests, and noise to adjoining areas.
5. Poor water quality increases the growth and yield of crops.
6. Using poor quality water can damage both the physical and chemical properties of the soil.
7. Avoid high-volume sprinkler and flood irrigation in areas of high soil water salinity where the water table is rising.
8. A whole farm plan considers the farm's physical, financial and human/personal resources for both now and the future.
9. Water management strategies require pre-cropping assessment.
10. Inadequately designed water supplies will enhance crop production and profitability.

Read the Information Sheet 1.2 very well. Then find out how much you can remember and how much you have learned by doing Self-check 1.2.

Information Sheet 1.2

ORCHARD PLANTING AND PLANTING DESIGNS

LAYOUTING

The layout of an orchard is very important. Layouting means fixing the position of trees, roads, buildings, etc. in an orchard being planned. There are various systems of layout in an orchard. Systems of layout refer to the design of planting the trees. It is desirable to have the trees planted in a systematic way because: (1) orchard operations like intercultural and irrigation are carried out easily; (2) it makes possible the distribution of areas equally for each tree; (3) it results in maximum utilization of an area according to different kinds of trees; and (4) it makes supervision more easy and effective.

Systems of Planting

There are five systems of planting fruit trees. In all these systems, trees are planted in rows. The distance between row to row and plant to plant varies with the system, type of fruit trees and their varieties. Trees with bigger canopy require greater distance between them and vice versa.

A. Square system

In square system, the trees are planted in four corners of a square keeping the same distance between rows and from plant to plant in the same row. This is the simplest and easiest system of plantation.

Advantages

1. Irrigation channels and paths can be made straight.
2. Operations like plowing, harrowing, cultivation, spraying, and harvesting becomes easy.
3. Better supervision of the orchard is possible as one gets a view of the orchard from one end to the other.

Disadvantages

1. The number of trees that can be accommodated will be lessened.
2. The distance between plant to plant and row to row remains the same, hence, a certain amount of space in the middle of four trees is wasted.

B. Rectangular system

In a rectangular system the trees, are planted in the same way as in a square system,

except that the distance between rows will be more than the distance between plants in the same row. Four adjacent trees in this system make a rectangular design.

Advantages

1. Intercultural operations can be carried out easily.
2. Irrigation channel can be made length and breadth wise
3. Light can penetrate into the orchard through the large inter spaces between rows.
4. Better supervision is possible.
5. Intercropping is possible.

Disadvantages

1. A large area of the orchard between rows is wasted if intercropping is not practiced.
2. Less number of trees are planted.

C. Quincunx or Diagonal system

Basically, a quincunx or diagonal system is the same as the square system except, for the addition of a tree in the center of each square. In this system, the number of trees planted in the same area is almost doubled. But the distance between the trees is much reduced. For this reason, trees with shorter are chosen for the center. By the time the main trees grow into full size, the central trees will have finished their life cycle. The central trees are known as filler crops and the others as main crops. If the filler crops hinders seriously the growth of main trees, it should be removed. Papaya, Guava, Lime, plum and peaches are a few examples of filler crops in orchards with trees like mango jack and tamarind.

Advantages

1. Additional income can be earned from the filler crop until the main crop comes into bearing.
2. Compared to square to square and rectangular systems, almost double the number of trees can be planted initially.
3. Maximum utilization of the land is possible.

Disadvantages

1. Skill is required to layout the orchard.
2. Inter/filler crop can interfere with the growth of the main crop.
3. Intercultural operations become difficult.
4. Spacing of the main crop is reduced if the filler crop is allowed to continue after the growth of the main crop.

D. Hexagonal system

In the hexagonal system, the trees are planted at the corners of an equilateral triangle. Six such triangles are joined together to form a hexagon. Six trees are positioned at the corners of this hexagon with a seventh in the center all arranged in the three rows. However the distance between tree to tree in six directions from the central tree remains the same.

Advantages

1. Compared to square system 15% more trees can be planted.
2. It is an ideal system for the fertile and well irrigated land.
3. Plant to plant distance can be maintained the same.
4. More income can be obtained.

Disadvantages

1. Intercultural operations become difficult.
2. Skill is required to layout the orchard.

E. Contour system

Contour is an imaginary line connecting all points of equal elevation across a slope. In a hilly area, a lot of depressions, ridges, furrows, and place surface are found. But when planting is done, a line is made by connecting all the points of the same elevation across the slope from a base line. This spacing is maintained on this row. However, row to row distance will not be the same since the degree of slope varies from spot to spot. Points of equal elevation at a distance and spacing marked from equal plant to plant equal to plant to plant spacing are marked with the help of Dumpy level or other suitable instrument.

In these system contour lines themselves become the rows and are marked at the row to row distance. However, it is not possible to maintain the row to row distance strictly all long the rows. Whenever distance between adjacent contour line is almost double, another contour is fitted in that space.

Advantages

1. This system can be adopted in hilly regions and in leveled land.
2. Contour system can control the soil erosion.
3. It helps simultaneously in the conservation of water.
4. Preservation of plant nutrients supplied by manures and fertilizers is possible.
5. Contours from an easy path movements on the hill slopes are used for carrying out various orchard operations such as weeding, manuring, pruning, harvesting, disease and pest control.

Disadvantages

1. The laying out of contour lines is difficult and time consuming.
2. Special skill is required to layout this system.
3. Special instruments are required for making contour lines.
4. The row to row distance will not be equal and adjustments may be required in the plant to plat distance.
5. Rows are broken in to bits and pieces.

Procedure for layout

In the layout procedures for different system, a few common steps can be identified.

1. Measure the land.
2. Decide the types of trees to be planted. The planting distance and the system of plating.
3. Prepare a plan on the paper, and making all details

Preparing a plan on paper is tedious and time consuming, but the actual layout becomes easier.

A base line (parallel to any side of the plot or a contour line) is marketed always at the beginning of the layout, forming a row of trees. Subsequent rows are marked parallel to this base line except in the contour system. The position of the trees in each row is marked using the wooden pegs, leaving a space that is equal to half the plant to plant distance on either side (boundary). Otherwise, the roots and canopy of the trees may spread beyond the boundary. Depending on the length and width of the land, plant to plant and row to row distances, boundary space may be reasonably adjusted. While preparing the blue print, all these factors are taken into consideration.



How Much Have You Learned?

Self-Check 1.2

A. Square system

Advantages

1. _____.
2. _____.
3. _____.

Disadvantages

1. _____.
2. _____.

B. Rectangular system

Advantages

1. _____.
2. _____.
3. _____.
4. _____.
5. _____.

Disadvantages

1. _____.
2. _____.

C. Quincunx or Diagonal system

1. _____.
2. _____.

Advantages

1. _____.
2. _____.

3. _____.

Disadvantages

1. _____.

2. _____.

3. _____.

4. _____.

D. Hexagonal system

Advantages

1. _____.

2. _____.

3. _____.

4. _____.

Disadvantages

1. _____.

2. _____.

E. Contour system

Advantages

1. _____.

2. _____.

3. _____.

4. _____.

5. _____.

Disadvantages

1. _____.

2. _____.

3. _____.

4. _____.

5. _____.

Refer to the Answer Key. What is your score?



How Do You Apply What You Learned?

Show that you learned something by doing this activity

Activity Sheet 1.1

Layout Garden Plots

Materials needed:

Quantity	Description
2 sheets	Bond paper short
1 pc	Pencil
1 pc	Ruler

INSTRUCTIONS:

1. Draw one inch border lines on your bond paper
2. Use the following data in making your layout
Imagine that 1 cm on your drawing is equivalent to 1m
 - A. Width= 16 m
 - B. Length=19 m
 - C. Planting distance
Between row=1m
Between hill=.5 m
3. Sketch inside the border lines to your plot layout
4. Submit your output to your teacher

Activity Sheet 1.2

Sketch Orchard Plan

Materials needed:

Quantity	Description
1 sheet	Manila paper
1 pc	Pencil
1 pc	Ruler
1 unit	Calculator
1 pc	Meter Stick

INSTRUCTIONS:

1. Measure the length and width of the manila paper using a ruler to get the area.
2. Imagine that 5 inches from the actual measurement of the manila paper is equivalent to 1 meter of the actual field.
3. Consider the following data.
 - **Planting system to be used** : square system
 - The **Area** depends on the measurement of your manila paper
 - **Distance of planting**: 10 meters



How Well Did You Perform?

**Find out by accomplishing the Scoring Rubric honestly and sincerely.
Remember it is your learning at stake!**

For Activity 1.1

Criteria	Score			
	20	15	10	5
Accuracy 70%				
Presentation 20%				
Neatness 10 %				

For Activity 1.2

Criteria	Score			
	20	15	10	5
Accuracy 70%				
Presentation 20%				
Neatness 10 %				

Interpretation of Scores:

- 16 – 20 – Excellent output
- 11 – 15 – Very good
- 6 – 10 – Fair output
- 5 and below – Poor output

LEARNING OUTCOME 2

Interpret irrigation plan and design

PERFORMANCE STANDARDS

- The irrigation system plan is interpreted according to established procedures.
- Different designs of irrigation systems are enumerated according to standard procedures.



Materials

- Irrigation plan
- Bond paper
- Pencil
- References



What Do You Already Know?

Determine how much you already know about interpreting the irrigation plan and the design. Take this test.

Pretest LO 2

Enumerate the following:

(2) FUNCTIONS OF FARM IRRIGATION SYSTEMS

1. _____
2. _____

(3) ESSENTIAL FEATURES OF A PLAN

1. _____
2. _____
3. _____

(2) Types of Conventional Sprinkler Systems

1. _____
2. _____

(3) Advantages of drip or trickle irrigation

1. _____
2. _____
3. _____



What Do You Need To Know?

Read the Information Sheet 2.1 very well. Then find out how much you can remember and how much you have learned by doing Self-check 1.1.

Information Sheet 2.1

Irrigation System Plan and Design

Water required by crops is supplied by nature in the form of precipitation, but when it becomes scarce or when its distribution does not coincide with demand peaks, it is then necessary to supply it artificially, by irrigation. Several irrigation methods are available, and the selection of one depends on factors such as water availability, crop, soil characteristics, land topography, and associated cost.

Proper design of an irrigation system requires that the pumping system precisely match the irrigation distribution system, so that the pressure and flow rate required can be efficiently provided by the pumping system. The energy required to pump water is determined by the total dynamic head (water lift, pipe friction, system pressure, etc.), the water flow rate desired, and the pumping system's efficiency.

Irrigation water management involves determining when to irrigate, the amount of water to supply each irrigation event and during each stage of plant, and operating and maintaining the irrigation system. The main management objective is to manage the production system for profit it should be without compromising the environment and in agreement with water availability. A major management activity involves irrigation scheduling or determining when and how much water to apply, and considering the irrigation method and other field characteristics.

FUNCTIONS OF FARM IRRIGATION SYSTEMS

The primary function of farm irrigation systems is to supply crops with irrigation water in the quantities at the time it is needed. Specific functions includes:

1. Diverting water from the water source.
2. Conveying it to individual fields within the farm.
3. Distributing it within each field.
4. Providing a means for measuring and regulating flows.

Other functions of farm irrigation system include crop and soil cooling, protecting crops from frost damage, delaying fruit and bud development, and controlling wind erosion, providing water for seed germination, application of chemicals, and land application of wastes.

REASONS FOR AN IRRIGATION PLAN

- A project plan enables the designer to lay out the irrigation system in the most cost effective way. The plan is used to generate a material list and to evaluate the anticipated project costs.
- The plan provides a step by step information on system installation. Information on crop spacing, sprinklers, pumping requirements, pipeline sizes and lengths should be included in the plan. Pertinent obstructions such as roads, trees, gas, oil, water, telephone, or transmission lines must also be indicated.
- Specification, design standards, and work schedules and set out in a plan on the basis of any contractual agreements between the installation contractor and the farmer.
- The plan provides a record for future reference. It can be used for overall farm planning and it identifies the limits of expansion potential.

ESSENTIAL FEATURES OF A PLAN

- **Topographic Data** - The field shape must be accurately drawn showing pertinent obstructions, features and elevation details.
- **Water Source Capacity** - The water supply must be clearly indicated showing location and available capacity.
- **Depending on the water source, a well log or water license must accompany the irrigation plan.** Irrigation reservoirs also require Water Management Branch licensing.
- **Soil and Crop Characteristics** - Soil and crop limitations must be accounted for to reduce runoff and deep percolation by mismanagement of the irrigation system.
- **Design Parameters** - Soil water holding capacity, maximum application rate and climatic data must be used to select the correct irrigation system design.
- **Design Data** - The nozzle selected, operating pressure, discharge rate and sprinkler spacing must all be shown on the plan. The irrigation interval, set time, application rate and net amount applied must also be calculated.

WHERE TO OBTAIN A PLAN

A farm irrigation plan can be obtained from irrigation engineering consultants as well as reputable irrigation equipment dealers. The features of a farm irrigation plan are summarized in the sample "Sprinkler Irrigation Design Information" sheets attached. A sample of an irrigation design plan is also included.

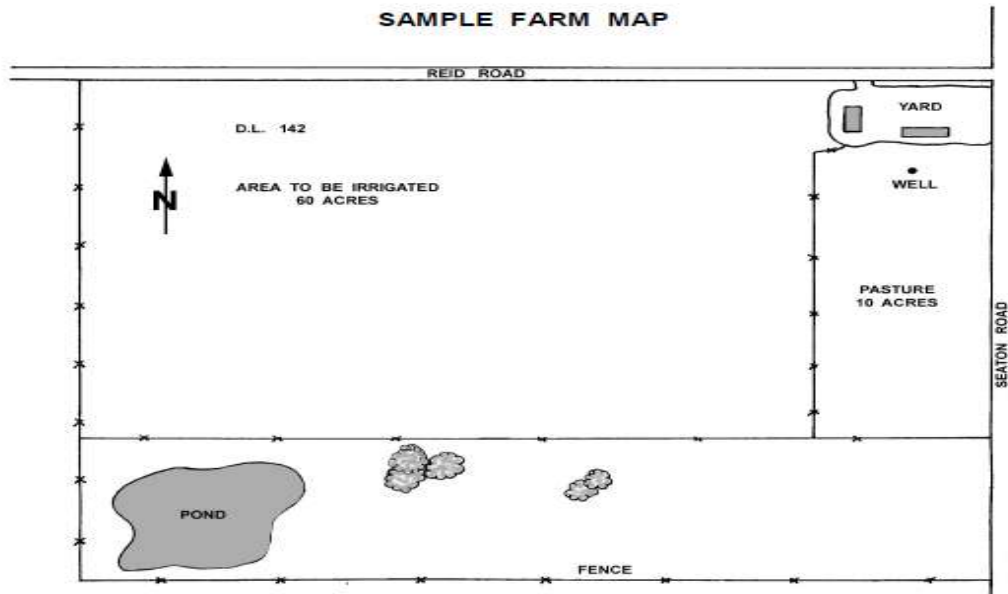

How Much Have You Learned?

Self-Check 2.1

(4) FUNCTIONS OF FARM IRRIGATION SYSTEMS

1. _____
2. _____
3. _____
4. _____

(6) ESSENTIAL FEATURES OF A PLAN

1. _____
2. _____
3. _____
4. _____
5. _____
6. _____

Refer to the Answer Key. What is your score?

Different Designs of Irrigation Systems

1. SURFACE IRRIGATION- Water is applied to the field in either the controlled or uncontrolled manner.

- 1.1 FURROW IRRIGATION- Only a part of the land surface (the furrow) is watered thus minimizing evaporation loss.

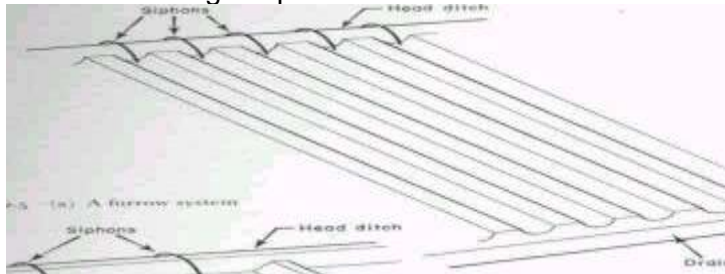

A. FURROW IRRIGATION BY CUTTING THE RIDGE

Fig. 91a. Water flows into the furrows through openings in the bank

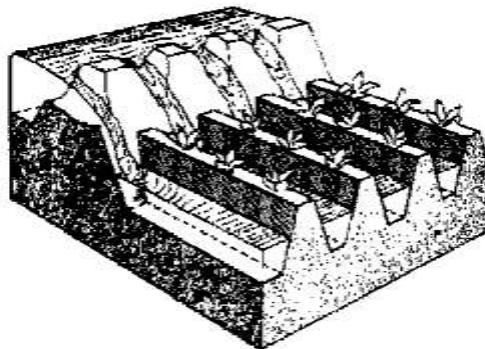

B. FURROW IRRIGATION WITH SIPHONS

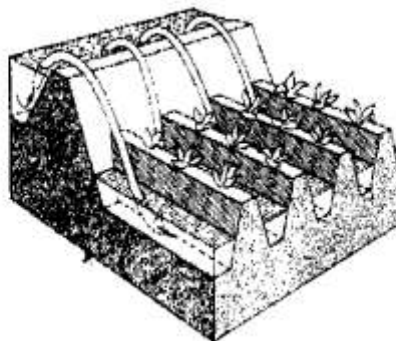

1.2. BORDER IRRIGATION SYSTEM

1. In a border irrigation, controlled surface flooding is practiced where the field is divided into strips by parallel ridges or dikes or each strip is irrigated separately by introducing water upstream and it progressively covers the entire strip.
2. Border irrigation is suitable for crops that can withstand flooding for a short time e.g. wheat.
3. It can be used for all crops, provided that the system is designed to provide the needed water control for irrigation of crops.
4. The amount of irrigation is suited to soil between extremely high and very low infiltration rates.
5. In border irrigation, water is applied slowly.
6. The root zone is applied water gradually down the field.
7. At a time, the application flow is cut-off to reduce water losses.
8. Ideally, there is no runoff and deep percolation.
9. Determining the time to cut off the inflow is difficult.

42

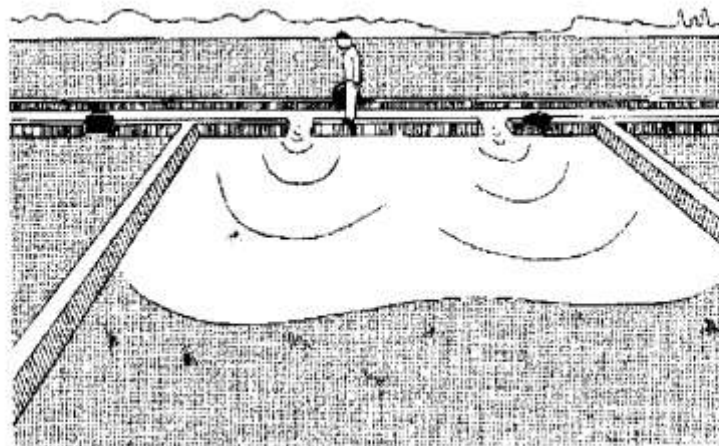
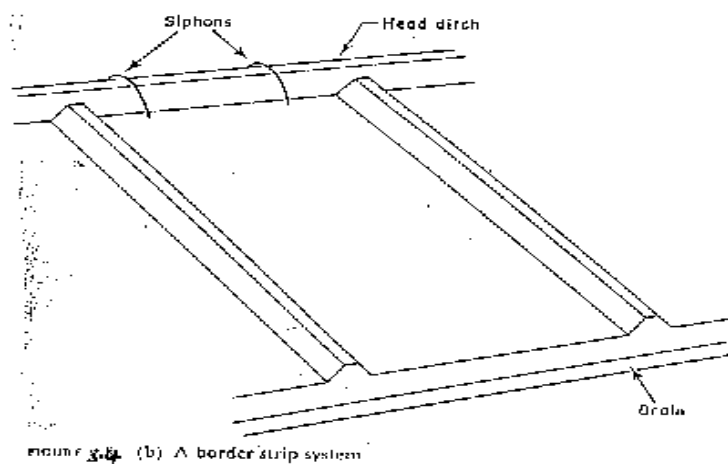

Design Parameters of Border Irrigation System

- a) Strip width:** Cross slopes must be eliminated by leveling.

Since there are no furrows to restrict lateral movement, any cross slope will make water move down one side leading to poor application efficiency and possibly erosion.

-The stream size available should also be considered in choosing a strip width.

-The size should be enough to allow complete lateral spreading throughout the length of the strip.

-The width of the strip for a given water supply is a function of the length

-The strip width should be at least bigger than the size of vehicle tract for construction where applicable.

b) Strip Slope: Longitudinal slopes should be almost similar to the furrow irrigation.

c) Construction of Levees: They should be big enough to withstand erosion, and levels of sufficient height to contain the irrigation stream.

d) Selection of the Advance Stream: The maximum advance stream used should be non-erosive, depending on the protection afforded by the crop cover. Clay soils are less susceptible to erosion, but suffer surface panning at high water velocities. Table 3.4 gives the maximum flows recommendable for bare soils.

e) The Length of the Strip: Typical lengths and widths for various flows are given in Table 3.5. The ideal lengths can be obtained by field tests.

1.3. Basin Irrigation System

In the basin irrigation system, water is flooded in wider areas. It is ideal for irrigating rice.

1. The area is normally flat.
2. In basin irrigation, a very high stream size is introduced into the basin so that rapid movement of water is obtained.
3. Water does not infiltrate a lot initially.
4. In the end, a bond is put and water can pond the field.
5. The opportunity time difference between the upward and the downward ends are reduced.

The size of basin is related to stream size and soil type.

Suggested basin areas for different soil types and rates of water flow

Flow rate		Soil Type			
		Sand	Sandy loam	Clay loam	Clay
l/s	m ³ /hrHectares.....			
30	108	0.02	0.06	0.12	0.20
60	216	0.04	0.12	0.24	0.40
90	324	0.06	0.18	0.36	0.60
120	432	0.08	0.24	0.48	0.80
150	540	0.10	0.30	0.60	1.00
180	648	0.12	0.36	0.72	1.20
210	756	0.14	0.42	0.84	1.40
240	864	0.16	0.48	0.96	1.60
300	1080	0.20	0.60	1.20	2.00

Note: The size of basin for clays is 10 times that of sand are the infiltration rate for clay is low, the leading to higher irrigation time. The size of basin also increases as the flow

rate increases. The table is only a guide and practical values from an area should be relied upon. There is the need for field evaluation.

Time-Distance Graph of the Basin System

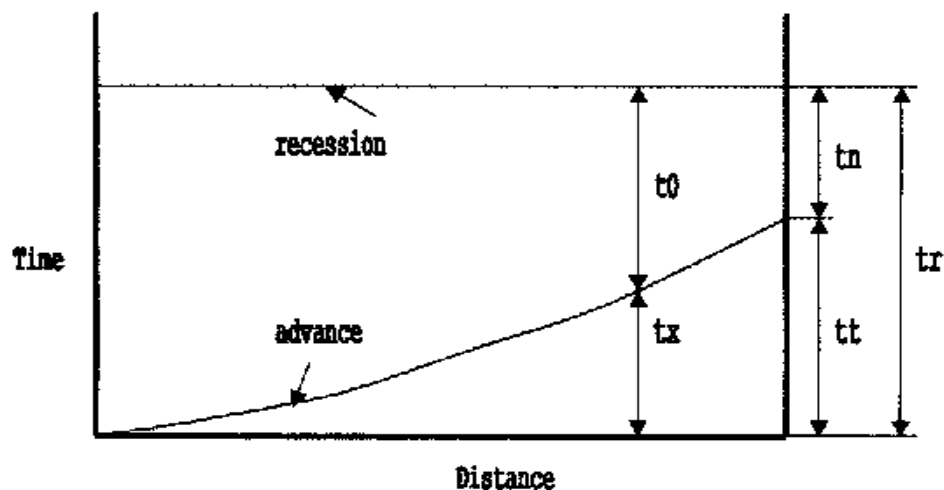

Figure 2.1. Definition sketch of advance and recession curves for a level basin (Clemmens and Dedrick, 1980)

Depth-Distance Graphs of the Basin Irrigation System

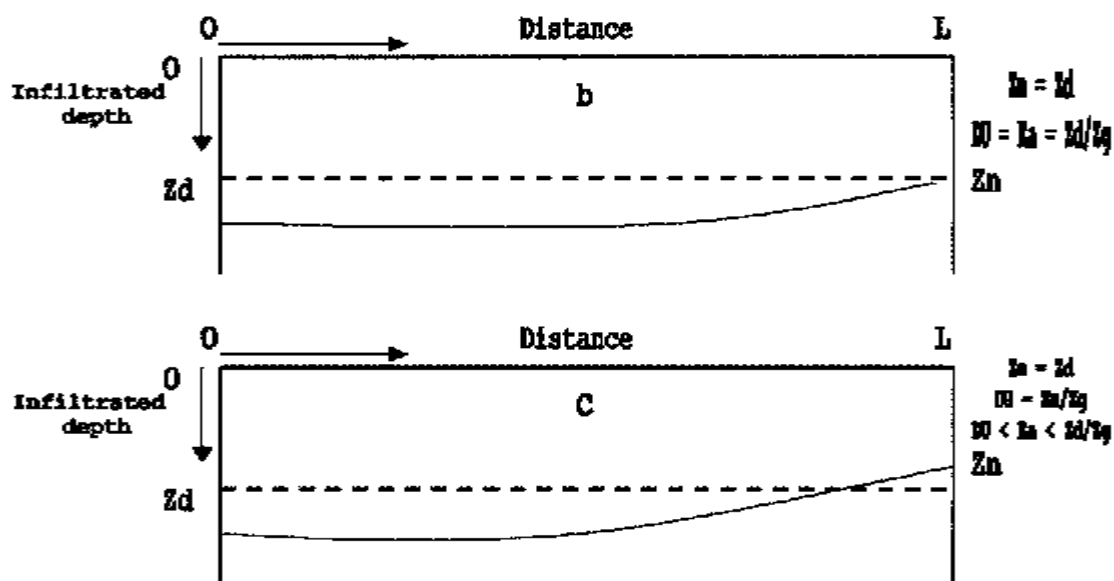

Figure 2.3. Profiles of infiltrated water: (a) for overirrigation throughout basin, (b) for adequate irrigation with no excess overirrigation, and (c) for slight

2. SPRINKLER IRRIGATION

The sprinkler system is ideal in areas where water is scarce.

A Sprinkler system conveys water through pipes and applies it with a minimum amount of loss.

-Water is applied in the form of sprays that sometimes simulate natural rainfall.

-The difference is that this simulated rainfall can be controlled in duration and intensity.

-If well planned, designed, and operated, it can be used in sloping land to reduce erosion where other systems are not possible.

Components of a Sprinkler Irrigation System

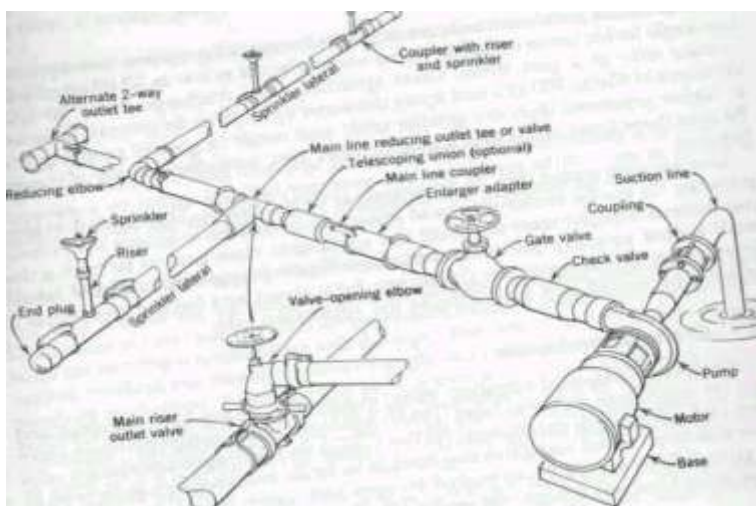

Types of Conventional Sprinkler Systems

a) Fully portable system: The laterals, mains, sub-mains, and the pumping plant are all portable.

The system is designed to be moved from one field to another or other pumping sites that are in the same field.

b) Semi-portable system: Water source and the pumping plant are fixed in location.

Other components can be moved.

The system cannot be moved from field to field or from farm to farm except when more than one fixed pumping plant is used.

c) Fully permanent system: Laterals, mains, sub-mains, as well as fixed pumping plant are permanently located.

Sometimes laterals and mainlines may be buried.

The sprinkler may be permanently located or moved along the lateral.

It can be used on permanent irrigation fields and for relatively high value crops e.g.

Orchards and vineyards.

Labor savings throughout the life of the system may later offset high installation cost.

3. DRIP OR TRICKLE IRRIGATION

ADVANTAGES:

1. Water is applied directly to the crop (ie. entire field is not wet)
2. Water is conserved.
3. Weeds are controlled, because only the places getting water can grow weeds.
4. There is a low pressure system.
5. There is a slow rate of water application somewhat matching the consumptive use.
Application rate can be as low as 1 - 12 l/hr.
6. In cases of reduced evaporation, only potential transpiration is considered.
7. There is no need for a drainage system.

Components of a Drip Irrigation System

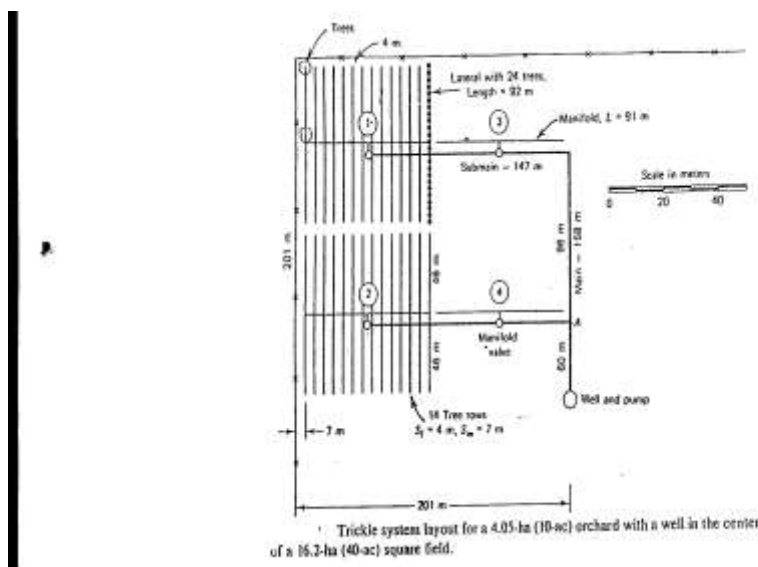
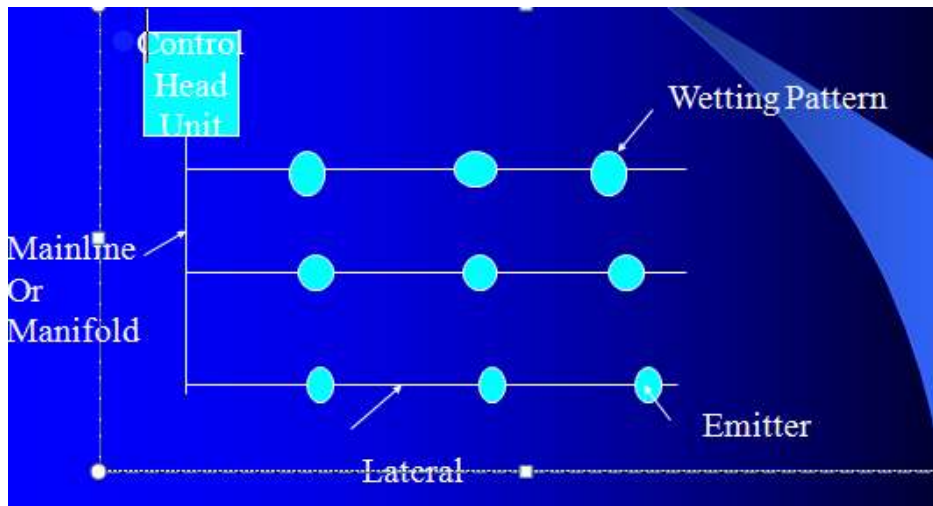



How Much Have You Learned?

Self-Check 2.2

Give the following:

(3) Types of Conventional Sprinkler Systems

1. _____
2. _____
3. _____

(7) Advantages of drip or trickle irrigation

1. _____
2. _____
3. _____
4. _____
5. _____
6. _____
7. _____

Refer to the Answer Key. What is your score?



How Do You Apply What You Learned?

Show that you learned something by doing this activity

Activity Sheet 2.1

Sketch Irrigation Plan

MATERIALS NEEDED:

Quantity	Description
2 sheets	Bond paper short
1 pc	Pencil
1 pc	Ruler

INSTRUCTIONS:

1. After knowing about different irrigation designs, select 1 design applicable in your area.
2. Using the materials above, sketch the irrigation design applicable in your locality.
3. Explain why did you considered this design on another sheet of bond paper
4. Submit your output to your teacher after 1 day.
5. Your teacher will ask you to present your work in front of your classmates.
6. Save your work for the next activity (activity 2.2).

Activity Sheet 2.2

CREATE MINIATURE IRRIGATION CANAL

MATERIALS NEEDED:

Quantity	Description
1 pc	Illustration board
10 bar	Activity clay

INSTRUCTIONS:

1. Your teacher will divide the class into groups (5 members in a group).
2. From your activity sheet 2.1. Select the best work among your group members.
3. Decide which work will serve as your model in creating your miniature irrigation canal.
4. You will be given one hour to finish your group activity.
5. Submit your output when it is already completed.



How Well Did You Perform?

Find out by accomplishing the Scoring Rubric honestly and sincerely.
Remember it is your learning at stake!

For Activity 2.1

Criteria	Score			
	20	15	10	5
Content 50%				
Applicability 20%				
Presentation 20%				
Neatness 10 %				

For Activity 2.2

Criteria	Score			
	20	15	10	5
Accuracy 50%				
Design 20%				
Presentation 20%				
Neatness 10 %				

Interpretation of Scores:

16 – 20 – Excellent output

11 – 15 – Very good

6 – 10 – Fair output

5 and below – Poor output



**Congratulations! You did a great job!
Rest and relax then move on to the
next lesson. Good luck!**

REFERENCES

LO1

- Horticulture CBLM
- Asuncion, Jr. Ramon G.; Elementary Agriculture: Saint Mary's Publishing. 1983
- Asuncion, Jr. Ramon G.; Introduction to Tropical Crop Production: First Edition: Saint Mary's Publishing. 1976
- Asuncion, Jr. Ramon G. et.al.; Technology and Home Economics 2: Agricultural Arts: First Edition: Abiva Publishing House, Inc: Quezon City. 1992
- Mendiola, N. B.; Principles of Crop Production: United Circulation, Inc.: Malabon, Rizal: 1959
- Technology and Home Economics 2 (SEDP Series)

LO 2

- Horticulture CBLM
- http://www.google.com.ph/search?q=IRRIGATION&hl=tl&rlz=1C1AVSX_enPH406PH406&prmd=imvnsb&tbm=isch&tbo=u&source=univ&sa=X&ei=NxxHT-fsFeOSiAeR35CXDg&ved=0CGUQsAQ

LESSON 4

Applying Safety Measures in Farm Operations



LEARNING OUTCOMES:

At the end of Lesson you are expected to do the following:

- LO 1. apply appropriate safety measures; and
- LO 2. safekeep/dispose tools, materials, and outfit.



Definition of Terms

Safety – deals with the physical or environmental conditions of work which comply with the prescribed Occupational Health Safety (OHS) standards, and allow the workers to perform their job without and within acceptable exposure to hazards.

Occupational safety- include the practices related to production and work process

Health- is a sound state of the body and mind of the worker that enables him or her to perform his job normally

Sharpening- the process of thinning the edge of the tools like knives, pruning shears, hedge shears, etc.

Cleaning- is the act or process of removing dirt from tools, containers and farm facilities.

Disinfection chemicals- refers to the chemical used in cleaning, which has the ability to kill microorganisms especially pathogens.

LEARNING OUTCOME 1

Apply appropriate safety measures

PERFORMANCE STANDARDS

- Safety measures are applied based on work requirement and farm procedures.
- Tools and materials are utilized in accordance with specification and procedures.
- Outfit is worn in accordance with farm requirements.
- Shelf life and or expiration of materials are effectively checked against manufacturer's specifications.
- Hazards in the workplace are identified and reported in line with farm guidelines
- Emergency and accidents are responded to and prevented.



Materials

- PPE
- References



What Do You Already Know?

Let us determine how much you already know about applying appropriate safety measures while working in the farm. Take this test.

Pretest LO 1

MULTIPLE CHOICE: Choose the best answer

1. It is the potential for harm, or adverse effect on an employee's health.
 - a. .Chemicals
 - b. Exposure
 - c. Risk
 - d. Hazard
2. It is the likelihood that a hazard will cause injury or ill health to anyone at or near a workplace.
 - a. Risk
 - b. Exposure
 - c. Hazard
 - d. .Chemicals
3. This occurs when a person comes into contact with a hazard.
 - a. Risk
 - b. Exposure
 - c. Hazard
 - d. Chemicals
4. This includes floors, stairs, work platforms, steps, ladders, fire, falling objects, slippery surfaces, manual handling (lifting, pushing, pulling), excessively loud and prolonged noise, vibration, heat and cold, radiation, poor lighting, ventilation, air quality.
 - a. Chemicals
 - b. Mechanical and/or electrical
 - c. Psychosocial environment
 - d. Physical
5. It includes electricity, machinery, equipment, pressure vessels, dangerous goods, fork lifts, cranes, hoists.
 - a. Mechanical and/or electrical
 - b. Chemicals
 - c. Biological
 - d. Psychosocial environment
6. It includes chemical substances such as acids or poisons and those that could lead to fire or explosion, like pesticides, herbicides, cleaning agents, dusts and fumes from various processes such as welding.
 - a. Chemicals
 - b. Psychosocial environment
 - c. Mechanical and/or electrical
 - d. Biological

7. It includes bacteria, viruses, mold, mildew, insects, vermin, animals
 - a. Biological
 - b. Chemicals
 - c. Mechanical and/or electrical
 - d. Psychosocial environment
8. It includes workplace stressors arising from a variety of sources.
 - a. Psychosocial environment
 - b. Biological
 - c. .Chemicals
 - d. Mechanical and/or electrical
9. It the physical or environmental conditions of work which comply with the prescribed Occupational Health Safety (OHS) standards and which allow the workers to perform his or her job without or within acceptable exposure to hazards.
 - a. Safety
 - b. Biological
 - c. Psychosocial environment
 - d. Chemicals
10. The practices related to production and work process are referred to as _____.
 - a. occupational safety
 - b. safety
 - c. psychosocial environment
 - d. biological



What Do You Need To Know?

Read the Information Sheet 1.1 Find out how much you can remember and how much you have learned by doing Self-check 1.1.

Information Sheet 1.1

APPLY APPROPRIATE SAFETY MEASURES WHILE WORKING IN FARM

INTRODUCTION:

Many hazards are present in the farm. If the farmers are not aware of these hazards these may cause injury to their body or may cause diseases and even death. A farmer should always apply appropriate safety measures while working in the farm. In this lesson, students with the guidance and supervision of their teacher should identify tasks that involve the use of chemicals and hazardous tools and equipment; determine the uses of Personal Protective Equipment (PPE) and determine farm emergency procedures regarding safety working environment.

HAZARD, RISK AND EXPOSURE IN THE FARM

Agricultural crop production deals with a lot of activities to be done in the different workplace. While performing these activities, we expose ourselves to a lot of risk. Workplace hazard is a major cause of accident, injury, or harm to a worker who performs such task. These hazards should be the major concern of all who are involved in a certain job or work.

It is important to distinguish hazard, risk and exposure when undertaking risk management.

- *Hazard* is defined as the potential for harm, or adverse effect on an employee's health. Anything which may cause injury or ill health to anyone at or near a workplace is a hazard.
- *Risk* likelihood that a hazard will cause injury or ill health to anyone at or near a workplace is called risk. The level of risk increases with the severity of the hazard and the duration and frequency of exposure.
- *Exposure* occurs when a person comes into contact with a hazard.

Classes of Hazard

Hazards are classified into five different types. They are:

1. **Physical hazards** - includes floors, stairs, work platforms, steps, ladders, fire, falling objects, slippery surfaces, manual handling (lifting, pushing, pulling), excessively loud and prolonged noise, vibration, heat and cold, radiation, poor lighting, ventilation, air quality
2. **Mechanical and/or electrical hazards** - includes electricity, machinery, equipment, pressure vessels, dangerous goods, fork lifts, cranes, hoists
3. **Chemical hazards** - includes chemical substances such as acids or poisons and those that could lead to fire or explosion, like pesticides, herbicides, cleaning agents, dusts and fumes from various processes such as welding
4. **Biological hazards** - includes bacteria, viruses, mold, mildew, insects, vermin, animals
5. **Psychosocial environment hazards** - includes workplace stressors arising from a variety of sources.

Farm emergency procedures regarding safety working environment

1. Identify the potential emergencies.

The emergencies that may occur on a crop production farm could include:

- a. fire
 - b. Flood
 - c. typhoon,
 - d. machinery entrapment
 - e. electrical shock,
 - f. snake or spider bite
 - g. chemical exposure,
 - h. injuries,
 - i. illness and
 - j. accidents.
2. Provide emergency facilities appropriate for the sorts of emergencies that might occur on the farm (e.g. deluge showers, eye washes, firefighting equipment, first aid kits).
 3. Make sure that the correct equipment is available to contain and handle any chemical or other dangerous materials spills that might happen.
 4. To help minimize the risk of personal injury or property damage in the event of an emergency, people working on and visiting the farm need to know and understand the emergency procedures and their responsibilities.
 5. Instruct everyone working on the farm in the emergency response procedures
 6. Everyone should know the location of fire alarms, fire extinguishers and first aid kits; how and where to contact emergency services; and where to safely assemble in the event of an emergency.

The following factors may increase risk of injury or illness for farm workers:

1. **Age** – Injury rates are highest among children age 15 and under and adults over 65.
2. **Equipment and Machinery** – Most farm accidents and fatalities involve machinery. Proper machine guarding and doing equipment maintenance according to manufacturers' recommendations can help prevent accidents.



How Much Have You Learned?

Self-Check 1.1

IDENTIFICATION

1. _____ is the potential for harm, or adverse effect on an employee's health. Anything which may cause injury or ill health to anyone at or near a workplace is a hazard.
2. _____ is the likelihood that a hazard will cause injury or ill health to anyone at or near a workplace. The level of risk increases with the severity of the hazard and the duration and frequency of exposure.
3. _____ occurs when a person comes into contact with a hazard.
4. _____ hazards include floors, stairs, work platforms, steps, ladders, fire, falling objects, slippery surfaces, manual handling (lifting, pushing, pulling), excessively loud and prolonged noise, vibration, heat and cold, radiation, poor lighting, ventilation, air quality
5. _____ hazards include electricity, machinery, equipment, pressure vessels, dangerous goods, fork lifts, cranes, hoists
6. _____ hazards include chemical substances such as acids or poisons and those that could lead to fire or explosion, like pesticides, herbicides, cleaning agents, dusts and fumes from various processes such as welding
7. _____ hazards include bacteria, viruses, mold, mildew, insects, vermin, animals
8. _____ hazards include workplace stressors arising from a variety of sources.
9. _____ the physical or environmental conditions of work which comply with the prescribed Occupational Health Safety (OHS) standards and which allow the workers to perform his or her job without or within acceptable exposure to hazards.
10. _____ the practices related to production and work process

Refer to the Answer Key. What is your score?



What Do You Need To Know?

Read the Information Sheet 1.2 Find out much you can remember, and how much you learned by doing Self-check 1.2.

Information Sheet 1.2

FARM WORK THAT INVOLVE USING CHEMICALS AND HAZARDOUS TOOLS AND EQUIPMENT

1. Spraying Chemicals

Many different chemicals are used on a farm including pesticides. These chemicals are used to fertilize and control pests such as insects, weeds, mollusk, etc. Most of these chemicals are applied by spraying

Examples of chemical hazards:

- A. Spraying in a strong wind and the spray drifting over a dam or the farm house.
- B. Washing spray equipment and the water running into open drains, collecting in puddles, or running into stockyards or dams.
- C. Containers or chemicals left lying around. Empty containers lying in a heap.

Some ways you can reduce the risk of hazards from chemicals are:

- A. Use personal protective equipment such as respirators, waterproof clothes, rubber gloves, and waterproof footwear.
- B. Make sure chemicals are safely stored and cupboards locked.
- C. Never spray chemicals on days when there is a high wind.
- D. Know first aid procedures.
- E. Keep a list of all hazardous substances used on the farm.

Safe use of chemicals

- A. Consider if a chemical substance is really needed.
- B. Eliminate a hazardous substance, or if that is not possible, substitute it with less hazardous one.
- C. Safe work practices or personal protective equipment should be used.
- D. Keep records of farm chemicals.

2. Land Preparation Using Tractor

- A. Victim fall off or are thrown from the tractor.
- B. Run over by either the tractor or an implement being towed, or both.
- C. Over turning tracks

Safety Reminders

- A. Tractors are not passenger vehicles.
- B. Use seat belts when driving tractors.
- C. ROPS will protect the operator from serious injuries.

Causes of run over accidents

- C. Sudden stops
- D. Driving over holes, stumps and debris, or a sharp turn

How to prevent runaway

- A. Never allow riders on tractors.
- B. Discuss with family members and farm workers the potential risks of riding a tractor.
- C. It's also helpful to post 'no riders' decals on all tractors to remind others about the policy.
- D. Use or provide other vehicles that allow passengers, such as trucks or cars, when transportation is needed to fields or remote work sites.

3. Cutting Trees Using Chainsaws

A chainsaw makes light work of felling and cutting up trees but treat it with respect!-. A chainsaw can easily slice through muscle or bone if it kicks back towards you. It is essential to get training from a qualified person before you use a chainsaw.

Examples of chainsaw hazards:

- A. Chainsaw kickback, caused when the upper part of the bar nose contacts a solid object or is pinched. This can throw the guide bar back towards you and can cause serious injury.
- B. Using a small saw and bar to fell a big tree.
- C. Felling large shelterbelt trees, or trees with a heavy lean or on steep slopes.
- D. Felling trees with stem rot or a species prone to splitting.

Some ways you can reduce the risk of hazards from chainsaws are:

- A. Know your saw and how to use the safety devices.
- B. Wear and use the correct personal safety equipment. You need:
 - FOOTWEAR - boots with steel toe caps.
 - LEG PROTECTION - chainsaw operator's safety trousers or chaps.
 - SAFETY HELMET.
 - EARMUFFS rated Grade 4
 - EYE PROTECTION - goggles in dusty conditions or a helmet visor if there's a danger of flying debris.
- C. Check the work area for hazards such as branches or tree tops that could fall.
- D. Check that your saw is in good order and is adjusted to the manufacturer's specifications.
- E. Do not over-reach or cut above shoulder height

Personal Protective Equipment (PPE)

Personal protective equipment (PPE) can reduce the number and severity of farm work related injuries and illnesses. Personal protective equipment not only helps protect people but also improves productivity and profits. Farmers and ranchers can share in these benefits by using the appropriate protective equipment for themselves, family members and employees, when the job and its potential hazards call for it.



- Protect your head with a hard hat when performing construction work, trimming trees, repairing machinery, and doing other jobs with head injury risks.

- Use a sun safety hat (one with a wide brim and neck protection) to save skin cancer.



- Protect your vision with appropriate safety eyewear (safety glasses, goggles, face-shields) when applying pesticides, fertilizers, working in the shop, or in heavy dust conditions.



- Protect your hearing with acoustic earmuffs or plugs when operating noisy equipment such as grain dryers, feed grinders, older tractors, chain saws, etc.



- Protect your lungs with the correct respiratory equipment (dust masks, cartridge respirators, gas masks, air packs) when working in dusty or moldy conditions, spray painting, applying chemicals, working in bins, tanks, silos, and manure storage places.



How Much Have You Learned?

Self-Check 1.2

Fill-in the blanks:

1. _____ can reduce the number and severity of farm work related injuries and illnesses.
- 2-4 Protect your head with a hard hat when performing 2._____, 3._____,4._____, with head injury risks.
1. Use a sun safety hat (one with a wide brim and neck protection) to assist in the prevention of 5._____.
- 6-8 Protect your vision with appropriate safety eyewear (6._____, 7_____, 8._____) when applying pesticides, fertilizers, working in the shop, or in heavy dust conditions
- 9-10 Protect your hearing with acoustic earmuffs or plugs when operating noisy equipment such as 9._____, 10._____, older tractors, chain saws, etc.



How Do You Apply What You Learned?

Show that you learned something by doing this activity

Operation Sheet 1.1

Conduct Hazard Report

MATERIALS NEEDED:

Quantity	Description
2 sheets	Bond paper short
1 pc	Pencil/Ballpen

INSTRUCTIONS:

1. Visit farm near your school or home.
2. Observe the surroundings.
3. List all the possible hazard.
4. Classify these hazards that can occur
5. Identify persons who are at risk with these hazards.
6. Suggest possible solution to reduce or eliminate the risks.
7. Report your findings to your teacher.

Demonstrating proper wearing of PPE

MATERIALS NEEDED:

Quantity	Description
1 pc	Hard hat
1 pc	Facemask
1 pc	Footwear
1 pc	Goggles
1 pc	Earmuffs
2 sheets	Bond paper
1 pc	1 pencil or ballpen

INSTRUCTIONS:

1. PPE will be prepared by your teacher ahead of this activity.
2. Identify the necessary PPE for specific farm activities.
3. Demonstrate the farm activities given by your teacher through action or body language.
4. After the specific farm activities, take off PPE from your body, and write the reasons why you wear that particular PPE when performing that task.



How Well Did You Perform?

**Find out by accomplishing the Scoring Rubric honestly and sincerely.
Remember it is your learning at stake!**

For Activity 1.1

Criteria	Score			
	20	15	10	5
Potential hazard are properly identified				
Report is properly made				
Suggestions are made to reduce the risk				
Potential victims are properly identified				

For Activity

Criteria	Score			
	20	15	10	5
Identification and selection of correct PPE				
Reenactment of farm activities				
A written report				

Interpretation of Scores:

16 – 20 – Excellent output

11 – 15 – Very good

6 – 10 – Fair output

5 and below – Poor output

LEARNING OUTCOME 2

- **Safekeep/dispose tools, materials and outfit**

PERFORMANCE STANDARDS

- Used tools and outfit are cleaned and stored in line with farm procedure.
- Unused materials are labeled and stored according to manufacturers' recommendation and farm requirements.
- Waste materials are disposed according to manufacturers, government and farm requirements.



Materials

- Cleaning tools and supplies
- PPE
- References



What Do You Already Know?

Let us determine how much you already know about safekeeping/disposing tools, materials and outfit. Take this test.

Pretest LO 2

Enumerate the following:

(2) Tips on cleaning equipments, tools and garbage cans:

(2) Tips on cleaning areas for handling and storing fresh produce:

(2) Tips on cleaning hygienic facilities:

(4) ENVIRONMENTAL LAWS



What Do You Need To Know?

Read the Information Sheet 2.1 Find out how much you can remember and how much you have learned by doing Self-check 2.1.

Information Sheet 2.1

Cleaning, Storing and Waste Management

Protect Tools From the Elements

Blades such as electric hedge trimmer blades, hoes, shovels, and other metal surfaces can be sprayed with lubricant oil. Spray the blades then turn them on to make sure oil works into all areas. All electrical and petrol gardening equipment will need to be covered with a blanket or sheet if kept in the shed. This will prevent dust and dirt getting to them.

General cleaning procedures:

The farmer and/or farm workers responsible for cleaning must adhere as much as possible to the following procedures:

- Be properly trained on the cleaning procedures.
- Develop a cleaning program and schedule according to the recommended frequency and the cleaning program should be monitored to ensure its effectiveness.
- Cleaning must not take place while fresh vegetables are being harvested, packed, handled, and stored.
- Water that is used for cleaning must be safe.
- The cleaning of equipment, tools, and containers must take place in a designated area away from field and the storage of agricultural inputs and fresh vegetables.
- When using cleaning and disinfection chemicals, the farmer and/or farm workers must become familiar with the instruction use of these products.

- Strictly adhere to all precautionary statements and mixing instructions.
- Protect equipment's, tools, containers and fresh vegetables when working with any chemicals.

Cleaning re-usable containers:

The farmer and/or farm workers responsible for cleaning re-usable containers must adhere as much as possible to the following procedures:

- Remove as much as possible plant debris, soil, and residues of any kind, use a brush or appropriate tool whenever necessary.
- Inspect containers for physical damage that might injure, spoil, and contaminate fresh vegetables, if found, repair them.
- Inspect containers for any missed plant debris, soil and residues, if found, re-clean.
- If cleaning and/or disinfection chemicals are used, follow label instructions for mixing.
- Rinse containers with clean water.
- Whenever possible, place them in the sun for rapid drying.
- Store re-usable containers properly to avoid contamination.

Cleaning equipments, tools and garbage cans:

The farmer and/or farm workers responsible for cleaning the equipment (e.g. tables, racks, plastic sheet, etc.), tools (e.g. secateurs, knives, brushes, etc.) and garbage cans must adhere as much as possible to the following procedures:

- Remove as much as possible plant debris, soil, and residues of any kind. Use a brush or another appropriate tool when necessary.
- Inspect equipment for physical damage which might injure, spoil and contaminate fresh vegetables.
- Inspect equipments, tools, and garbage cans for any missed plant debris, soil, and residues, if found, clean again.
- If cleaning and/or disinfection chemicals are used, follow label instructions for mixing.
- As required, apply cleaning materials such as detergent and/or disinfection chemicals, and ensure that no spots are missed.
- Rinse with safe water, if there are parts of the equipment that cannot be rinsed with water, use a clean wet towel and follow the same procedures for cleaning.
- Ensure that small equipments and tools do not touch the ground floor after the cleaning procedures.
- When possible, place in the full sun for rapid drying.
- Store equipment and tools properly to avoid contamination.

Cleaning areas for handling and storing fresh produce:

The farmer and farm workers responsible for cleaning these areas must adhere as much as possible to the following procedures:

- Unplug any electrical equipment and if possible, cover with plastic electrical motors, electrical boxes, connections, light fixtures, etc. Do not use packaging materials for this task.
- Remove trash and any accumulated plant debris from the floors.
- Using low pressure water, rinse the entire ceiling and light fixtures to remove any dust

and soil build up.

Rinse walls, windows and doors from the top downward.

Rinse the entire floor surface to remove any soil build up. Be careful not to splash water onto equipment.

- If necessary, scrub areas with brush and cleaning materials such as detergent, and ensure that no spots are missed.
- After scrubbing areas with cleaning materials, rinse surface areas as described previously wash out drains; be careful not to splash water onto equipment.
- If cleaning and/or disinfection chemicals are used, follow label instructions for mixing.

Cleaning hygienic facilities:

The farmer and/or farm workers responsible for cleaning hygienic facilities must adhere as much as possible to the following procedures:

- Pick up trash from the floors, and in a trash can.
- By using proper detergents, clean toilets, sinks, and any other fixtures.
- Using low pressure water, rinse the entire floor surface to remove any soil build up.
- If cleaning and/or disinfection chemicals are used, follow label instructions for mixing.
- As required, apply cleaning materials or disinfection chemicals to entire floor surface area, scrub areas with brush if needed, and ensure that no spots are missed.
- Rinse floor and drains.
- Remove excess water and allow drying out at room temperature.
- Ensure that hygienic facilities have enough toilet paper, soap, and disposable towel.

Technique in storing chemicals

Chemicals are used on farms for a variety of purposes. The safe management of chemicals requires access to information and responsible action. Manufacturers, suppliers, and users of farm chemicals all have a important role to play. Chemical substances present different types of risks to people's health, safety, and the environment. For this reason there are different laws controlling them. The purpose of these laws is to ensure that chemicals are used safely and efficiently so that risks to human health, the environment and damage to property are minimized.

Safe Management of chemicals involves:

- correct labeling and packaging;
- provision of material safety data sheets (MSDS);
- safe transport, storage, use, and disposal of substances.

Labeling and Packaging of Chemicals

Chemicals must be supplied in packages that are correctly labeled and suitable for the substance. Information provided on the label will depend on the type of substance and the risks associated with it. Items to look for are:

1. Signal words such as 'CAUTION', 'POISON' or 'DANGEROUS POISON', used for scheduled poisons – a signal word alerts users to the possibility of poisoning if the substance is swallowed, inhaled or absorbed through the skin.
2. The Dangerous Goods (ADG) diamond, if there is an immediate risk to health or safety e.g. flammable liquids.
3. Risk phrases describing the type of health effects e.g. 'irritating the skin', and safety phrases stating precautions for safe handling, storage, spills, disposal and fire e.g. 'keep away from combustible material'

Ensure that containers remain labeled

Farmers must ensure that the original labels remain on containers of substances. If a substance is poured into a second container such as a spray tank then that container must be labeled with the product name and appropriate risk and safety phrases. These can generally be copied from the parent container. Labeling is not necessary if a substance is used immediately and its container is thoroughly cleaned.

There are good reasons for ensuring that proper containers and appropriate labels are used, including:

- Using food containers to store poisons can result in poisoning due to accidental swallowing.
- Insurance companies may question liability if something goes wrong and an unlabeled container has been the cause of an incident.
- Produce cannot be exported if maximum residue limits are exceeded labels provide advice on permitted use and withholding periods for agricultural and veterinary chemicals.

Material Safety Data Sheets

Material safety data sheets (MSDS) must be produced by the manufacturer or importer of hazardous substance.

The MSDS is not just a piece of paper. It provides important and useful advice about what is in the product, its health effects, safe use and handling, storage, disposal, first aid and emergency operation. Farmers must obtain the MSDS from their supplier and keep them in a register where they are available to people who could be exposed to the hazardous substance.

The register is a collection of the MSDS and other information which can be kept in a folder, filing cabinet or other practical system.

The register can be kept in the house, workplace or the chemical store, as long as it remains accessible to emergency service personnel and any employees who may be exposed to hazardous substances.

Storage and Transport of Chemicals

Safe storage of farm chemicals is needed to protect them from the elements, restrict access to them, prevent contamination of the environment, food, or livestock, and ensure separation from other incompatible chemicals. Arrangements must be in place to contain any spillage of the chemical.

After considering the potential risk to people's health or to the environment, a farmer might decide that a locked shed with a roof and concrete floor, which is bounded to contain any spills, is the best way to provide safe storage.

Remember, you should never store oxidizing agents with fuels. That is – never store substances labeled with a yellow diamond and with a red diamond.

Safe transport of farm chemicals depends on what the substance is, how much there is, where it is to be transported, and what else is to be transported with it. In general, small quantities (less than 250 liters) can be transported on vehicle provided that the container is properly secured and safe from spillage.

Disposal of Farm Chemicals

Empty farm chemical containers and unwanted chemicals need to be disposed of properly. Prior to disposal of empty containers, wash the container out three times and use the rinse water to dilute further batches of the chemical to working strength.

To wash a container, you do not need to fill it each time. If you only have six liters of water, it is more efficient to use three washes of two liters each, than it is to rinse once with the full six liters.

ENVIRONMENTAL LAWS

Presidential Decree (PD) 1152, “the Philippine Environmental Code,” which took effect in 1977, provides a basis for an integrated waste management regulation starting from waste source to methods of disposal. PD 1152 has further mandated specific guidelines to manage municipal wastes (solid and liquid), sanitary landfill and incineration, and disposal sites in the Philippines. In 1990, the Philippine Congress enacted the Toxic Substances, Hazardous and Nuclear Wastes Control Act, commonly known as Republic Act (RA) 6969, a law designed to respond to increasing problems associated with toxic chemicals and hazardous and nuclear wastes. RA 6969 mandates control and management of import, manufacture, process, distribution, use, transport, treatment, and disposal of toxic substances and hazardous and nuclear wastes in the country. The Act seeks to protect public health and the environment from unreasonable risks posed by these substances in the Philippines. Apart from the basic policy rules and regulations of RA 6969, hazardous waste management must also comply with the requirements of other specific environmental laws, such as PD 984 (Pollution Control Law), PD 1586 (Environmental Impact Assessment System Law), RA 8749 (Clean Air Act) and RA 9003 (Ecological Solid Waste Management Act) and their implementing rules and regulations.



How Much Have You Learned?

Self-Check 2.1

- (2) Tips in cleaning equipment, tools, and garbage cans;
- (2) Tips in cleaning areas for handling and storing fresh produce;
- (2) Tips in cleaning hygienic facilities;
- (4) ENVIRONMENTAL LAWS

Refer to the Answer Key. What is your score?



How Do You Apply What You Learned?

Show that you learned something by doing this activity

Activity Sheet 2.1

Make a Poster on Proper Waste Disposal

MATERIALS NEEDED:

Quantity	Description
1 pc	White cartolina
1 pc	Pencil
1 pc	Ruler
1 set	Crayon

INSTRUCTIONS:

1. Prepare the needed materials.
2. You learned on the information sheet 2.1 the proper way of disposing waste and the government laws regarding this. Imagine you are a farmer and you need to dispose your farm waste, what will you do?
3. Illustrate or draw your answer to the problems given.
4. Submit your work to your teacher after one day for evaluation.

Slogan Making Contest

MATERIALS NEEDED:

Quantity	Description
2 sheets	Bond paper
1 pc	Pentel pen/ Marker

INSTRUCTIONS:

1. Prepare the needed materials.
2. Think of a slogan on the proper use of tools and equipment.
3. The slogan may be express using local dialect.
4. You will be given 20 minutes to prepare your slogan.
5. Submit your output when it is already complete
6. The teacher will select the best slogan and will receive additional points for this activity



How Well Did You Perform?

Find out by accomplishing the Scoring Rubric honestly and sincerely.
Remember it is your learning at stake!

For Activity 2.1

Criteria	Score			
	20	15	10	5
Content and Message 70%				
Creativity 20%				
Neatness 10 %				

For Activity 2.2

Criteria	Score			
	20	15	10	5
Relevance 60%				
Rhyme 20%				
Presentation 10%				
Neatness 10 %				

Interpretation of Scores:

- 16 – 20 – Excellent output
- 11 – 15 – Very good
- 6 – 10 – Fair output
- 5 and below – Poor output

Congratulations! You did a great job!



REFERENCES

LO1

- CBLM Horticulture
- <http://www.safework.sa.gov.au/contentPages/docs/empFarmChemicals.pdf>
- http://www.necasag.org/pdf/Personal_protective_equipment_updated.pdf
- http://www.ashinstitute.org/PDFS/ASHI_BasicFirstAid_SG_Sample.pdf
- <http://firstaid.about.com/od/cpr/ss/abcs.htm>
- <http://www.ci.miami.fl.us/Fire/DEM/pages/SafetyTips/BASIC%20FIRST%20AID%20PROCEDURES.pdf>
- <http://www.extension.iastate.edu/publications/PM1563K.pdf>
- <http://www.public-health.uiowa.edu/icash/resources/Basic-Farm-First-Aid-Kit-List.pdf>
- http://hostedmedia.reimanpub.com/TFH/Step-By-Step/display/FH00MAR_SHARPT_06.JPG
- http://www.thucphamantoanviet.vn/a-aproducers-and-traders/a-egetables-fruits-tea/a-quality-assurance-systems/1200_-_ffv_-_gap_-_sop_for_cleaning equipments_tools_containers_handling_and_storage_areas_for_fresh_vegetables_-_version_3.0.pdf
- <http://www.dardn>
- <http://www.emb.gov.ph/LO2>

LO 2

- Horticulture CBLM
- http://hostedmedia.reimanpub.com/TFH/Step-By-Step/display/FH00MAR_SHARPT_06.JPGhttp://www.thucphamantoanviet.vn/a-aproducers-and-traders/a-egetables-fruits-tea/a-quality-assurance-systems/1200_-_ffv_-_gap_-_sop_for_cleaning equipments_tools_containers_handling_and_storage_areas_for_fresh_vegetables_-_version_3.0.pdf
- <http://www.dardn>

ANSWER KEYS

LESSON 1: USE FARM TOOLS AND EQUIPMENT	
<p>ANSWER KEY (PRE-TEST LO1)</p> <p>1.b 2.b 3.d 4.d 5.a 6.b 7.b 8.b 9.d 10.a</p>	<p>ANSWER KEY (SELF CHECK #1.1)</p> <p>1. C 2. D 3. I 4. J 5. E 6. F 7. H 8. A 9. B 10. G</p>
<p>ANSWER KEY (PRE-TEST LO2)</p> <p>1. These are machineries used in horticultural operations especially in vegetable production. They are used in land preparation and in transporting farm inputs and products. These equipment need a highly skilled operator to use.</p> <p>2. Answer: A. Hand tractor is used to pull a plow and harrow in preparing a large area of land. B. Four wheel tractor is used to pull a disc plow and disc harrow in preparing much bigger area of land. C. Water pumps are used to draw irrigation water from a source.</p>	<p>ANSWER KEY (SELF-CHECK # 2.1)</p> <p>1. These are machineries used in horticultural operations especially in vegetable production. They are used in land preparation and in transporting farm inputs and products. These equipment need a highly skilled operator to use</p> <p>2. Answer: A. A hand tractor is used to pull a plow and harrow in preparing a large area of land. B. A four wheel tractor is used to pull a disc plow and disc harrow in preparing much bigger area of land C. Water pumps are used to draw irrigation water from a source</p>
<p>ANSWER KEY (PRE-TEST LO3)</p> <p>1. False 2. True 3. True 4. True 5. True 6. True 7. True 8. False 9. True 10. True</p>	<p>ANSWER KEY (SELF CHECK # 3.1)</p> <p>1. TRUE 2. TRUE 3. TRUE 4. TRUE 5. TRUE 6. TRUE 7. TRUE 8. TRUE 9. TRUE 10. TRUE</p>

LESSON 2: PERFORM ESTIMATION AND BASIC CALCULATION**ANSWER KEY (PRE-TEST LO1)**

1. Seeds
2. Fertilizer
3. Seedlings
4. Plowing using animal
5. Plowing using tractor
6. Harrowing using hand tractor
7. Mulching
8. Digging
9. Fertilizer application
10. Transplanting

ANSWER KEY SELF-CHECK 1.1

1. Seeds
2. Fertilizer
3. Insecticides or Pesticides
4. Clearing of the land
5. Plowing
6. Harrowing
7. Mulching
8. Irrigation
9. Weeding
10. Harvesting

ANSWER KEY (PRE-TEST LO2)**CONVERSION**

1. 100 cm
2. 4m
3. 5000 m
4. 100,000cm
5. 2 km

AREA

1. 36 ha
2. 10 ha
3. 6 ha
4. 12 ha
5. 30 ha

PERCENTAGE

1. 6 plants
2. 4.2ha
3. 72farmers
4. 100pesos
5. 5seeds

ANSWER KEY (PRE-TEST LO2)**CONVERSION**

6. 100 cm
7. 4m
8. 5000 m
9. 100,000cm
10. 2 km

AREA

6. 36 ha
7. 10 ha
8. 6 ha
9. 12 ha
10. 30 ha

PERCENTAGE

6. 6 plants
7. 4.2ha
8. 72farmers
9. 100pesos
10. 5seeds

LESSON 3: INTERPRET PLANS AND DRAWINGS

ANSWER KEY (PRE-TEST LO1)

1. 42 sq.m
2. 6 rows
3. 5 plants
4. 30 plants
5. 1 meter
6. 1 meter
7. 5 plants
8. 7 m
9. 6 m
10. 15 plants

ANSWER KEY (SELF-CHECK 1.1)

1. False
2. True
3. True
4. True
5. False
6. True
7. True
8. True
9. True
10. False

ANSWER KEY (SELF-CHECK 1.2)

A. Square system

Advantages

1. Irrigation channels and paths can be made straight.
2. Operations like ploughing, harrowing, cultivation, spraying and harvesting becomes easy.
3. Better supervision of the orchard is possible as one gets a view of the orchard from one end to the other.

Disadvantages

1. Comparatively less number of trees is accommodated in given area.
2. Distance between plant to plant and row to row remains the same and, hence, a certain amount of space in the middle of four trees is wasted.

B. Rectangular system

Advantages

1. Intercultural operations can be carried out easily.
2. Irrigation channel can be made length and breadth wise
3. Light can penetrate into the orchard through the large inter spaces between rows.
4. Better supervision is possible.
5. Intercropping is possible.

Disadvantages

1. A large area of the orchard between rows is wasted if intercropping is not practiced.
2. Less number of trees are planted.

C. Quincunx or Diagonal system

Advantages

1. Additional income can be earned from the

filler crop till the main crop comes into bearing.
2. Compared to square to square and rectangular systems, almost double the number of trees can be planted initially.
3. Maximum utilization of the land is possible.

Disadvantages

1. Skill is required to layout the orchard.
2. Inter/filler crop can interfere with the growth of the main crop.
3. Intercultural operations become difficult.
4. Spacing of the main crop is reduced if the filler crop is allowed to continue after the growth of the main crop

D. Hexagonal system

Advantages

1. Compared to square system 15% more trees can be planted.
2. It is an ideal system for the fertile and well irrigated land.
3. Plant to plant distance can be maintained the same.
4. More income can be obtained.

Disadvantages

1. Intercultural operations become difficult.
2. Skill is required to layout the orchard.

E. Contour system

Advantages

1. This system can be adopted in hilly regions and in leveled land.
2. Contour system can control the soil erosion.
3. It helps simultaneously in the conservation of water.
4. Preservation of plant nutrients supplied by manures and fertilizers possible.
5. Contours form an easy path for movements on the hill slopes for carrying out various orchard operations such as weeding, manuring, pruning, harvesting, disease and pest control.

Disadvantages

1. Laying out of contour lines is difficult and time consuming.
2. Special skill is required to layout this system.
3. Special instruments are required for making contour lines.
4. The row to row distance will not be equal and adjustments may be required in the plant to plant distance.
5. Rows are broken in to bits and pieces.

<p>ANSWER KEY (PRE-TEST LO2)</p> <p>FUNCTIONS OF FARM IRRIGATION SYSTEMS</p> <ol style="list-style-type: none"> 1. Diverting water from the water source. 2. Conveying it to individual fields within the farm. 3. Distributing it within each field. 4. Providing a means for measuring and regulating flows. <p>ESSENTIAL FEATURES OF A PLAN</p> <ol style="list-style-type: none"> 1. Topographic Data 2. Water Source Capacity 3. Depending on the water source, a well log or water license must accompany the irrigation plan. 4 Soil and Crop Characteristics 5. Design Parameters 6. Design Data 	<p>ANSWER KEY (2.1)</p> <p>(4)FUNCTIONS OF FARM IRRIGATION SYSTEMS</p> <ol style="list-style-type: none"> 1. Diverting water from the water source. 2. Conveying it to individual fields within the farm. 3. Distributing it within each field. 4. Providing a means for measuring and regulating flows. <p>(6)ESSENTIAL FEATURES OF A PLAN</p> <ol style="list-style-type: none"> 1. Topographic Data 2. Water Source Capacity 3. Depending on the water source, a well log or water license must accompany the irrigation plan. 4 Soil and Crop Characteristics 5. Design Parameters 6. Design Data
<p>TYPES OF CONVENTIONAL SPRINKLER SYSTEMS</p> <ol style="list-style-type: none"> 1. Fully portable system 2. Semi-portable system 3. Fully permanent system <p>Advantages of drip or trickle irrigation</p> <ol style="list-style-type: none"> 1. Water is applied directly to the crop ie. entire field is not watered. 2. Water is conserved. 3. Weeds are controlled because only the places getting water can grow weeds. 4. There is a low pressure system. 5. There is a slow rate of water application somewhat matching the consumptive use. Application rate can be as low as 1 - 12 l/hr. 6. There is reduced evaporation, only potential transpiration is considered. 7. There is no need for a drainage system. 	<p>ANSWER KEY 2.2</p> <p>(3) Types of Conventional Sprinkler Systems</p> <ol style="list-style-type: none"> 1. Fully portable system 2. Semi-portable system 3. Fully permanent system <p>(8) Advantages of drip or trickle irrigation</p> <ol style="list-style-type: none"> 1. Water is applied directly to the crop ie. entire field is not wetted. 2. Water is conserved 3. Weeds are controlled because only the places getting water can grow weeds. 4. There is a low pressure system. 5. There is a slow rate of water application somewhat matching the consumptive use. Application rate can be as low as 1 - 12 l/hr. 6. There is reduced evaporation, only potential transpiration is considered. 7. There is no need for a drainage system.

LESSON 4: APPLYING SAFETY MEASURES IN FARM OPERATIONS

ANSWER KEY (PRE-TEST LO1)

1. D
2. A
3. B
4. D
5. A
6. A
7. A
8. A
9. A
10. A

ANSWER KEY (SELF-CHECK 1.1)

1. Personal protective equipment (PPE)
2. construction work
3. Trimming trees
4. Repairing machinery
5. Skin cancer
6. Safety glasses
7. Goggles
8. Face-shields)
9. Grain dryers
10. Feed grinder

ANSWER KEY (PRE-TEST LO2) & (SELF-CHECK.2.1)

Tips in cleaning equipment, tools and garbage cans:

- Remove as much as possible plant debris, soil and residues of any kind, use a brush or another appropriate tool when necessary.
- Inspect equipments for physical damage which might injure, spoil and contaminate fresh vegetables, if found, repair them.
- Inspect equipments, tools and garbage cans for any missed plant debris, soil and residues, if found, clean again.
- If cleaning and/or disinfection chemicals are used, follow label instructions for mixing.
- As required, apply cleaning materials such as detergent and/or disinfection chemicals, and ensure that no spots are missed.
- Rinse with safe water, if there are parts of the equipment that cannot be rinsed with water, use a clean wet towel and follow the same procedures for cleaning.
- Ensure that small equipments and tools do not touch the ground floor after the cleaning procedures.
- When possible place in the full sun for rapid drying.
- Store equipment's and tools properly to avoid contamination.

Tips in cleaning areas for handling and storing fresh produce:

- Unplug any electrical equipment's and if possible, cover with plastic electrical motors, electrical boxes, connections, light fixtures, etc. do not use packaging materials for this task.
- Remove trash and any accumulated plant debris from the floors.
- Using low pressure water for, Rinse the entire ceiling infrastructure and light fixtures

- to remove any dust and soil build up.
Rinse walls, windows and doors from the top downward
Rinse the entire floor surface to remove any soil build up, be careful of not splashing water onto equipment's.
- If necessary, scrub areas with brush and cleaning materials such as detergent, and ensure that no spots are missed.
 - After scrubbing areas with cleaning materials, rinse surface areas as described previously wash out drains; be careful of not splashing water onto equipment's.
 - If cleaning and/or disinfection chemicals are used, follow label instructions for mixing.
- Tips in cleaning hygienic facilities:*
- Pick up trash from the floors and remove to trash can.
 - By using the proper detergent, clean toilets, sinks and any other fixtures.
 - Using low pressure water, rinse the entire floor surface to remove any soil build up.
 - If cleaning and/or disinfection chemicals are used, follow label instructions for mixing.
 - As required, apply cleaning materials or disinfection chemicals to entire floor surface area, scrub areas with brush if needed, and ensure that no spots are missed.
 - Rinse floor and drains.
 - Remove excess water and allow drying out at room temperature.
 - Ensure that hygienic facilities have enough toilet paper, soap and disposable towel.

ENVIRONMENTAL LAWS

- Presidential Decree (PD) 1152,
- "the Philippine Environmental Code," which took effect in 1977, provides a basis for an integrated waste management regulation starting from waste source to methods of disposal.
- PD 1152 has further mandated specific guidelines to manage municipal wastes (solid and liquid), sanitary landfill and incineration, and disposal sites in the Philippines.
- Republic Act (RA) 6969
- PD 984 (Pollution Control Law),
- PD 1586 (Environmental Impact Assessment System Law),
- RA 8749 (Clean Air Act) and
- RA 9003 (Ecological Solid Waste Management Act) and their implementing rules and regulations.

Acknowledgement

This Learning Module was developed for the Exploratory Courses in Technology and Livelihood Education, Grades 7 of the K to 12 Curriculum with the assistance of the following persons:

This Learning Module on **Horticulture NC II** was developed by the following personnel:

MODULE WRITER

VICTOR V. INTACTO III

Balagtas National Agricultural High School

REVIEWERS

GIL P. CASUGA

Chief TESD Specialist

REYNALDO S. DANTES

Senior TESD Specialist

BERNADETTE S. AUDIJE

Senior TESD Specialist

PARALUMAN R. GIRON, Ed.D.

Chair, Sub-TWG on K to 10

OFELIA O. FLOJO

Retired Assistant Chief, EED, Region IV-A

AIDA T. GALURA

VSA II, ACNTS

MARIA A. ROQUE

Senior TESD Specialist

VICTORIO N. MEDRANO

Principal IV, SPRCNHS

BRENDA B. CORPUZ, Ph.D.

TA for K to 12 Curriculum

BEATRIZ A. ADRIANO

Principal IV, ERVHS

DOMINGA CAROLINA F. CHAVEZ

Principal II, MBHS

DOCUMENTORS / SECRETARIAT

PRISCILLA E. ONG

K to 12 Secretariat

EMMANUEL V. DIONISIO

Head Teacher III, AFGBMTS

DANTE D. VERMON JR.

Teacher I, AFGBMTS

FREDERICK G. DEL ROSARIO

Head Teacher III, BNAHS

LYMWEL P. LOPEZ

Teacher I, AFGBMTS

JOANNA LISA C. CARPIO

Teacher I, BNAHS

Dir. IMELDA B. TAGANAS

*Executive Director, Qualifications Standards Office
K to 12 Learning Area Team Convenor, TLE/TVE*